

VERTICAL TURBINE FIRE PUMP | ACCESSORIES | SUBMITTAL

File No: F51.759
Date: JULY 22, 2013
Supersedes: F51.751
Date: AUGUST 15, 2005

Job: _____ Customer: _____
Item no.: _____ Order no.: _____
Mfg. Rep.: _____ Dwg. no.: _____ Serial no.: _____
Not to be used for construction unless certified: By: _____ Date: _____
Mfg.: Randolph Gear Model: _____

RIGHT ANGLE GEAR DRIVE - RANDOLPH



RIGHT ANGLE GEAR DRIVE

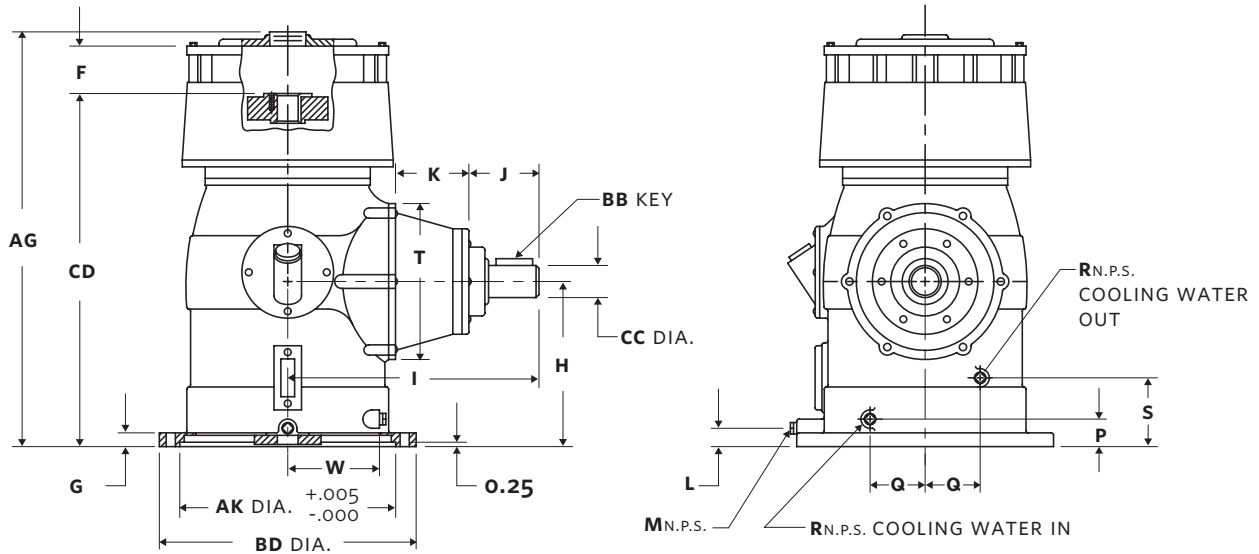

MODEL	M40/M60 M80/M100	G40/G60 G80	G100/G125 M150	M200	G150 G200A	G250 G300	G350 G400	G450	F500/ F590 F750	F1000	F1200 F1500
AG (FAN)	22 $\frac{1}{4}$	28 $\frac{11}{16}$	26 $\frac{11}{16}$	29 $\frac{15}{16}$	34	34	36	37	45 $\frac{7}{16}$	45- $\frac{7}{16}$	46- $\frac{1}{8}$
AJ	14 $\frac{3}{4}$	14 $\frac{3}{4}$	14 $\frac{3}{4}$	14 $\frac{3}{4}$	18- $\frac{1}{4}$	18- $\frac{1}{4}$	18 $\frac{3}{4}$	18 $\frac{3}{4}$	23	23	28 $\frac{3}{4}$
AK	13.501	13.501	13.501	13.501	13.501	13.501	13.501	13.501	13.501	13.501	22.005
BB	$\frac{3}{8} \times \frac{3}{16}$	$\frac{3}{8} \times \frac{3}{16}$	$\frac{5}{8} \times \frac{5}{16}$	$\frac{5}{8} \times \frac{5}{16}$	$\frac{5}{8} \times \frac{5}{16}$	$\frac{3}{4} \times \frac{3}{8}$	$\frac{3}{4} \times \frac{3}{8}$	$\frac{3}{4} \times \frac{3}{8}$	$\frac{7}{8} \times \frac{7}{16}$	$\frac{7}{8} \times \frac{7}{16}$	$\frac{7}{8} \times \frac{7}{16}$
BD	16 $\frac{1}{2}$	16 $\frac{1}{2}$	16 $\frac{1}{2}$	16 $\frac{1}{2}$	20	20	20	20	24 $\frac{1}{2}$	24 $\frac{1}{2}$	30 $\frac{1}{2}$
BF	$\frac{11}{16}$	$\frac{11}{16}$	$\frac{11}{16}$	$\frac{11}{16}$	$\frac{11}{16}$	$\frac{11}{16}$	$\frac{11}{16}$	$\frac{11}{16}$	$\frac{13}{16}$	$\frac{13}{16}$	$\frac{13}{16}$
BX MAX.	1 $\frac{1}{2}$	1 $\frac{1}{2}$	1 $\frac{1}{2}$	1 $\frac{15}{16}$	1- $\frac{15}{16}$	1 $\frac{15}{16}$	2- $\frac{3}{16}$	2 $\frac{3}{16}$	2 $\frac{15}{16}$	2 $\frac{15}{16}$	4 $\frac{1}{4}$
BX MIN.	$\frac{3}{4}$	$\frac{3}{4}$	$\frac{3}{4}$	1 $\frac{3}{16}$	1- $\frac{3}{16}$	1 $\frac{3}{16}$	1 $\frac{1}{2}$	1 $\frac{1}{2}$	1 $\frac{11}{16}$	1 $\frac{11}{16}$	2 $\frac{15}{16}$
C TAP	-	-	-	-	$\frac{5}{8}$ -11	$\frac{5}{8}$ -11	$\frac{5}{8}$ -11	$\frac{5}{8}$ -11	$\frac{5}{8}$ -11	$\frac{5}{8}$ -11	$\frac{3}{4}$ -10
CC	1.874	1.874	2.249	2.437	2.437	2.937	2.937	2.937	3.749	3.749	3.749
CD	17 $\frac{5}{8}$	22 $\frac{9}{16}$	22 $\frac{5}{8}$	24 $\frac{7}{8}$	29 $\frac{3}{16}$	29 $\frac{3}{16}$	31- $\frac{9}{16}$	32- $\frac{3}{4}$	40 $\frac{13}{16}$	40 $\frac{13}{16}$	37 $\frac{3}{4}$
DD	-	-	-	-	14- $\frac{3}{4}$	14- $\frac{3}{4}$	14 $\frac{3}{4}$	14 $\frac{3}{4}$	14 $\frac{3}{4}$	14 $\frac{3}{4}$	26
F (FAN)	3 $\frac{15}{16}$	3 $\frac{1}{2}$	3 $\frac{1}{2}$	4 $\frac{1}{2}$	4- $\frac{1}{8}$	4 $\frac{1}{16}$	3- $\frac{3}{8}$	3 $\frac{3}{8}$	3 $\frac{7}{8}$	3 $\frac{7}{8}$	7 $\frac{1}{2}$
G	$\frac{13}{16}$	$\frac{7}{8}$	$\frac{7}{8}$	$\frac{7}{8}$	$\frac{7}{8}$	$\frac{7}{8}$	$\frac{7}{8}$	$\frac{7}{8}$	1 $\frac{3}{4}$	1 $\frac{3}{4}$	1 $\frac{3}{4}$
H	8 $\frac{1}{2}$	11 $\frac{7}{16}$	11 $\frac{7}{16}$	11 $\frac{7}{16}$	13- $\frac{3}{4}$	13- $\frac{3}{4}$	13 $\frac{3}{4}$	13 $\frac{3}{4}$	18 $\frac{3}{4}$	18 $\frac{3}{4}$	16
I	17	18	18	18	20 $\frac{15}{16}$	21- $\frac{3}{4}$	21 $\frac{3}{4}$	21 $\frac{3}{4}$	28	29	34
J (SPRAG N.R.)	3 $\frac{13}{16}$	4 $\frac{5}{16}$	4 $\frac{1}{2}$	4 $\frac{1}{2}$	3- $\frac{15}{16}$	4 $\frac{13}{16}$	4 $\frac{5}{8}$	4 $\frac{5}{8}$	6 $\frac{7}{8}$	6 - $\frac{13}{16}$	1/5/1900
J (PIN TYPE N.R.)	4 $\frac{3}{4}$	5	5 $\frac{3}{16}$	5 $\frac{1}{4}$	5 $\frac{1}{16}$	5 $\frac{7}{8}$	5- $\frac{9}{16}$	5 $\frac{9}{16}$	8- $\frac{1}{8}$	-	-
K (SPRAG N.R.)	6 $\frac{9}{16}$	6 $\frac{7}{16}$	6 $\frac{3}{16}$	6 $\frac{3}{16}$	8- $\frac{1}{4}$	8- $\frac{1}{4}$	8 $\frac{1}{4}$	8 $\frac{1}{4}$	8 $\frac{3}{4}$	9 $\frac{13}{16}$	12 $\frac{1}{2}$
K (PIN TYPE N.R.)	5 $\frac{5}{8}$	5 $\frac{3}{4}$	5 $\frac{1}{2}$	5 $\frac{1}{2}$	7- $\frac{3}{16}$	7- $\frac{3}{16}$	7 $\frac{1}{8}$	7 $\frac{1}{8}$	7- $\frac{1}{2}$	-	-
L	1 $\frac{1}{4}$	1 $\frac{1}{2}$	1 $\frac{1}{2}$	1 $\frac{1}{2}$	1- $\frac{3}{4}$	1- $\frac{3}{4}$	$\frac{3}{4}$	1 $\frac{3}{4}$	1 $\frac{1}{4}$	1 $\frac{1}{4}$	2/3/2008
MNPS	$\frac{1}{2}$	$\frac{1}{2}$	$\frac{1}{2}$	$\frac{1}{2}$	$\frac{1}{2}$	$\frac{1}{2}$	$\frac{1}{2}$	$\frac{1}{2}$	$\frac{1}{2}$	$\frac{1}{2}$	$\frac{1}{2}$
N	5 $\frac{5}{8}$	9 $\frac{1}{8}$	9 $\frac{1}{8}$	9 $\frac{1}{8}$	12- $\frac{3}{8}$	12- $\frac{3}{8}$	12 $\frac{3}{8}$	12 $\frac{3}{8}$	20	20	13
O	5 $\frac{3}{4}$	5 $\frac{3}{4}$	5 $\frac{3}{4}$	5 $\frac{3}{4}$	5 $\frac{3}{4}$	5 $\frac{3}{4}$	5 $\frac{3}{4}$	5 $\frac{3}{4}$	7 $\frac{1}{2}$	7 $\frac{1}{2}$	10
P	1 $\frac{3}{4}$	1 $\frac{7}{8}$	1 $\frac{7}{8}$	1 $\frac{7}{8}$	2- $\frac{1}{2}$	2- $\frac{1}{2}$	2 $\frac{1}{2}$	2 $\frac{1}{2}$	1 $\frac{1}{4}$	1 $\frac{1}{4}$	2 $\frac{1}{4}$
Q	3 $\frac{1}{8}$	3 $\frac{3}{4}$	3 $\frac{3}{4}$	3 $\frac{3}{4}$	4- $\frac{1}{2}$	4- $\frac{1}{2}$	4 $\frac{1}{2}$	4 $\frac{1}{2}$	3 $\frac{3}{16}$	3 $\frac{3}{16}$	11 $\frac{7}{16}$
RNPS	$\frac{1}{2}$	$\frac{1}{2}$	$\frac{1}{2}$	$\frac{1}{2}$	$\frac{1}{2}$	$\frac{1}{2}$	$\frac{1}{2}$	$\frac{1}{2}$	$\frac{1}{2}$	$\frac{1}{2}$	$\frac{1}{2}$
S	4 $\frac{1}{2}$	4 $\frac{5}{8}$	4 $\frac{5}{8}$	4 $\frac{5}{8}$	5 $\frac{7}{8}$	5- $\frac{7}{8}$	5 $\frac{7}{8}$	5 $\frac{7}{8}$	1 $\frac{1}{4}$	1 $\frac{1}{4}$	2 $\frac{1}{4}$
T	9 $\frac{1}{4}$	10 $\frac{3}{4}$	10 $\frac{3}{4}$	10 $\frac{3}{4}$	15- $\frac{5}{8}$	15- $\frac{5}{8}$	15 $\frac{5}{8}$	15 $\frac{5}{8}$	22	22	20
V	2	2	2	2 $\frac{1}{2}$	2- $\frac{1}{2}$	2 $\frac{1}{2}$	3	3	4	4	5
W	5 $\frac{1}{4}$	6 $\frac{1}{2}$	6 $\frac{1}{2}$	6 $\frac{1}{2}$	7- $\frac{3}{4}$	7- $\frac{3}{4}$	7 $\frac{3}{4}$	7 $\frac{3}{4}$	12	12	8- $\frac{11}{16}$
NET WT.	250	320	335	380	680	690	740	745	1,500	1810	3000
DOMESTIC WT. (LB.)	275	345	360	406	718	728	778	783	1,547	1857	3100
EXPORT WT. (LB.)	340	420	435	480	820	830	880	885	1,720	2030	3250
EXPORT CU. FT.	9.5	9.5	9.5	10.3	17.5	17.5	17.5	17.5	38.9	38.9	55
OIL CAP. (QTS)	6	7	7	7	13	13	13	13	24	24	50

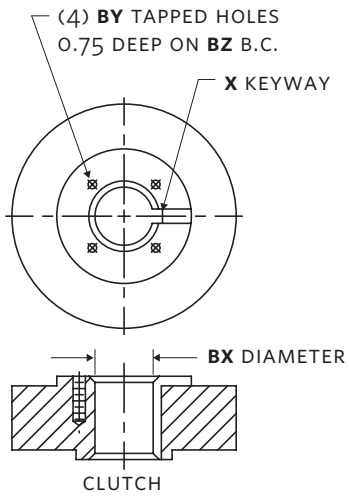

BX BORE	X KEYWAY	BY TAP	BZ B.C.
3/4	3/16 x 3/32	10-32	1.375
7/8	1/4 x 1/8	10-32	1.375
1	1/4 x 1/8	10-32	1.375
1 1/16	1/4 x 1/8	10-32	1.375
1 3/16	1/4 x 1/8	1/4-20	1.750
1 1/4	1/4 x 1/8	1/4-20	1.750
1 7/16	3/8 x 3/16	1/4-20	2.125
1 1/2	3/8 x 3/16	1/4-20	2.125
1 11/16	3/8 x 3/16	1/4-20	2.500
1 3/4	3/8 x 3/16	1/4-20	2.500
1 15/16	1/2 x 1/4	1/4-20	2.500
2	1/2 x 1/4	1/4-20	2.500
2 3/46	1/2 x 1/4	3/8-16	3.250
2 1/4	1/2 x 1/4	3/8-16	3.250
2 7/16	5/8 x 5/16	3/8-16	3.250
2 1/2	5/8 x 5/16	3/8-16	3.750
2 11/16	5/8 x 5/16	3/8-16	3.750
2 3/4	5/8 x 5/16	3/8-16	3.750
2 15/16	3/4 x 3/8	3/8-16	3.750
3 3/16	3/4 x 3/8	3/8-16	4.250
3 7/16	7/8 x 7/16	3/8-16	4.750
3 1/2	7/8 x 7/16	3/8-16	4.750
3 11/16	7/8 x 7/16	3/8-16	4.750
3 3/4	7/8 x 7/16	3/8-16	4.750
4	1 x 1/2	3/8-16	4.750
4 1/4	1 x 1/2	3/8-16	5.000

TORONTO

23 BERTRAND AVENUE
TORONTO, ONTARIO
CANADA
M1L 2P3
+1 416 755 2291

BUFFALO

93 EAST AVENUE
NORTH TONAWANDA, NEW YORK
U.S.A.
14120-6594
+1 716 693 8813

BIRMINGHAM

HEYWOOD WHARF, MUCKLOW HILL
HALESOWEN, WEST MIDLANDS
UNITED KINGDOM
B62 8DJ
+44 (0) 8444 145 145

MANCHESTER

WENLOCK WAY
MANCHESTER
UNITED KINGDOM
M12 5JL
+44 (0) 8444 145 145

BANGALORE

#59, FIRST FLOOR, 3RD MAIN
MARGOSA ROAD, MALLESWARAM
BANGALORE, INDIA
560 003
+91 (0) 80 4906 3555

SHANGHAI

NO. 1619 HU HANG ROAD, XI DU TOWNSHIP
FENG XIAN DISTRICT, SHANGHAI
P.R.C.
201401
+86 21 3756 6696

ARMSTRONG FLUID TECHNOLOGY
ESTABLISHED 1934

ARMSTRONGFLUIDTECHNOLOGY.COM

**MAKING
ENERGY
MAKE
SENSE™**