

VERTICAL TURBINE DIESEL FIRE PUMP | 4000 GPM WITH 12x24½ FABRICATED STEEL HEAD | SUBMITTAL

File No: F51.644
Date: JULY 15, 2013
Supersedes: F51.644
Date: AUGUST 15, 2005

Job: _____ Representative: _____
 _____ Order no.: _____ Date: _____
 Engineer: _____ Submitted by: _____ Date: _____
 Contractor: _____ Approved by: _____ Date: _____

Model: 12x18H VTF **Discharge head:** 12x24½ F

RPM: 1770 Water lube

4000 GPM: _____ T.D.H

- FM UL NFPA-20 only
- Approval Construction
- Engine model: _____
- Ragd model: _____
- Shaft model: _____
- Controller model: _____

NOTES

- Dimension based on randolph gear drive. May vary when driver adaptor is required.
- Dimensions are in inches unless otherwise indicated.
- Engine to base mounting and cooling loop to be field installed and plumbed.
- Engine oil & anti freeze/coolant may not be included.
- Gear shipped filled with oil. Check level before installation.
- Refer dwg. no. _____ for Engine dimensions.
- Not to be used for construction unless certified.

PRESS RATE	DISCHARGE FLANGE INCH (mm)					
	DA	DC	DD	DF	DG	DK
300#	20.50 (521)	17.75 (451)	17.00 (432)	12.00 (304)	1.25 (32)	2.00 (51)



NO OF STG'S	DISCHARGE SIZE	RATING	RAGD	AG*	B	C	H*	I*	L	AA
	INCH (mm)		HP	INCH (mm)						
3	12.00 (305)	300	500-750	45.44 (1154)	66.88 (1699)	2.25 (57)	18.75 (476)	28.00 (711)	-	-

* Dimension based on randolph gear drive. May vary when driver adaptor is required.

SUBMITTAL
4000 GPM

Vertical turbine diesel Fire pump
4000 GPM with 12x24½ Fabricated steel head

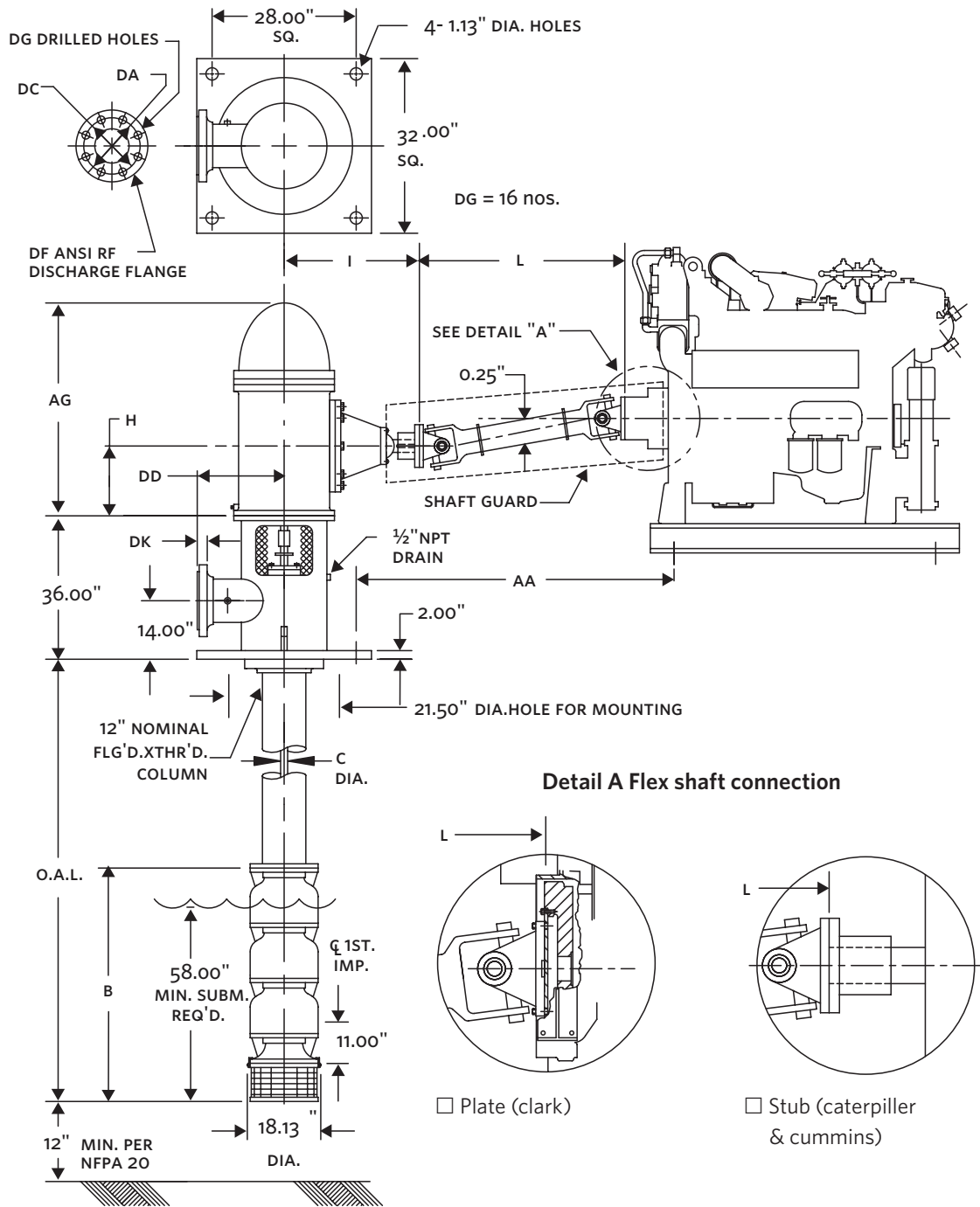

TORONTO
+1 416 755 2291

BUFFALO
+1 716 693 8813

BIRMINGHAM
+44 (0) 8444 145 145

MANCHESTER
+44 (0) 8444 145 145

BANGALORE
+91 (0) 80 4906 3555

SHANGHAI
+86 21 3756 6696

ARMSTRONG FLUID TECHNOLOGY
ESTABLISHED 1934

ARMSTRONGFLUIDTECHNOLOGY.COM