

VERTICAL TURBINE DIESEL FIRE PUMP | 750 GPM WITH 8×16½ CAST IRON HEAD | SUBMITTAL

File No: F51.608
Date: JULY 15, 2013
Supersedes: F51.608
Date: AUGUST 15, 2005

Job: _____ Representative: _____

_____ Order no.: _____ Date: _____

Engineer: _____ Submitted by: _____ Date: _____

Contractor: _____ Approved by: _____ Date: _____

Model: 8 × 12M VTF **Discharge head:** 8 × 16½ A

RPM: 1770 Water lube

750 GPM: _____ T.D.H

- FM UL NFPA-20 only
- Approval Construction
- Engine model: _____
- Ragd model: _____
- Shaft model: _____
- Controller model: _____

NOTES

- Dimension based on randolph gear drive. May vary when driver adaptor is required.
- Dimensions are in inches unless otherwise indicated.
- Engine to base mounting and cooling loop to be field installed and plumbed.
- Engine oil & anti freeze/coolant may not be included.
- Gear shipped filled with oil. Check level before installation.
- Refer dwg. no. _____ for Engine dimensions.
- Not to be used for construction unless certified.

PRESS RATE	DISCHARGE FLANGE INCH (mm)					
	DA	DC	DD	DF	DG	DK
125 #	13.50 (343)	11.75 (299)	11.50 (292)	8.00 (203)	0.88 (22)	1.13 (29)
250 #	15.00 (381)	13.00 (330)	12.00 (305)	8.00 (203)	1.00 (25)	1.63 (41)



NO OF STG'S	DISCHARGE SIZE	RATING	RAGD	AG*	B	C	H*	I*	L	AA
	INCH (mm)		HP	INCH (mm)						
5	8.00 (203)	250	100	22.25 (565)	68.63 (1743)	1.25 (32)	8.50 (216)	17.00 (432)	—	—
5	8.00 (203)	250	125	26.69 (678)	68.63 (1743)	1.25 (32)	11.44 (291)	18.00 (457)	—	—
6	8.00 (203)	250	100	22.25 (565)	78.00 (1981)	1.50 (38)	11.44 (291)	17.00 (432)	—	—
6	8.00 (203)	250	125	26.69 (678)	78.00 (1981)	1.50 (38)	11.44 (291)	18.00 (457)	—	—
7	8.00 (203)	250	125-150	26.69 (678)	87.38 (2220)	1.50 (38)	11.44 (291)	18.00 (457)	—	—
8	8.00 (203)	250	150	26.69 (678)	96.75 (2458)	1.50 (38)	11.44 (291)	18.00 (457)	—	—
8	8.00 (203)	250	200	29.94 (761)	96.75 (2458)	1.50 (38)	11.44 (291)	18.00 (457)	—	—
9	8.00 (203)	250	200	29.94 (761)	106.13 (2696)	1.50 (38)	11.44 (291)	18.00 (457)	—	—
10	8.00 (203)	250	200	29.94 (761)	115.50 (2934)	1.50 (38)	11.44 (291)	18.00 (457)	—	—
10	8.00 (203)	250	250	34.00 (864)	115.50 (2934)	1.69 (43)	13.75 (349)	21.75 (553)	—	—
11	8.00 (203)	250	250	34.00 (864)	117.88 (2994)	1.69 (43)	13.75 (349)	21.75 (553)	—	—

* Dimension based on randolph gear drive. May vary when driver adaptor is required.

SUBMITTAL
750 GPM

Vertical turbine diesel Fire pump
750 GPM with 8 × 16½ Cast iron head

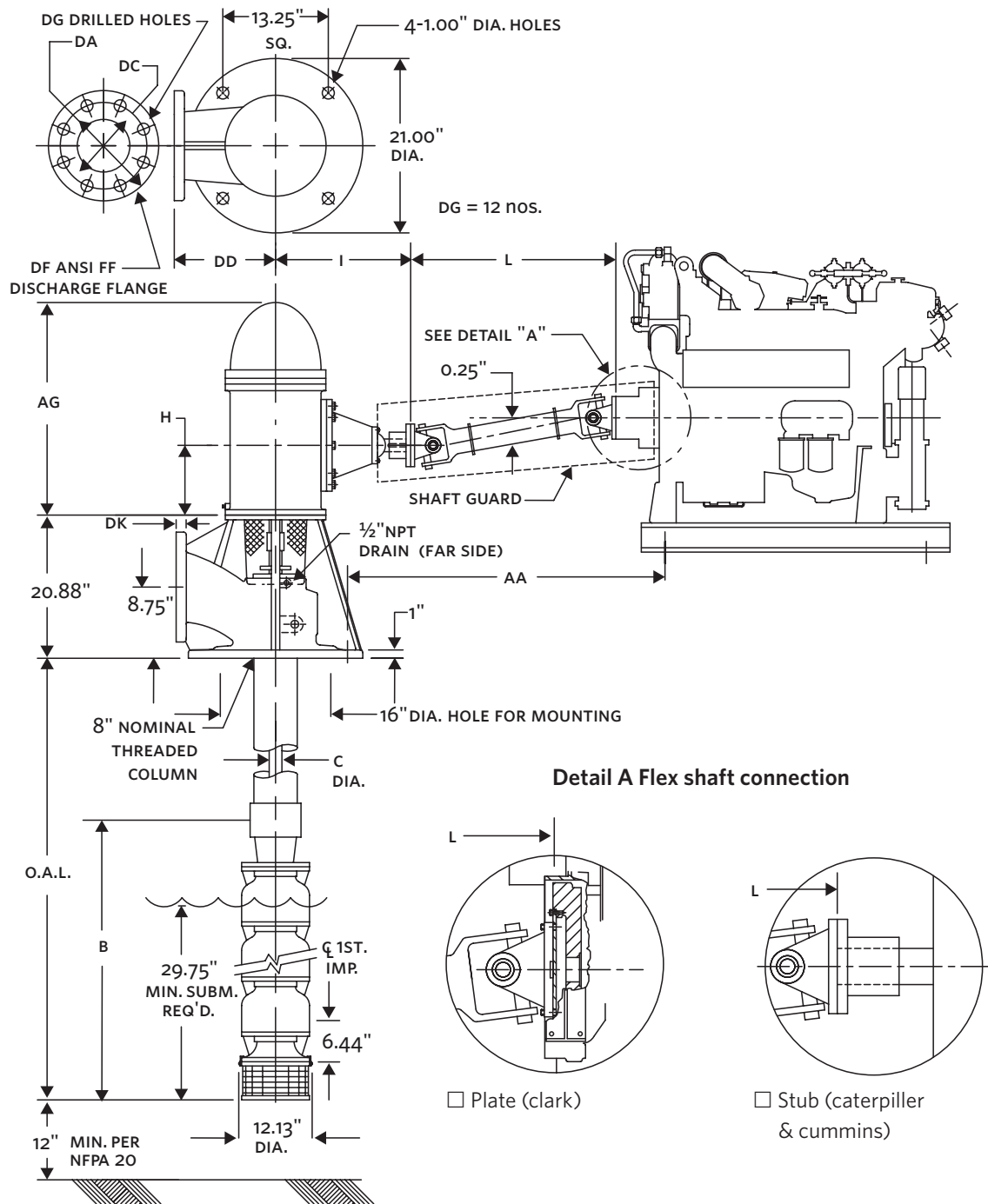

TORONTO
+1 416 755 2291

BUFFALO
+1 716 693 8813

BIRMINGHAM
+44 (0) 8444 145 145

MANCHESTER
+44 (0) 8444 145 145

BANGALORE
+91 (0) 80 4906 3555

SHANGHAI
+86 21 3756 6696

ARMSTRONG FLUID TECHNOLOGY
ESTABLISHED 1934

ARMSTRONGFLUIDTECHNOLOGY.COM