

VERTICAL TURBINE DIESEL FIRE PUMP | 500 GPM WITH 6×16½ CAST IRON HEAD | SUBMITTAL

File No: F51.604
Date: JULY 15, 2013
Supersedes: F51.604
Date: AUGUST 15, 2005

Job: _____ Representative: _____
 _____ Order no.: _____ Date: _____
 Engineer: _____ Submitted by: _____ Date: _____
 Contractor: _____ Approved by: _____ Date: _____

Model: 6 × 10H VTF **Discharge head:** 6 × 16½ A

RPM: 1770 Water lube

500 GPM: _____ T.D.H

- FM UL NFPA-20 only
- Approval Construction
- Engine model: _____
- Ragd model: _____
- Shaft model: _____
- Controller model: _____

NOTES

- Dimension based on randolph gear drive. May vary when driver adaptor is required.
- Dimensions are in inches unless otherwise indicated.
- Engine to base mounting and cooling loop to be field installed and plumbed.
- Engine oil & anti freeze/coolant may not be included.
- Gear shipped filled with oil. Check level before installation.
- Refer dwg. no. _____ for Engine dimensions.
- Not to be used for construction unless certified.

PRESS RATE	DISCHARGE FLANGE INCH (mm)					
	DA	DC	DD	DF	DG	DK
250 #	12.50 (318)	10.63 (270)	10.69 (272)	6.00 (152)	0.88 (22)	1.44 (37)



NO OF STG'S	DISCHARGE SIZE	RATING	RAGD	AG*	B	C	H*	I*	L	AA
	INCH (mm)		HP	INCH (mm)						
8	6 (152)	250	60-80	22.25 (565)	88.94 (2259)	1.25 (32)	8.50 (216)	17.00 (432)	—	—
9	6 (152)	250	80	22.25 (565)	97.44 (2475)	1.25 (32)	8.50 (216)	17.00 (432)	—	—
10	6 (152)	250	80-100	22.25 (565)	105.94 (2691)	1.25 (32)	8.50 (216)	17.00 (432)	—	—
11	6 (152)	250	100	22.25 (565)	114.44 (2907)	1.25 (32)	8.50 (216)	17.00 (432)	—	—
12	6 (152)	250	100	22.25 (565)	122.94 (3123)	1.25 (32)	8.50 (216)	17.00 (432)	—	—
12	6 (152)	250	125	26.69 (678)	122.94 (3123)	1.25 (32)	11.44 (291)	18.00 (457)	—	—
13	6 (152)	250	125	26.69 (678)	131.44 (3339)	1.25 (32)	11.44 (291)	18.00 (457)	—	—

* Dimension based on randolph gear drive. May vary when driver adaptor is required.

SUBMITTAL
500 GPM

Vertical turbine diesel Fire pump
500 GPM with 6 × 16½ Cast iron head

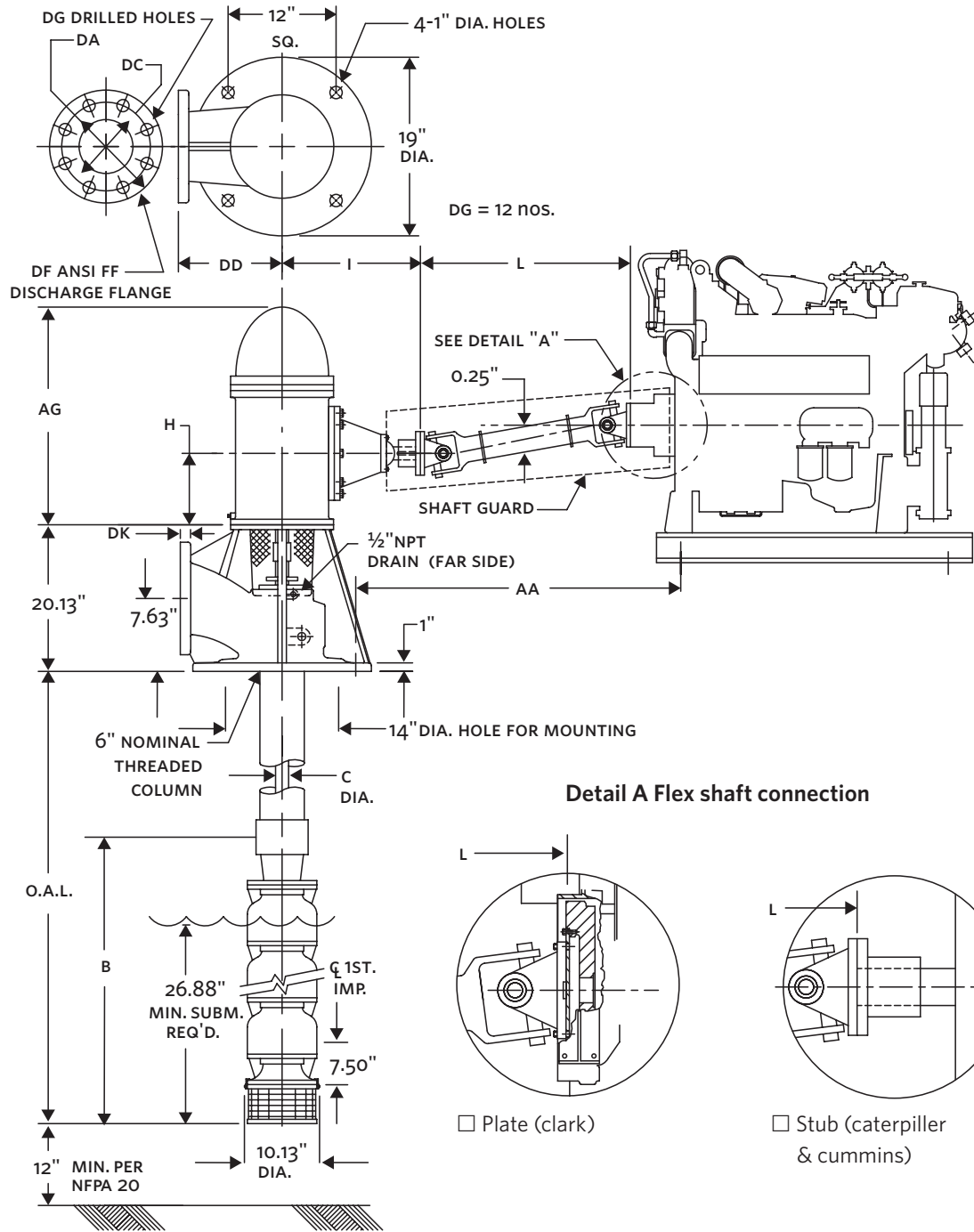

TORONTO
+1 416 755 2291

BUFFALO
+1 716 693 8813

BIRMINGHAM
+44 (0) 8444 145 145

MANCHESTER
+44 (0) 8444 145 145

BANGALORE
+91 (0) 80 4906 3555

SHANGHAI
+86 21 3756 6696

ARMSTRONG FLUID TECHNOLOGY
ESTABLISHED 1934

ARMSTRONGFLUIDTECHNOLOGY.COM