

HORIZONTAL SPLIT CASE PUMP | SERIES 4600F | ELECTRIC DRIVEN | 5x4x12HF | SUBMITTAL

File No: F46.510
Date: SEPTEMBER 25, 2018
Supersedes: F46.510
Date: AUGUST 10, 2016

Job: _____ Representative: _____
 _____ Order no.: _____ Date: _____
 Engineer: _____ Submitted by: _____ Date: _____
 Contractor: _____ Approved by: _____ Date: _____

PUMP DESIGN DATA

Flow: _____
 Head: _____

ENCLOSURE: _____
 SPECIAL STARTING: _____

FLANGE RATING

- ANSI 125# STD¹
- ANSI 125# Suction
250# Discharge
- ANSI 250# Suction
250# Discharge
- PN 16

MOTOR DATA

HP: _____ RPM: _____
 Volt: _____ ph: _____ Hz: _____

FIRE PUMP LISTING

- UL
- ULC
- FM

To be indicated by customer

- Suction side (viewed from driver end)
 Right hand (shown) Left hand

NOTES

- 1 Std. Discharge flange thickness ANSI 250#.
- 2 Coupling guard not shown.
- 3 All dimensions for engine connections are with reference to engine manufacturer's installation drawings.
- 4 Do not use for construction unless certified.

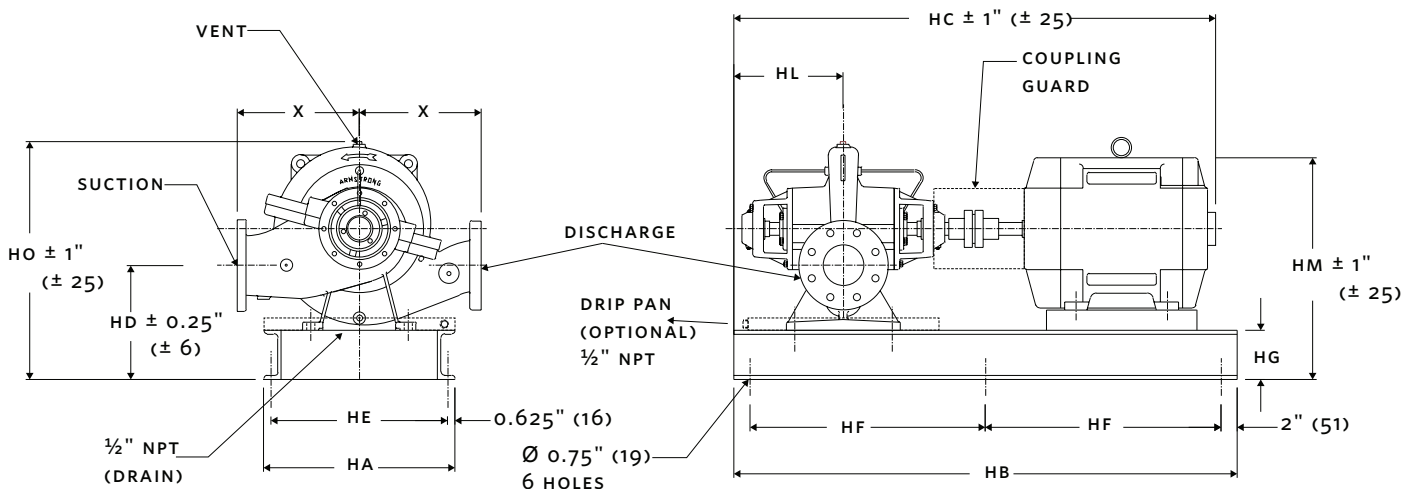

2

MOTOR FRAME	DIMENSIONS inches (mm)											WEIGHT lbs(kg)
	HA	HB	HC	HD	HE	HF	HG	HL	HM	HO	X	
256T	16.00 (406)	54.00 (1372)	53.69 (1364)	9.50 (241)	14.76 (375)	25.00 (635)	3.00 (76)	13.50 (343)	20.10 (511)	21.94 (557)	13.00 (330)	805 (365.1)
284TS	19.00 (483)	58.00 (1473)	54.00 (1372)	10.50 (267)	17.76 (451)	27.00 (686)	4.00 (102)	13.50 (343)	21.22 (539)	22.94 (583)	13.00 (330)	855 (387.8)
286TS	19.00 (483)	58.00 (1473)	54.00 (1372)	10.50 (267)	17.76 (451)	27.00 (686)	4.00 (102)	13.50 (343)	21.22 (539)	22.94 (583)	13.00 (330)	875 (396.9)

TORONTO
+1 416 755 2291

BUFFALO
+1 716 693 8813

BIRMINGHAM
+44 (0) 8444 145 145

MANCHESTER
+44 (0) 8444 145 145

BANGALORE
+91 (0) 80 4906 3555

SHANGHAI
+86 21 3756 6696

SÃO PAULO
+55 11 4785 1330