

**HORIZONTAL SPLIT CASE PUMP | SERIES 4600F |**  
**DIESEL DRIVEN | 8x6x16F | SUBMITTAL**

File No: F46.562  
Date: SEPTEMBER 25, 2018  
Supersedes: F46.562  
Date: AUGUST 10, 2016

Job: \_\_\_\_\_ Representative: \_\_\_\_\_  
\_\_\_\_\_ Order no.: \_\_\_\_\_ Date: \_\_\_\_\_  
Engineer: \_\_\_\_\_ Submitted by: \_\_\_\_\_ Date: \_\_\_\_\_  
Contractor: \_\_\_\_\_ Approved by: \_\_\_\_\_ Date: \_\_\_\_\_

**PUMP DESIGN DATA**

Flow: \_\_\_\_\_  
Head: \_\_\_\_\_

**ENGINE DESIGN DATA**

HP: \_\_\_\_\_ RPM: \_\_\_\_\_  
Bat. Voltage: \_\_\_\_\_ Tank size: \_\_\_\_\_  
Other: \_\_\_\_\_

**NOTES**

- 1 Std. Discharge flange thickness ANSI 250#.
- 2 Coupling guard not shown.
- 3 All dimensions for engine connections are with reference to engine manufacturer's installation drawings.
- 4 Do not use for construction unless certified.
- 5 Right hand rotation only.

**FLANGE RATING**

- ANSI 125# STD<sup>1</sup>
- ANSI 125# Suction  
250# Discharge
- ANSI 250#
- PN 16

**FIRE PUMP LISTING**

- UL
- ULC
- FM

**ACCESSORIES**

- Exhaust system
- Fuel system
- Cooling system (mounted on engine)
- Battery system

8x6x16F	HORIZONTAL SPLIT CASE DIESEL DRIVEN	DIMENSIONS inches (mm)							WEIGHT
		C	HA	HB	HE	HF	HM	Z	lbs (kg)
Clarke	JU4H series	86.02 (2185)	32.00 (813)	82.00 (2083)	30.00 (762)	39.00 (991)	58.42 (1484)	18.00 (457)	2192 (994.5)
	JU6H series	96.10 (2441)	32.00 (813)	95.00 (2413)	30.00 (762)	45.50 (1156)	58.70 (1491)	18.00 (457)	3024 (1371.7)
	JW6H series	102.40 (2601)	32.00 (813)	100.00 (2540)	30.00 (762)	32.00 (813)	64.60 (1641)	21.67 (550)	3409 (1546.5)
Cummins	CFP33 series	76.13 (1934)	32.00 (813)	82.00 (2083)	30.00 (762)	39.00 (991)	41.66 (1058)	17.13 (435)	1998 (906.3)
	CFP59 series	87.45 (2221)	32.00 (813)	95.00 (2413)	30.00 (762)	45.50 (1156)	47.44 (1205)	18.00 (457)	2712 (1230.2)
	CFP83 series	95.55 (2427)	32.00 (813)	100.00 (2540)	30.00 (762)	32.00 (813)	49.02 (1245)	18.00 (457)	3090 (1401.7)
	CFP5E series	85.99 (2184)	32.00 (813)	95.00 (2413)	30.00 (762)	45.50 (1156)	47.53 (1207)	18.00 (457)	2597 (1177.8)
	CFP7E series	96.94 (2462)	32.00 (813)	100.00 (2540)	30.00 (762)	32.00 (813)	47.53 (1207)	18.00 (457)	2775 (1258.8)
	CFP9E series	98.73 (2508)	32.00 (813)	100.00 (2540)	30.00 (762)	32.00 (813)	49.63 (1261)	18.00 (457)	3195 (1449.3)

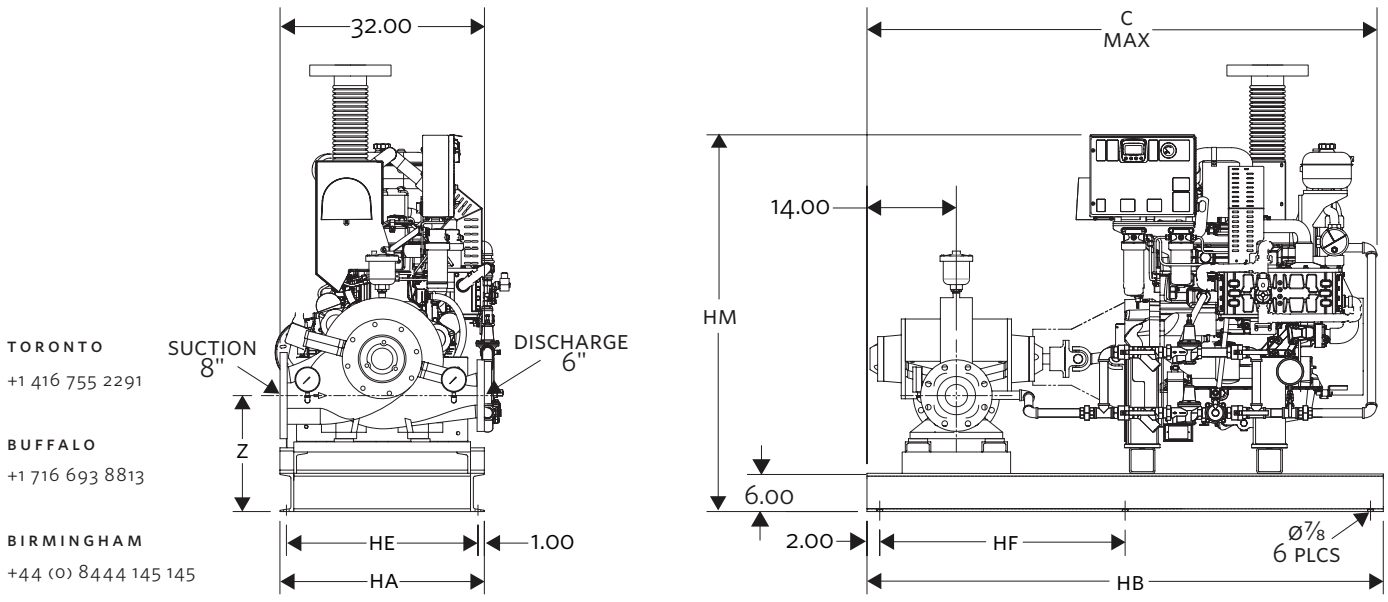

TORONTO  
+1 416 755 2291

BUFFALO  
+1 716 693 8813

BIRMINGHAM  
+44 (0) 8444 145 145

MANCHESTER  
+44 (0) 8444 145 145

BANGALORE  
+91 (0) 80 4906 3555

SHANGHAI  
+86 21 3756 6696

SÃO PAULO  
+55 11 4785 1330