

HORIZONTAL SPLIT CASE PUMP | SERIES 4600F | ELECTRIC DRIVEN | 12x8x20F | SUBMITTAL

File No: F46.5282
Date: JULY 18, 2023
Supersedes: NEW
Date: NEW

Job: _____ Representative: _____

Order no.: _____ Date: _____

Engineer: _____ Submitted by: _____ Date: _____

Contractor: _____ Approved by: _____ Date: _____

PUMP DESIGN DATA

Flow: _____

Head: _____

ENCLOSURE: _____

SPECIAL STARTING: _____

FLANGE RATING

- ANSI 125# STD¹
- ANSI 125# Suction
250# Discharge
- ANSI 250# Suction
250# Discharge
- PN 16

MOTOR DATA

HP: _____ RPM: _____

Volt: _____ ph: _____ Hz: _____

FIRE PUMP LISTING

- UL
- ULC
- FM

To be indicated by customer

Suction side (viewed from driver end)

- Right hand (shown) Left hand

NOTES

- 1 Std. Discharge flange thickness ANSI 250#.
- 2 Coupling guard not shown.
- 3 All dimensions for engine connections are with reference to engine manufacturer's installation drawings.
- 4 Do not use for construction unless certified.

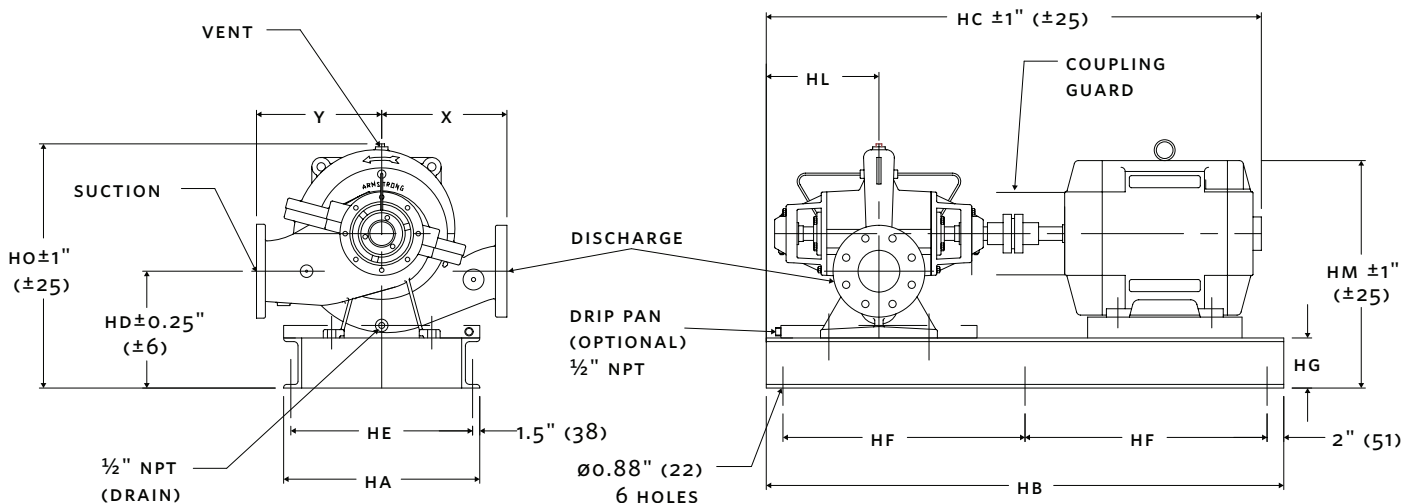

MOTOR FRAME	DIMENSIONS inches (mm)												WEIGHT lbs (kg)
	HA	HB	HC	HD	HE	HF	HG	HL	HM	HO	X	Y	
404TS	32.00 (813)	80.00 (2032)	70.90 (1802)	16.10 (410)	29.00 (737)	38.00 (965)	6.00 (152)	16.90 (428)	39.00 (989)	45.50 (1156)	19.60 (499)	19.60 (499)	3237 (1468.3)
405TS	32.00 (813)	80.00 (2032)	70.90 (1802)	16.10 (410)	29.00 (737)	38.00 (965)	6.00 (152)	16.90 (428)	39.00 (989)	45.50 (1156)	19.60 (499)	19.60 (499)	3237 (1468.3)
444TS	32.00 (813)	80.00 (2032)	75.90 (1927)	17.10 (435)	29.00 (737)	38.00 (965)	6.00 (152)	16.90 (428)	42.60 (1082)	46.50 (1182)	19.60 (499)	19.60 (499)	3559 (1614.4)
445TS	32.00 (813)	80.00 (2032)	75.90 (1927)	17.10 (435)	29.00 (737)	38.00 (965)	6.00 (152)	16.90 (428)	42.60 (1082)	46.50 (1182)	19.60 (499)	19.60 (499)	3659 (1659.8)
447TS	32.00 (813)	100.00 (2540)	79.10 (2010)	16.10 (410)	29.00 (737)	48.00 (1219)	6.00 (152)	16.90 (428)	41.20 (1046)	45.50 (1156)	19.60 (499)	19.60 (499)	4122 (1869.8)
449TS	32.00 (813)	100.00 (2540)	79.10 (2010)	16.10 (410)	29.00 (737)	48.00 (1219)	6.00 (152)	16.90 (428)	41.20 (1046)	45.50 (1156)	19.60 (499)	19.60 (499)	4122 (1869.8)

TORONTO

+1 416 755 2291

BUFFALO

+1 716 693 8813

DROITWICH SPA

+44 121 550 5333

MANCHESTER

+44 161 223 2223

BANGALORE

+91 80 4906 3555

SHANGHAI

+86 21 5237 0909

BEIJING

+86 21 5237 0909

SÃO PAULO

+55 11 4785 1330

LYON

+33 4 26 83 78 74

DUBAI

+971 4 887 6775

JIMBOLIA

+40 256 360 030

FRANKFURT

+49 6173 999 77 55