

## Series 4600 Horizontal Split Case

## SUBMITTAL

JOB: _____	REPRESENTATIVE: _____
ENGINEER: _____	ORDER NO: _____ DATE: _____
CONTRACTOR: _____	SUBMITTED BY: _____ DATE: _____
	APPROVED BY: _____ DATE: _____

TAG/REF:										
PUMP DATA	FLOW	HEAD	MOTOR DATA	HP	RPM	VOLT	PH	Hz	ENCLOSURE	

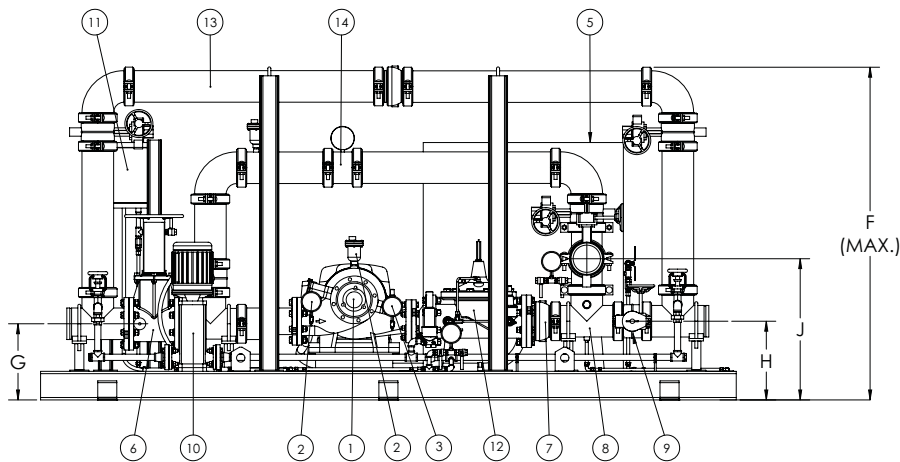
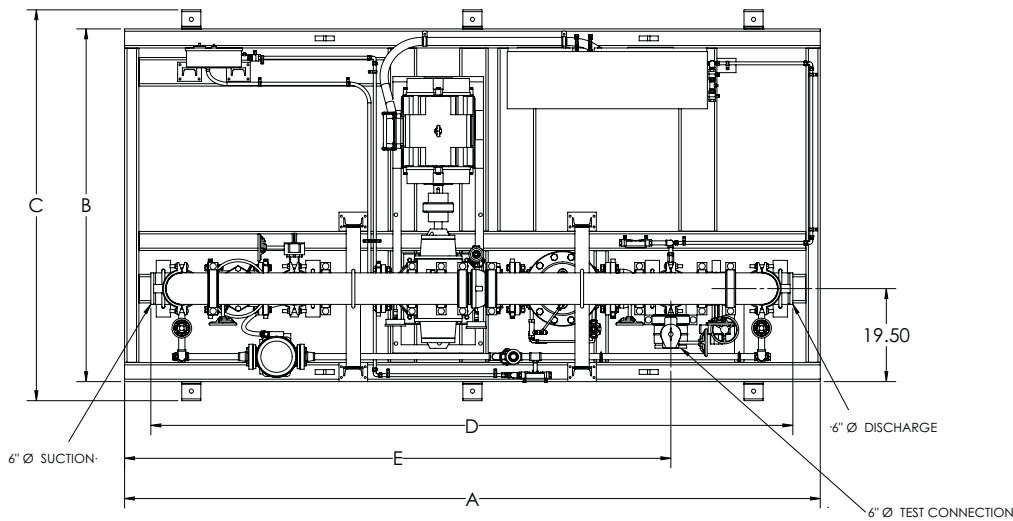

PUMP MODEL	HP	MAX. DIMENSIONS Inches (mm)									MAX. WEIGHT lbs (kg)
		A	B	C	D	E	F	G	H	J	
5x4x10LF	40-100	146.00 (3708)	74.00 (1880)	82.00 (2083)	134.73 (3422)	114.62 (2911)	72.00 (1829)	15.97 (406)	16.50 (419)	29.62 (752)	6,800 (3084.4)
5x4x12HF	20	146.00 (3708)	66.00 (1676)	74.00 (1880)	136.73 (3473)	115.62 (2937)	70.00 (1778)	14.97 (380)	15.50 (394)	28.62 (727)	5,300 (2404.0)
5x4x12HF	25-30	146.00 (3708)	74.00 (1880)	82.00 (2083)	136.73 (3473)	115.62 (2937)	70.00 (1778)	15.97 (406)	16.50 (419)	29.62 (752)	5,500 (2494.8)

ITEM No.	DESCRIPTION	QTY.
1	HSC FIRE PUMP & MOTOR	1
2	PUMP SUCTION / DISCHARGE GAUGE	2
3	PUMP CASING AIR RELEASE VALVE	1
4	PUMP CASING RELIEF VALVE	1
5	FIRE PUMP CONTROLLER	1
6	SUCTION OS&Y GATE VALVE, 6" FLANGED	1
7	CHECK VALVE, 6" GROOVED	1
8	TEST TEE, 6" GROOVED	1
9	DISCHARGE BUTTERFLY VALVE, 6" GROOVED	1
10	VMS JOCKEY PUMP & MOTOR	1 (OPT)
11	JOCKEY PUMP CONTROLLER (OPTIONAL)	1 (OPT)
12	SUCTION CONTROL VALVE, 6" FLANGED	1 (OPT)
13	CITY BYPASS LOOP, c/w 6" CHECK VALVE & 6" ISOLATION BUTTERFLY VALVES	1 (OPT)
14	FLOW METER LOOP c/w 6" VENTURI METER, AIR RELEASE & 6" ISOLATION BUTTERFLY VALVES	1 (OPT)

**S. A. Armstrong Limited**  
 23 Bertrand Avenue  
 Toronto, Ontario  
 Canada, M1L 2P3  
 T: 416-755-2291  
 F: 416-759-9101

**Armstrong Pumps Inc.**  
 93 East Avenue  
 North Tonawanda, New York  
 U.S.A. 14120-6594  
 T: 716-693-8813  
 F: 716-693-8970

**Armstrong Integrated Limited**  
 Wenlock Way  
 Manchester  
 United Kingdom, M12 5JL  
 T: +44 (0) 8444 145 145  
 F: +44 (0) 8444 145 146

