

BATTERY SYSTEM SUBMITTAL DRAWING

File No: F43.455
 Date: MAY 11, 2012
 Supersedes: F43.455
 Date: OCTOBER 15, 2004

Job: _____ Representative: _____

Order No: _____ Date: _____

Engineer: _____ Submitted by: _____ Date: _____

Contractor: _____ Approved by: _____ Date: _____

12 VOLT DUAL BATTERY SYSTEM LEAD-ACID TYPE

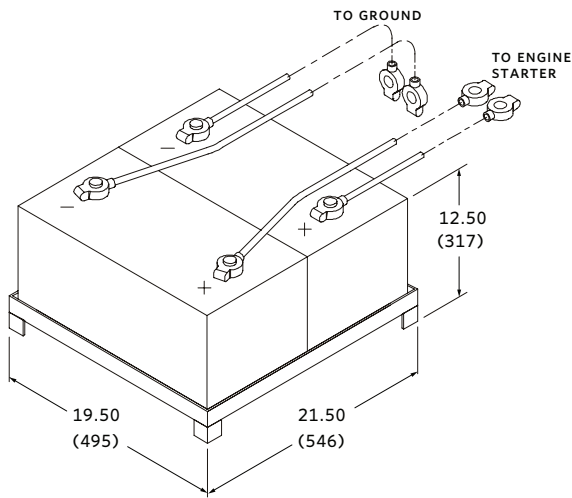

24 VOLT DUAL BATTERY SYSTEM LEAD-ACID TYPE

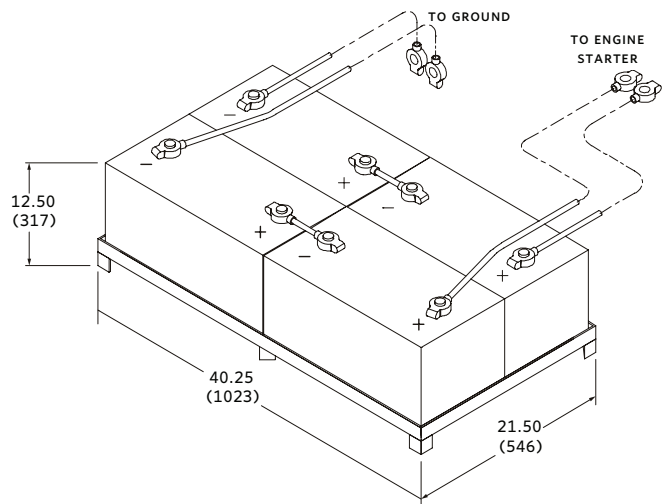

NOTES:

- 1 All cables awg # 2/0 x 5' - 0" long
- 2 Shipping weight
 12 v system dry: 140 lbs. (64 kg)
 24 v system dry: 270 lbs. (123 kg)
- 3 Acid shipped separately
 20 litres / 2 batteries: 58 lbs. (26 kg) as per NFPA-20 2010 edition section 11.2.7.2.1
- 4 Acid not supplied when shipped by ocean freight and air freight
- 5 Dimensions are not used for construction purposes unless certified.
- 6 Data subject to change without notice.
- 7 All dimensions are in inches (mm).

TORONTO

23 BERTRAND AVENUE
TORONTO, ONTARIO
CANADA
M1L 2P3
+416 755 2291

BUFFALO

93 EAST AVENUE
NORTH TONAWANDA, NEW YORK
U.S.A.
14120-6594
+716 693 8813

BIRMINGHAM

HEYWOOD WHARF, MUCKLOW HILL
HALESOWEN, WEST MIDLANDS
UNITED KINGDOM
B62 8DJ
+44 (0) 8444 145 145

MANCHESTER

WENLOCK WAY
MANCHESTER
UNITED KINGDOM
M12 5JL
+44 (0) 8444 145 145

BANGALORE

#59, FIRST FLOOR, 3RD MAIN
MARGOSA ROAD, MALLESWARAM
BANGALORE, INDIA
560 003
+91 (0) 80 4906 3555

SHANGHAI

NO. 1619 HU HANG ROAD, XI DU TOWNSHIP
FENG XIAN DISTRICT, SHANGHAI
P.R.C.
201401
+86 21 3756 6696

ARMSTRONG INTEGRATED
ESTABLISHED 1934

ARMSTRONGINTEGRATED.COM

**MAKING
ENERGY
MAKE
SENSE™**