



**Series 4302 IVS Design Envelope**  
**Models: 10CN2, 10CO2, 10CP2**

**10C\_2**

FILE NO: 100.592L  
 DATE: Mar. 03, 2009  
 SUPERSEDES: New  
 DATE: New

**SUBMITTAL**

JOB: \_\_\_\_\_ REPRESENTATIVE: \_\_\_\_\_

ENGINEER: \_\_\_\_\_ ORDER NO: \_\_\_\_\_ DATE: \_\_\_\_\_

CONTRACTOR: \_\_\_\_\_ SUBMITTED BY: \_\_\_\_\_ DATE: \_\_\_\_\_

APPROVED BY: \_\_\_\_\_ DATE: \_\_\_\_\_

PUMP DESIGN DATA			
NO. OF PUMPS:			
TAG:			
CAPACITY:	L/s (USgpm)	HEAD:	m (ft.)
LIQUID:		VISCOSITY:	
TEMPERATURE:	°C (°F)	SPECIFIC GRAVITY:	

MOTOR DESIGN DATA		
KW:		
FRAME SIZE:	ENCLOSURE:	
VOLTS:	HERTZ: 50 Hz	PHASE: 3
EFFICIENCY: <input type="checkbox"/> EFF 2 <input type="checkbox"/> EFF 1		
FLANGE SIZE: SUCTION: 150 mm (6")		DISCHARGE: 150 mm (6")

DESIGN ENVELOPE CAPABILITY DATA					
MODEL	FLOW Lps (USgpm)	HEAD m (ft)	EFF%	MOTOR kW	RPM
<input type="checkbox"/> 10CN2	80 (1267)	58 (189)	71.8	37	2690
<input type="checkbox"/> 10CO2	45 (705)	61 (200)	65.0	45	3050
<input type="checkbox"/> 10CP2	52 (817)	83 (271)	65.0	55	3550

DRIVE DATA	
SENSORLESS CONTROL:	<input type="checkbox"/> REQUIRED <input type="checkbox"/> NOT REQUIRED
*MINIMUM SYSTEM PRESSURE TO BE MAINTAINED _____ m (ft)	
FIELDBUS PROTOCOL: <input type="checkbox"/> ModBUS RTU (standard) <input type="checkbox"/> LonWorks <input type="checkbox"/> BACnet	
ENCLOSURE: IP55	
EMI/RFI CONTROL: Integrated Filter designed to meet EN61800-3	
HARMONIC SUPPRESSION: Integrated DC Link Reactors (<5% THD)	
COOLING: Fan-cooled through back channel	
AMBIENT TEMPERATURE: -10°C to +45°C up to 1000 meters above sea level (-14°F TO +113°F, 3280ft)	
ANALOG INPUTS: 2, current or voltage	
ANALOG OUTPUTS: 1, current	
DIGITAL INPUTS: 4 Programmable	
DIGITAL OUTPUTS: 2 Programmable (can be configured as additional digital inputs)	
PULSE INPUTS: 2 Programmable	
RELAY OUTPUTS: 2 Programmable	
COMMUNICATION PORT: RS 485	
**EXPANSION CARD OPTION	
Drive A	<input type="checkbox"/> Auxiliary Analog I/O <input type="checkbox"/> Auxiliary Digital I/O <input type="checkbox"/> Auxiliary Relay <input type="checkbox"/> Real-Time Clock
Drive B	<input type="checkbox"/> Auxiliary Analog I/O <input type="checkbox"/> Auxiliary Digital I/O <input type="checkbox"/> Auxiliary Relay <input type="checkbox"/> Real-Time Clock

MATERIALS OF CONSTRUCTION		
DIN FLANGE RATING	<input type="checkbox"/> PN16 CAST IRON <input type="checkbox"/> PN25 Ductile Iron	
CONSTRUCTION	BF	DBF
CASING	CAST IRON	DUCTILE IRON
IMPELLER	BRONZE	BRONZE
FLUSH LINE	COPPER	COPPER
PUMP SHAFT	416 STAINLESS STEEL	
COUPLING	HIGH TENSILE ALUMINUM	
GASKET	CONFINED NON-ASBESTOS	

MAXIMUM PUMP OPERATING CONDITIONS	
PN16 Cast Iron	PN25 Ductile Iron
12 bars at 60°C (175 psig at 140°F) 7 bars at 149°C (100 psig at 300°F)	26 bars at 38°C (375 psig at 100°F) 19 bars at 260°C (275 psig at 500°F)
SEE FILE NO. 43.50 FOR MAXIMUM SEAL OPERATING CONDITIONS	

MECHANICAL SEAL DESIGN DATA
See File No. 43.50 for standard mechanical
Armstrong Seal Reference Number
<input type="checkbox"/> C1 (a) Other _____

SEAL DATA OPTIONS

OPTIONAL EQUIPMENT
SEE FILE NO. 43.50 FOR ENVIRONMENTAL ACCESSORIES



# Series 4302 IVS Design Envelope

Models: 10CN2, 10CO2, 10CP2

# 10C\_2

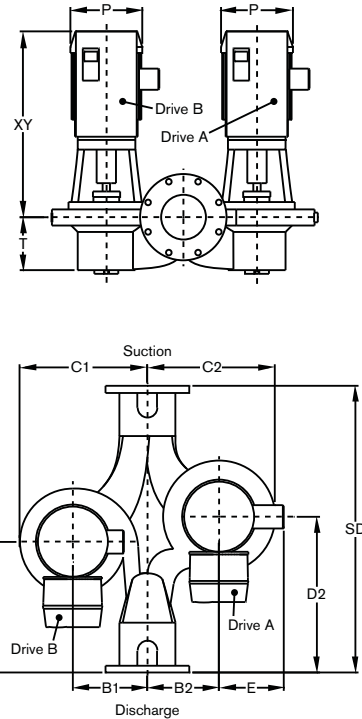
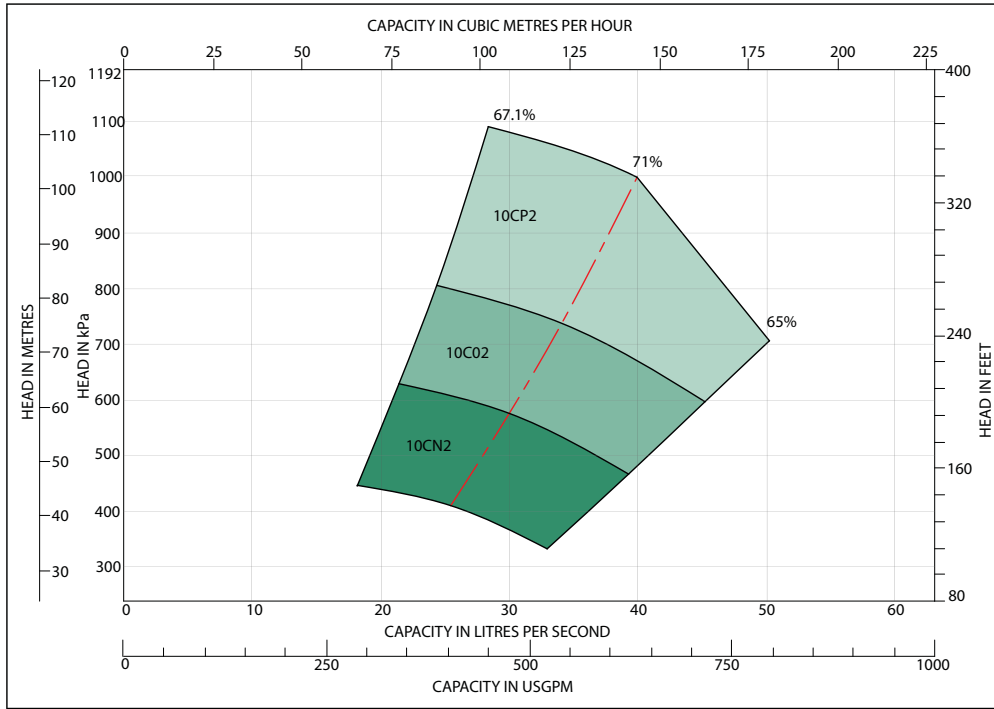

### DIMENSION DATA - mm (inches)

Curve No.	Size	Power (kW)	C1	C2	D1	D2	B1	B2	T	SD	ODP motors with UL Type 12 drives			TEFC motors with UL Type 12 drives			Weight in lbs (Kg)	
											P	E	XY	P	E	XY	ODP	TEFC
10CN2	150-250	37	448 (17.63)	473 (18.63)	394 (15.50)	476 (18.75)	254 (10.00)	254 (10.00)	195 (7.66)	914 (36.00)	359 (14.13)	322 (12.69)	977 (38.48)	432 (17.00)	353 (13.91)	1125 (44.29)	725.6 (1600)	929.7 (2050)
10CO2	150-250	45	448 (17.63)	473 (18.63)	394 (15.50)	476 (18.75)	254 (10.00)	254 (10.00)	195 (7.66)	914 (36.00)	359 (14.13)	322 (12.69)	977 (38.48)	483 (19.03)	418 (16.44)	1082 (42.60)	752.8 (1660)	1047.6 (2310)
10CP2	150-250	55	448 (17.63)	473 (18.63)	394 (15.50)	476 (18.75)	254 (10.00)	254 (10.00)	195 (7.66)	914 (36.00)	449 (17.68)	411 (16.19)	1014 (39.91)	483 (19.03)	418 (16.44)	1082 (42.60)	920.6 (2030)	1083.9 (2390)

- COUPLING GUARD (NOT SHOWN) IS SUPPLIED.
- TOLERANCE OF ±0.125" (±3 mm) SHOULD BE USED.
- FOR EXACT INSTALLATION DATA PLEASE WRITE FACTORY FOR CERTIFIED DIMENSIONS.
- PUMP EQUIPPED WITH CASING DRAIN PLUG AND 1/4" NPT SUCTION AND DISCHARGE GAUGE PORTS

**S. A. Armstrong Limited**  
 23 Bertrand Avenue  
 Toronto, Ontario  
 Canada, M1L 2P3  
 T: (416) 755-2291  
 F (Main): (416) 759-9101

**Armstrong Pumps Inc.**  
 93 East Avenue  
 North Tonawanda, New York  
 U.S.A. 14120-6594  
 T: (716) 693-8813  
 F: (716) 693-8970

**Armstrong Holden Brooke Pullen**  
 Wenlock Way  
 Manchester  
 United Kingdom, M12 5JL  
 T: +44 (0) 161 223 2223  
 F: +44 (0) 161 220 9660



© S.A. Armstrong Limited 2009

For Armstrong locations worldwide, please visit [www.armstrongpumps.com](http://www.armstrongpumps.com)