

# AGE3 CIRCULATOR | SINGLE-HEAD VARIABLE SPEED | 25-100 | SUBMITTAL

File No: 10.8526IEC  
Date: FEBRUARY 25, 2020  
Supersedes: 10.8526IEC  
Date: MAY 10, 2017

Job: \_\_\_\_\_ Representative: \_\_\_\_\_  
 \_\_\_\_\_ Ordered by: \_\_\_\_\_ Date: \_\_\_\_\_  
 Engineer: \_\_\_\_\_ Submitted by: \_\_\_\_\_ Date: \_\_\_\_\_  
 Contractor: \_\_\_\_\_ Approved by: \_\_\_\_\_ Date: \_\_\_\_\_

## PUMP DETAILS

TAG	MODEL	FLOW	HEAD	SYSTEM	LOCATION

### MOTOR DESIGN DATA

**Motor enclosure:** IP44  
**Power supply:** 230/1/50  
**Insulation class:** F  
**Motor efficiency:**  $EEI \leq 0.21$   
**Inverter/motor type:** ECM/Permanent magnet  
**Motor speed:** Variable speed

### ELECTRICAL DATA

1x230,50HZ, IEC38	P1[W]	I [AMPS]
Auto min.	10	0.10
Auto max.	180	1.50

### ELECTRICAL CONNECTION

**Type:** 3 wires (L,N,Earth)  
**Connector:** 3 pins connector & cable gland

### BMS CONNECTIVITY

**Input/output:** 1 x analogue I/O, 1 x digital I/O and 1 x relay  
**Serial communication:** Modbus RTU and Ethernet

### MATERIALS OF CONSTRUCTION

**Impeller:** PES  
**Casing gasket:** EPDM 70 Shore  
**Bearings:** Graphite  
**Pump casing:** Cast iron  
**Shaft:** Stainless steel  
**Can:** Stainless steel

### MECHANICAL CONNECTION

**Type:** Threaded  
**Pressure rating:** PN10  
**Size:** G1½"

### ENVIRONMENT LIMIT DATA

**Water temp max:** 110°C  
**Water temp min :** 2°C  
**Ambient temp. max:** 40°C  
**Min. pressure:** 0.05 BAR < 75°C,  
 0.28 BAR < 90°C

**DIMENSIONS**

A	B	C	D	E	WEIGHT
mm (inches)					kg (lbs)
180 (7.1)	95 (3.7)	180 (7.1)	58.5 (2.3)	58.5 (2.3)	3.2 (7.0)

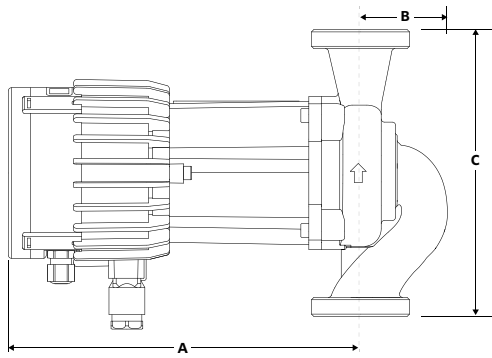
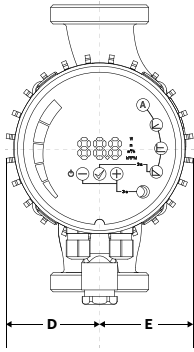

H (kpa)

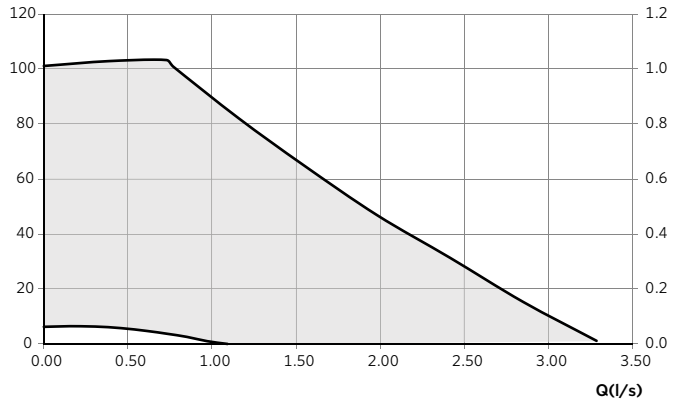

P (W)

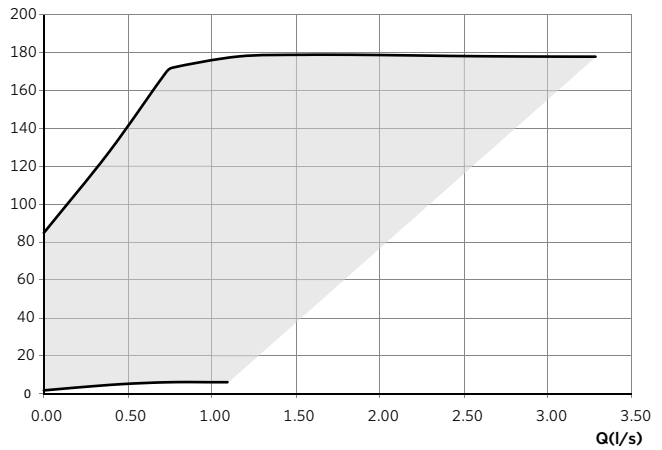

**TORONTO**

+1 416 755 2291

**BUFFALO**

+1 716 693 8813

**BIRMINGHAM**

+44 (0) 8444 145 145

**MANCHESTER**

+44 (0) 8444 145 145

**BANGALORE**

+91 (0) 80 4906 3555

**SHANGHAI**

+86 (0) 21 5237 0909

**SÃO PAULO**

+55 11 4785 1330

**LYON**

+33 (0) 420 102 625

**DUBAI**

+971 4 887 6775

**MANNHEIM**

+49 (0) 621 3999 9858