

SERIES 4700 VERTICAL MULTI-STAGE PUMP VMS 10 | SUBMITTAL

File No: 47.510
Date: NOVEMBER 28, 2014
Supersedes: 47.510
Date: APRIL 07, 2011

Job: _____ Representative: _____

Ordered by: _____ Date: _____

Engineer: _____ Submitted by: _____ Date: _____

Contractor: _____ Approved by: _____ Date: _____

PUMP DESIGN DATA

No. of pumps: _____ Tag: _____
Capacity: _____ USgpm (L/s) Head: _____ ft (m)
Liquid: _____ Viscosity: _____
Temperature: _____ °F (°C) Specific gravity: _____
Suction: 2" (51mm) Discharge: 2" (51mm)
Maximum working temperature: 250°F (120°C)

MATERIALS OF CONSTRUCTION

Flange rating: ANSI 250
Pump casing: EN 1.4301 (AISI 304)
Impellers: EN 1.4301 (AISI 304)
Stage casing: EN 1.4301 (AISI 304)
Diffusers: EN 1.4301 (AISI 304)
Pump shaft: EN 1.4401 (AISI 316)
Jacket tube: EN 1.4301 (AISI 304)
Intermediate bearing: Tungsten carbide
O rings: FPM
Motor pedestal: Cast iron EN-GJL-200-EN 1561
Pump base: Cast iron EN-GJL-200-EN 1561
Mechanical seal faces: Silicon carbide/Carbon/FPM

MOTOR DESIGN DATA

HP: _____ RPM: 3600 Frame size: _____
Enclosure: ODP TEFC Volts: _____
Hertz: 60 Hz Phase: 1 3
Efficiency*: NEMA premium 12.12 Other: _____%

*Fractional power, frame 56 & 1-phase motors are supplied with the standard efficiency of the Manufacturer.

REMARKS

PUMP SIZE	HP	NEMA FRAME	MWP*	DIMENSIONS in inches(mm)		WEIGHT in lbs (kg)
				HC	P	
VMS 1002	1.5	143TC	232	25.77 (654)	8.63 (219)	163 (73.9)
VMS 1003	3	145TC	232	28.51 (724)	8.63 (219)	184 (83.5)
VMS 1004	3	145TC	232	30.08 (764)	8.63 (219)	196 (88.9)
VMS 1005	5	184TC	232	35.36 (898)	10.38 (264)	226 (102.5)
VMS 1006	5	184TC	232	36.55 (928)	10.38 (264)	233 (105.7)
VMS 1008	7.5	184TC	232	40.43 (1027)	10.38 (264)	283 (128.4)
VMS 1010	7.5	213TC	370	43.40 (1102)	10.38 (264)	288 (130.6)
VMS 1012	10	215TC	370	46.88 (1191)	11.25 (286)	361 (163.7)
VMS 1014	15	215TC	370	49.41 (1255)	11.25 (286)	395 (179.2)
VMS 1016	15	215TC	370	51.77 (1315)	11.25 (286)	420 (190.5)

All dimensions are in inches (mm) and are approximate.

*Maximum Working Pressure

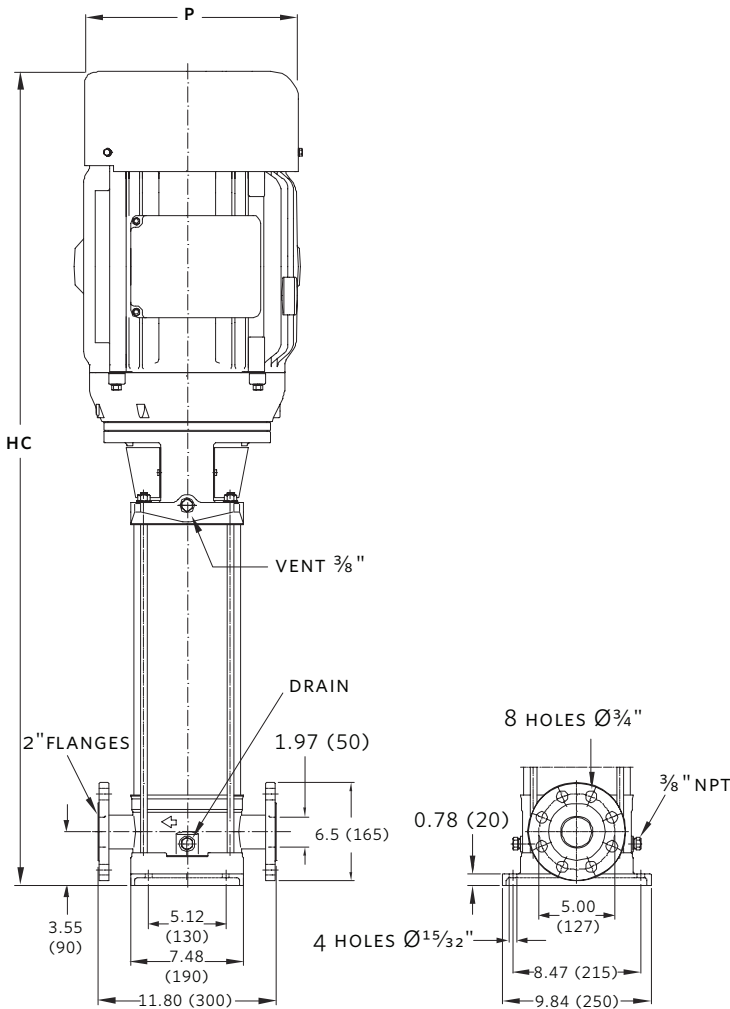

SERIES 4700 PERFORMANCE CURVES

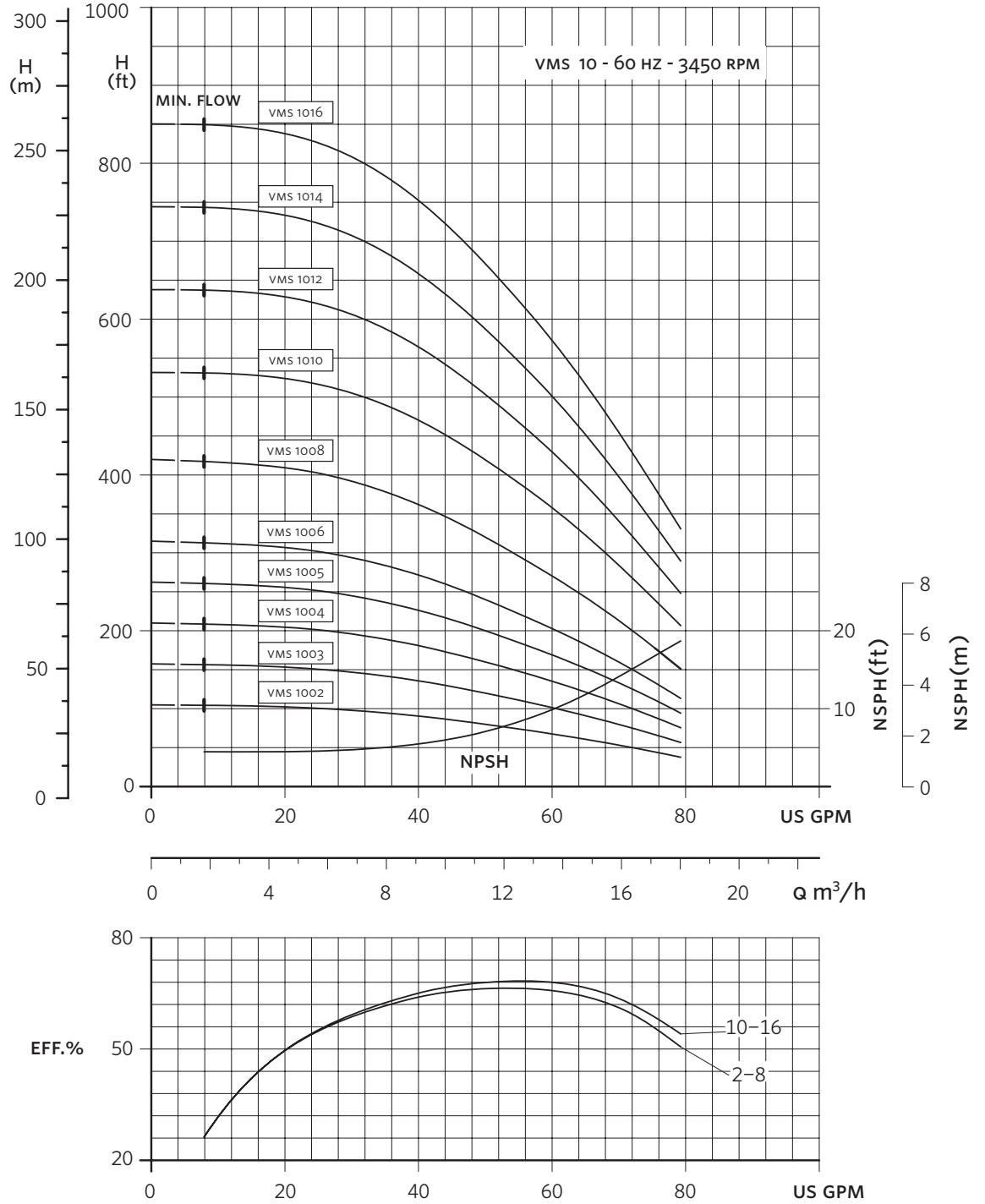

Performance curves are for reference only.
Confirm current performance data with Armstrong ACE ONLINE selection software.

TORONTO

23 BERTRAND AVENUE
TORONTO, ONTARIO
CANADA
M1L 2P3
+416 755 2291

BUFFALO

93 EAST AVENUE
NORTH TONAWANDA, NEW YORK
U.S.A.
14120-6594
+716 693 8813

BIRMINGHAM

HEYWOOD WHARF, MUCKLOW HILL
HALESOWEN, WEST MIDLANDS
UNITED KINGDOM
B62 8DJ
+44 (0) 8444 145 145

MANCHESTER

WOLVERTON STREET
MANCHESTER
UNITED KINGDOM
M11 2ET
+44 (0) 8444 145 145

BANGALORE

#59, FIRST FLOOR, 3RD MAIN
MARGOSA ROAD, MALLESWARAM
BANGALORE, INDIA
560 003
+91 (0) 80 4906 3555

SHANGHAI

NO. 1619 HU HANG ROAD, XI DU TOWNSHIP
FENG XIAN DISTRICT, SHANGHAI
P.R.C.
201401
+86 21 3756 6696

**MAKING
ENERGY
MAKE
SENSE™**