

## SERIES 4382 | VERTICAL IN-LINE DUALARM CLOSED-COUPLED | 8 × 8 × 8 | SUBMITTAL

File No: 43D.722  
Date: DECEMBER 4, 2014  
Supersedes: 43D.722  
Date: SEPTEMBER 10, 2012

Job: \_\_\_\_\_ Representative: \_\_\_\_\_  
 \_\_\_\_\_ Order no.: \_\_\_\_\_ Date: \_\_\_\_\_  
 Engineer: \_\_\_\_\_ Submitted by: \_\_\_\_\_ Date: \_\_\_\_\_  
 Contractor: \_\_\_\_\_ Approved by: \_\_\_\_\_ Date: \_\_\_\_\_

### PUMP DESIGN DATA

No. of pumps: \_\_\_\_\_ Tag: \_\_\_\_\_  
 Capacity: \_\_\_\_\_ USgpm (L/s) Head: \_\_\_\_\_ ft (m)  
 Liquid: \_\_\_\_\_ Viscosity: \_\_\_\_\_  
 Temperature: \_\_\_\_\_ °F (°C) Specific gravity: \_\_\_\_\_  
 Suction: 8" (200mm) Discharge: 8" (200mm)

### MOTOR DESIGN DATA

HP: \_\_\_\_\_ RPM: \_\_\_\_\_ Frame size: \_\_\_\_\_ Enclosure: \_\_\_\_\_  
 Volts: \_\_\_\_\_ Hertz: 60 Hz Phase: 3  
 Efficiency:  Energy EFF 12.11  NEMA premium 12.12

### MATERIALS OF CONSTRUCTION

ANSI FLANGE RATING	ANSI 125	ANSI 250
<b>Construction</b>	<input type="checkbox"/> BF	<input type="checkbox"/> DBF
<b>Casing</b>	Cast iron	Ductile iron
<b>Adapter</b>	Cast iron	Ductile iron

**Impeller:** Bronze  
**Gasket:** Confined non-asbestos fiber  
**Shaft:** Carbon steel  
**Shaft sleeve:** Bronze  
**Flush line:** Braided stainless steel

### MAXIMUM PUMP OPERATING CONDITIONS

**ANSI 125**  
 175 psig at 150°F (12 bars at 65°C)  
 140 psig at 250°F (10 bars at 121°C)  
**ANSI 250**  
 250 psig at 150°F (17 bars at 65°C)  
 250 psig at 250°F (17 bars at 121°C)

- Coupling guard (not shown) is supplied
- See performance curves on page 3
- For exact installation, data please write factory for certified dimensions

### MECHANICAL SEAL DATA

**Seal type:** 2A  
**Stationary seat:** Silicone carbide  
**Secondary seal:** EPDM  
**Rotating hardware:** Stainless steel  
**Spring:** Stainless steel

### OPTIONAL EQUIPMENT

FLUID TYPE	ALL GLYCOLS > 30% WT CONC		ALL OTHER NON-POTABLE FLUIDS		POTABLE (DRINKING) WATER	
	up to 200°F (93°C)	over 200°F (93°C)	up to 200°F (93°C)	over 200°F (93°C)	up to 200°F (93°C)	over 200°F (93°C)
<b>Temperature</b>	up to 200°F (93°C)	over 200°F (93°C)	up to 200°F (93°C)	over 200°F (93°C)	up to 200°F (93°C)	over 200°F (93°C)
<b>Rotating face</b>	Silicone carbide		Resin bonded carbon	Antimony loaded carbon	Resin bonded carbon	
<b>Seat elastomer</b>	EPDM (L-cup)	EPDM (O-ring)	EPDM (L-cup)	EPDM (O-ring)	EPDM (L-cup)	EPDM (O-ring)
<b>Material code</b>	SCSc L EPSS 2A	SCSc O EPSS 2A	C-SC L EPSS 2A	ACSc O EPSS 2A	C-SC L EPSS 2A	C-SC O EPSS 2A

MOTOR	HP @ RPM		MAX. DIMENSIONS inches (mm)				WEIGHT	
	1800	1200	E1	E2	P	XY	lbs (kgs)	
FRAME							ODP	TEFC
213JP	—	3	8.25 (210)	8.25 (210)	12.13 (308)	26.08 (662)	828 (375.6)	960 (435.4)
215JP	—	5	8.25 (210)	8.25 (210)	12.13 (308)	26.08 (662)	886 (401.9)	1018 (461.8)
215JP	10	—	8.25 (210)	8.25 (210)	12.13 (308)	26.08 (662)	1170 (530.7)	1228 (557.0)
254JM	15	—	9.94 (252)	9.94 (252)	12.13 (308)	25.45 (646)	1242 (563.4)	1312 (595.1)
256JM	20	—	9.94 (252)	9.94 (252)	12.13 (308)	25.45 (646)	1242 (563.4)	1312 (595.1)

**PUMP DIMENSIONS**  
inches (mm)

B1	B2	C1	C2	D1	D2	SD	T
10.00	9.00	18.50	18.60	18.50	23.00	45.50	9.46
(254)	(229)	(470)	(472)	(470)	(584)	(1156)	(240)

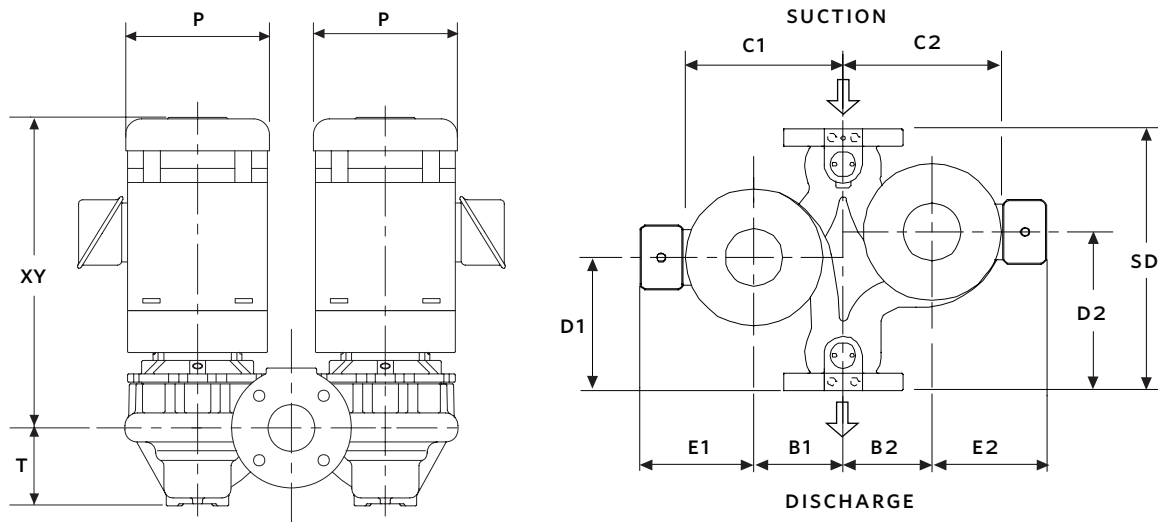

## SERIES 4382 PERFORMANCE CURVES

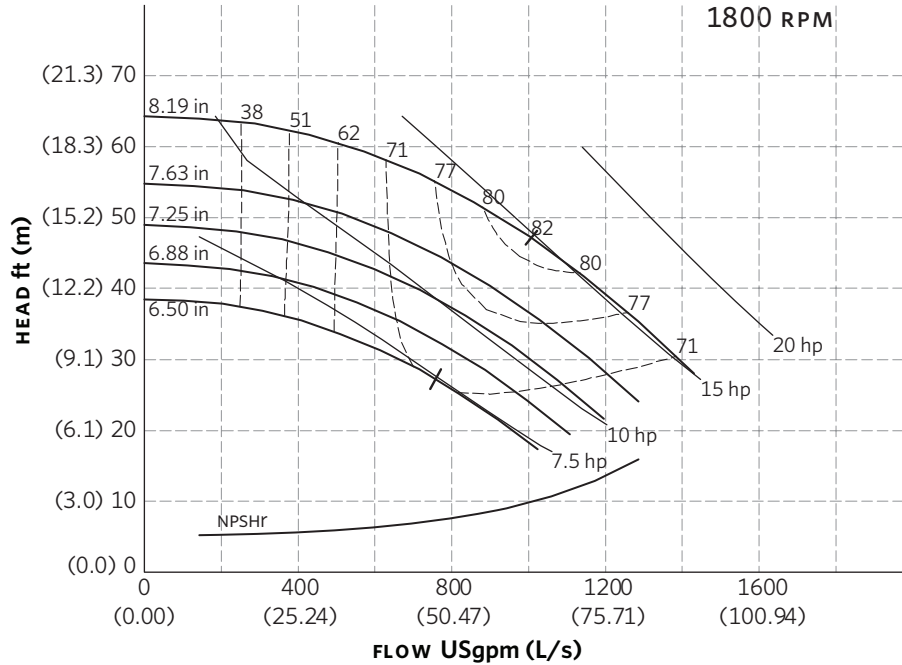

**Curve number**  
PT107-2-0-1800

**Series**  
4302  
4382

**Size**  
8 × 8 × 8

**RPM**  
1800

BHP based on shown  
Fluid's sp. gr.

**Availability**  
4302 all ratings  
4382 all ratings

Performance  
guaranteed only  
at operating point  
indicated.  
Curve shown for  
clear, cold water  
- SP. GR. 1.0000

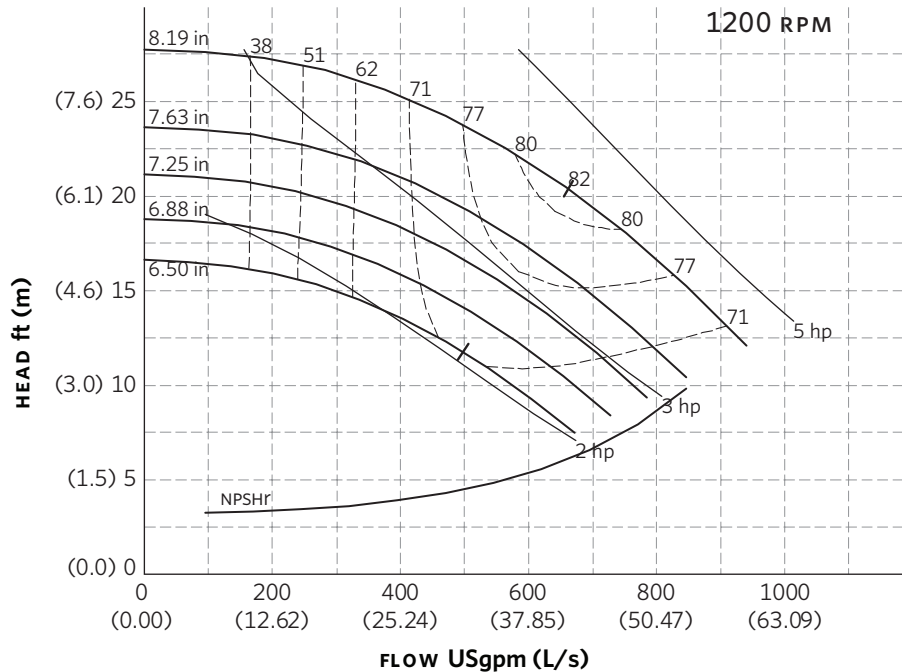

**Curve number**  
PT107-2-0-1200

**Series**  
4302  
4382

**Size**  
8 × 8 × 8

**RPM**  
1200

BHP based on shown  
Fluid's sp. gr.

**Availability**  
4302 all ratings  
4382 all ratings

Performance  
guaranteed only  
at operating point  
indicated.  
Curve shown for  
clear, cold water  
- SP. GR. 1.0000

Performance curves are for reference only.  
Confirm current performance data with Armstrong ACE ONLINE selection software.

**TORONTO**

23 BERTRAND AVENUE  
TORONTO, ONTARIO  
CANADA  
M1L 2P3  
+416 755 2291

**BUFFALO**

93 EAST AVENUE  
NORTH TONAWANDA, NEW YORK  
U.S.A.  
14120-6594  
+716 693 8813

**BIRMINGHAM**

HEYWOOD WHARF, MUCKLOW HILL  
HALESOWEN, WEST MIDLANDS  
UNITED KINGDOM  
B62 8DJ  
+44 (0) 8444 145 145

**MANCHESTER**

WOLVERTON STREET  
MANCHESTER  
UNITED KINGDOM  
M11 2ET  
+44 (0) 8444 145 145

**BANGALORE**

#59, FIRST FLOOR, 3RD MAIN  
MARGOSA ROAD, MALLESWARAM  
BANGALORE, INDIA  
560 003  
+91 (0) 80 4906 3555

**SHANGHAI**

NO. 1619 HU HANG ROAD, XI DU TOWNSHIP  
FENG XIAN DISTRICT, SHANGHAI  
P.R.C.  
201401  
+86 21 3756 6696

**MAKING  
ENERGY  
MAKE  
SENSE™**