

SERIES 4380 | CLOSED-COUPLED VERTICAL IN-LINE | 40-150A (1.5x1.5x6) | SUBMITTAL

File No: 43.701L
Date: APRIL 04, 2016
Supersedes: NEW
Date: NEW

Job: _____ Representative: _____
 _____ Order no.: _____ Date: _____
 Engineer: _____ Submitted by: _____ Date: _____
 Contractor: _____ Approved by: _____ Date: _____

PUMP DESIGN DATA

No. of pumps: _____ Tag: _____
 Capacity: _____ m³/h (USgpm) Head: _____ m(ft)
 Liquid: _____ Viscosity: _____
 Temperature: _____ °C (°F) Specific gravity: _____
 Suction: 40mm (1.5") Discharge: 40mm (1.5")

MATERIALS OF CONSTRUCTION

DIN FLANGE RATING	PN 16	PN 25
Construction	<input type="checkbox"/> BF	<input type="checkbox"/> DBF
Casing	Cast iron	Ductile iron
Adapter	Cast iron	Ductile iron

Impeller: Bronze

Gasket: Confined non-asbestos fiber

Shaft: Carbon steel

Shaft sleeve: Bronze

Flush line: Braided stainless steel

MECHANICAL SEAL DATA

Seal type: 2A **Stationary seat:** Silicone carbide
Secondary seal: EPDM **Rotating hardware:** Stainless steel
Spring: Stainless steel

MOTOR DESIGN DATA

kW: _____ RPM: _____
 Frame size: _____ Enclosure: _____
 Volts: _____ Hertz: 50 Hz Phase: 3
 Efficiency: IE1 IE2 IE3

MAXIMUM PUMP OPERATING CONDITIONS

PN 16

12 bars at 65°C (175 psig at 150°F)
 10 bars at 121°C (140 psig at 250°F)

PN 25

20 bars at 65°C (300 psig at 150°F)
 17 bars at 121°C (250 psig at 250°F)

- Tolerance of ±3 mm (±0.125") should be used
- For exact installation, data please write factory for certified dimensions
- Pump equipped with casing drain plug and ¼" NPT suction and discharge gauge ports.
- See performance curves on page 3

OPTIONAL EQUIPMENT

FLUID TYPE	ALL GLYCOLS > 30% WT CONC		ALL OTHER NON-POTABLE FLUIDS		POTABLE (DRINKING) WATER	
Temperature	up to 93°C (200°F)	over 93°C (200°F)	up to 93°C (200°F)	over 93°C (200°F)	up to 93°C (200°F)	over 93°C (200°F)
Rotating face	Silicone carbide		Resin bonded carbon	Antimony loaded carbon	Resin bonded carbon	
Seat elastomer	EPDM (L-cup)	EPDM (O-ring)	EPDM (L-cup)	EPDM (O-ring)	EPDM (L-cup)	EPDM (O-ring)
Material code	SCSc L EPSS 2A	SCSc O EPSS 2A	C-Sc L EPSS 2A	ACSc O EPSS 2A	C-Sc L EPSS 2A	C-Sc O EPSS 2A

MOTOR	KILOWATT @ RPM		FULL LOAD CURRENT (A)	STARTING CURRENT (A)		DIMENSIONS mm (inches)			WEIGHT kg (lbs)
	3000	1500		STAR DELTA (SD)	DIRECT ON LINE (DOL)	E	P	XY	
80	—	0.55	1.3	—	5.5	123 (4.84)	170 (6.69)	415 (16.35)	53.0 (117)
80	1.1	—	2.41	—	16.1	123 (4.84)	170 (6.69)	415 (16.35)	57.0 (126)
90S	1.5	—	3.28	—	19.7	133 (5.24)	190 (7.48)	368 (14.50)	59.0 (130)
90L	2.2	—	4.75	—	29.9	133 (5.24)	190 (7.48)	415 (16.35)	63.0 (139)

PUMP DIMENSIONS

mm (inches)

B	C	D	S	T
96 (3.78)	98 (3.86)	184 (7.25)	178 (7.01)	108 (4.25)

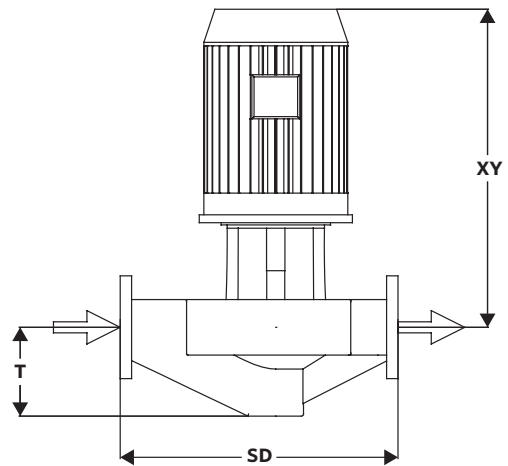
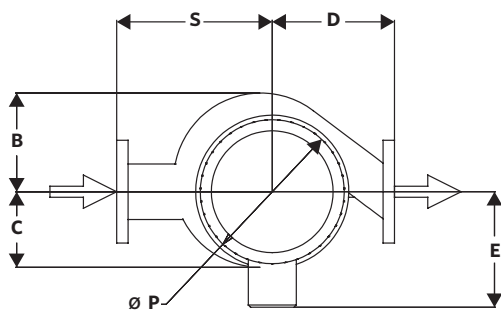

SERIES 4380 PERFORMANCE CURVES

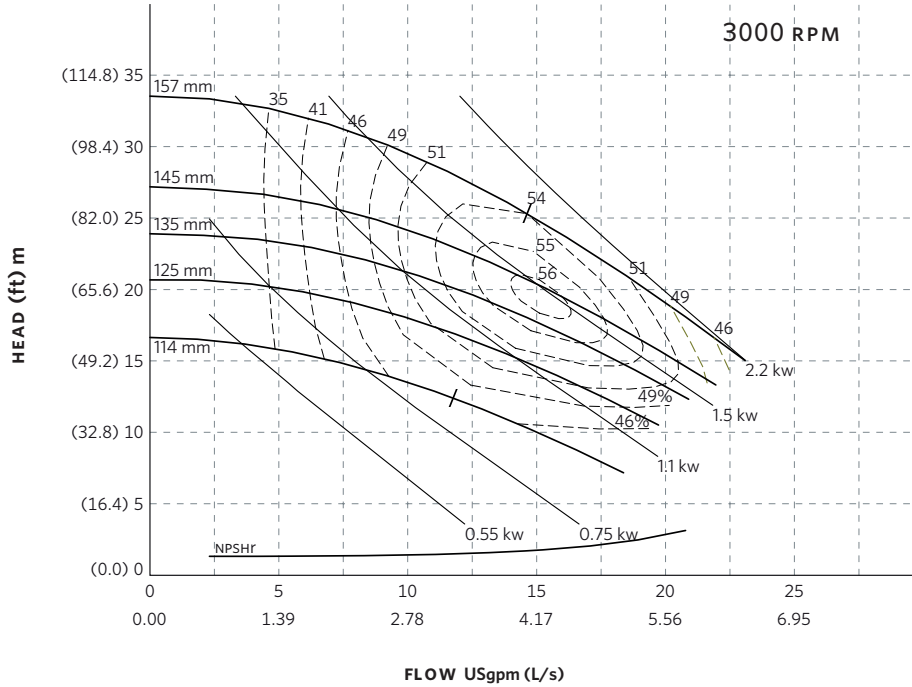

Curve number
PT13-3-0-3000

Series
4300
4380

Size
40-150A

RPM
3000

BHP based on shown
Fluid's sp. gr.

Availability
4300 all ratings
4380 all ratings

Performance
guaranteed only
at operating point
indicated

Curve shown for
clear, cold water
- SP. GR. 1.000

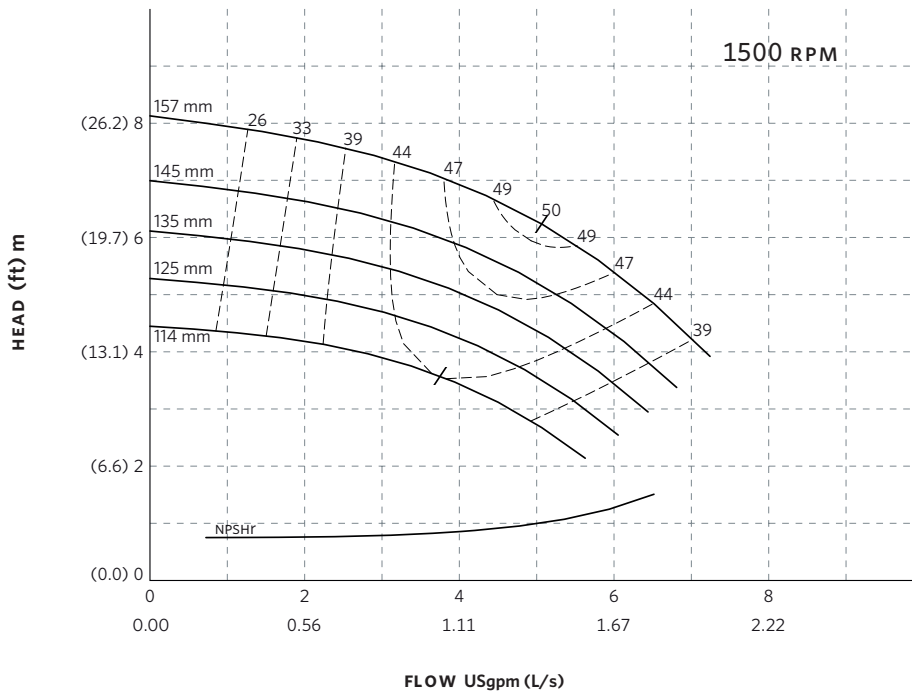

Curve number
PT12-1-0-1500

Series
4300
4380

Size
40-150A

RPM
1500

BHP based on shown
Fluid's sp. gr.

Availability
4300 all ratings
4380 all ratings

Performance
guaranteed only
at operating point
indicated

Curve shown for
clear, cold water
- SP. GR. 1.000

Performance curves are for reference only.
Confirm current performance data with Armstrong ACE Online selection software.

TORONTO

23 BERTRAND AVENUE
TORONTO, ONTARIO
CANADA
M1L 2P3
+1 416 755 2291

BUFFALO

93 EAST AVENUE
NORTH TONAWANDA, NEW YORK
U.S.A.
14120-6594
+1 716 693 8813

BIRMINGHAM

HEYWOOD WHARF, MUCKLOW HILL
HALESOWEN, WEST MIDLANDS
UNITED KINGDOM
B62 8DJ
+44 (0) 8444 145 145

MANCHESTER

WOLVERTON STREET
MANCHESTER
UNITED KINGDOM
M11 2ET
+44 (0) 8444 145 145

BANGALORE

#59, FIRST FLOOR, 3RD MAIN
MARGOSA ROAD, MALLESWARAM
BANGALORE, INDIA
560 003
+91 (0) 80 4906 3555

SHANGHAI

NO. 1619 HU HANG ROAD, XI DU TOWNSHIP
FENG XIAN DISTRICT, SHANGHAI
P.R.C.
201401
+86 21 3756 6696

SÃO PAULO

RUA JOSÉ SEMIÃO RODRIGUES AGOSTINHO,
1370 GALPÃO 6
EMBU DAS ARTES
SAO PAULO, BRAZIL
+55 11 4781 5500

ARMSTRONG FLUID TECHNOLOGY
ESTABLISHED 1934

ARMSTRONGFLUIDTECHNOLOGY.COM

**MAKING
ENERGY
MAKE
SENSE™**