

Series 4300 Vertical In-Line 50Hz (IEC / DIN)

125-290A (5x5x11.5)

SUBMITTAL

JOB: _____	REPRESENTATIVE: _____
_____	_____
ENGINEER: _____	ORDER NO: _____ DATE: _____
CONTRACTOR: _____	SUBMITTED BY: _____ DATE: _____
_____	APPROVED BY: _____ DATE: _____

PUMP DESIGN DATA			
No. of Pumps:			
Tag:			
Capacity:	m ³ /h (l/s)	Head:	m (ft)
Liquid:	Viscosity:		
Temperature:	°C (°F)	Specific Gravity:	

MOTOR DESIGN DATA			
kW:			RPM:
Frame Size:	Enclosure:		
Volts:	Hertz: 50 Hz	Phase:	
Efficiency:	<input type="checkbox"/> IE 1 (NON EU ONLY) <input type="checkbox"/> IE 2 <input type="checkbox"/> IE 3		
Flange Size:	Suction: 125 mm (5")	Discharge: 125 mm (5")	

MATERIALS OF CONSTRUCTIONS				
ANSI Flange Rating	PN 16		PN 25	
Construction	<input type="checkbox"/> BF	<input type="checkbox"/> AI	<input type="checkbox"/> DBF	<input type="checkbox"/> DI
Casing	Cast iron	Cast iron	Ductile iron	Ductile iron
Impeller	Bronze	Cast iron	Bronze	Cast iron
Flush line	Braided Stainless Steel			
Pump shaft	416 Stainless Steel			
Coupling	High Tensile Aluminum			
Gasket	Confined Fiber			

MECHANICAL SEAL DESIGN DATA
See File No. 43.50 for standard mechanical seal details as indicated below
Armstrong Seal Reference Number
<input type="checkbox"/> C1 (a) Other: _____

SEAL DATA OPTIONS

OPTIONAL EQUIPMENT
SEE FILE NO. 43.50 FOR ENVIRONMENTAL ACCESSORIES

MAXIMUM PUMP OPERATING CONDITIONS	
PN 16	PN 25
12 BAR at 60°C (175 PSI at 140°F)	25 BAR at 38°C (363 PSI at 100°F)
7 BAR at 149°C (100 PSI at 300°F)	19 BAR at 149°C (275 PSI at 300°F)
SEE FILE NO. 43.50 FOR MAXIMUM SEAL OPERATING CONDITIONS	

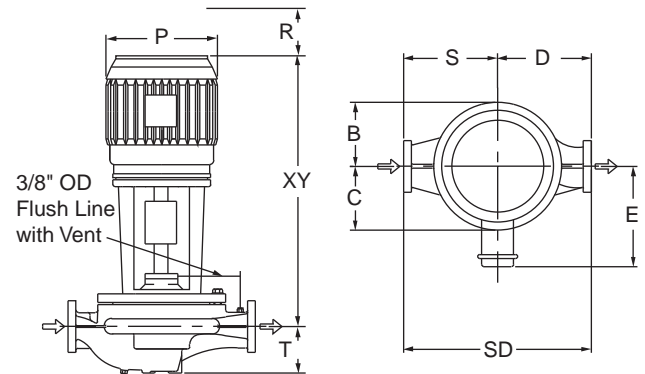

PUMP DIMENSIONS mm (in)						
B	C	D	S	SD	T	
231 (9.09)	205 (8.09)	349 (13.75)	438 (17.25)	787 (31.00)	226 (8.88)	

- Coupling Guard (Not Shown) is supplied.
- Tolerance of ±3 mm (+0.125") should be used.
- For exact installation data please write factory for certified Dimensions.
- See Performance curves on page 2.
- Pump equipped with casing drain plug and 1/4" NPT Suction and Discharge gauge ports

MOTOR kW		FRAME	FULL LOAD CURRENT (A)	STARTING CURRENT (A)		DIMENSIONS mm (in)				ASSEMBLY WEIGHT
3000RPM	1500RPM			STAR DELTA (SD)	DIRECT ON LINE (DOL)	E	P	R	XY	kg (lb)
- - -	4	112M	8.4	18.5	58.9	148 (5.83)	222 (8.74)	200 (7.87)	660 (25.98)	219.0 (483)
- - -	5.5	132s	10.9	24.0	81.8	175 (6.89)	280 (11.02)	250 (9.84)	699 (27.52)	235.0 (518)
- - -	7.5	132M	14.9	32.8	111.8	175 (6.89)	280 (11.02)	250 (9.84)	722 (28.43)	246.0 (542)
- - -	11	160M	21.9	50.4	168.6	208 (8.19)	315 (12.40)	250 (9.84)	831 (32.72)	348.0 (767)
37	- - -	200L	68.7	171.8	535.9	275 (10.83)	390 (15.35)	375 (14.76)	1103 (43.43)	492.0 (1085)
45	- - -	225M	81.5	179.3	570.5	392 (15.43)	468 (18.43)	375 (14.76)	1133 (44.61)	567.0 (1250)
55	- - -	250M	99.2	218.2	694.4	418 (16.46)	510 (20.08)	375 (14.76)	1214 (47.80)	642.0 (1415)
75	- - -	280s	135	324.0	1012.5	465 (18.31)	586 (23.07)	375 (14.76)	1350 (53.15)	792.0 (1746)
90	- - -	280M	161	386.4	1207.5	465 (18.31)	586 (23.07)	375 (14.76)	1350 (53.15)	842.0 (1856)

PERFORMANCE CURVES

Performance Guaranteed Only At Operating Point Indicated
Curve Shown for Clear, Cold water - SP. GR. 1.0

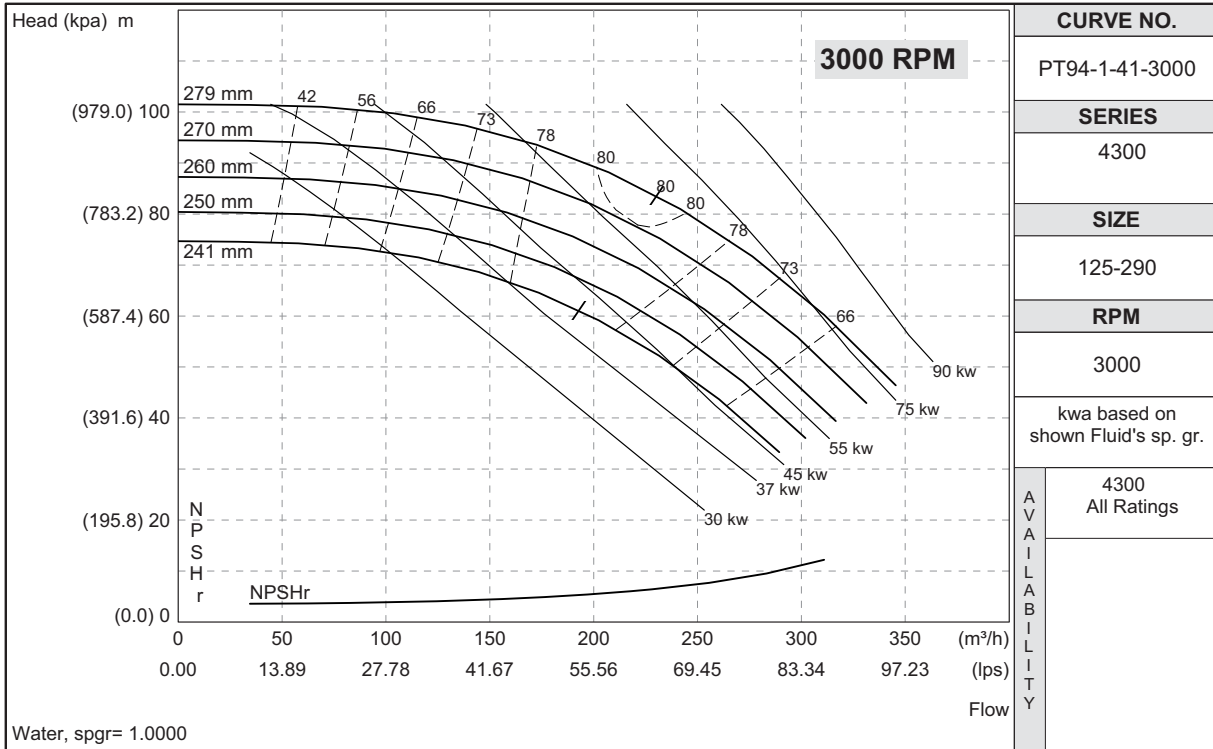

CURVE NO.	PT94-1-41-3000
SERIES	4300
SIZE	125-290
RPM	3000
kwa based on shown Fluid's sp. gr.	
AVAILABILITY	4300 All Ratings

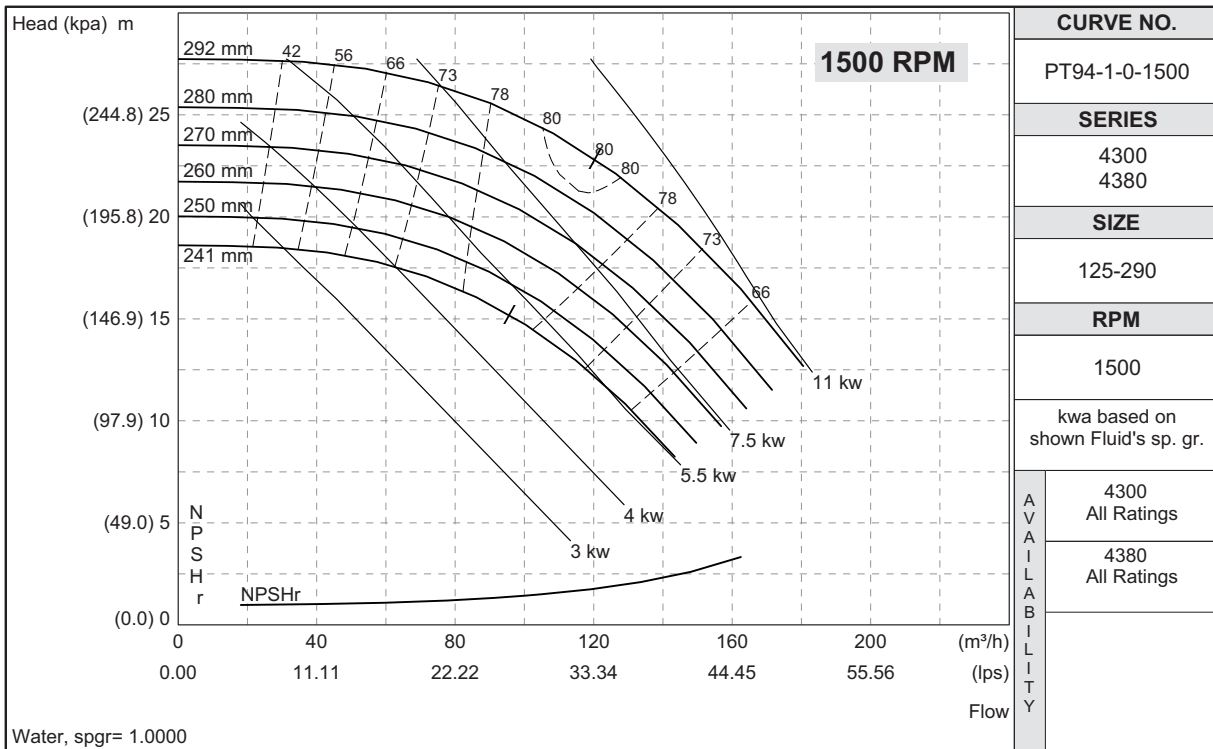

CURVE NO.	PT94-1-0-1500
SERIES	4300 4380
SIZE	125-290
RPM	1500
kwa based on shown Fluid's sp. gr.	
AVAILABILITY	4300 All Ratings
	4380 All Ratings

ARMSTRONG INTEGRATED LIMITED
Wenlock Way
Manchester
United Kingdom, M12 5JL
T +44 (0) 8444 145 145
F +44 (0) 8444 145 146

S. A. ARMSTRONG LIMITED
23 Bertrand Avenue
Toronto, Ontario
Canada, M1L 2P3
T 416 755 2291
F 416 759 9101



© S.A. Armstrong Limited 2011