

SERIES 4280 | END SUCTION MOTOR MOUNTED CLOSED-COUPLED | 4 × 3 × 8 | SUBMITTAL

File No: 42.63
Date: DECEMBER 4, 2014
Supersedes: 42.63
Date: SEPTEMBER 10, 2012

Job: _____ Representative: _____
 _____ Order no: _____ Date: _____
 Engineer: _____ Submitted by: _____ Date: _____
 Contractor: _____ Approved by: _____ Date: _____

PUMP DESIGN DATA

No. of pumps: _____ Tag: _____
 Capacity: _____ USgpm (L/s) Head: _____ ft (m)
 Liquid: _____ Viscosity: _____
 Temperature: _____ °F (°C) Specific gravity: _____
 Suction: 4" (100mm) Flanged
 Discharge: 3" (75mm) Flanged

MATERIALS OF CONSTRUCTION

ANSI FLANGE RATING	ANSI 125	ANSI 250
Construction	<input type="checkbox"/> BF	<input type="checkbox"/> DBF
Casing	Cast iron	Ductile iron
Adapter	Cast iron	Ductile iron

Impeller: Bronze

Gasket: Confined non-asbestos fiber

Shaft: Carbon steel

Shaft sleeve: Bronze

MECHANICAL SEAL DATA

Seal type: 2A **Stationary seat:** Silicone carbide
Secondary seal: EPDM **Rotating hardware:** Stainless steel
Spring: Stainless steel

MOTOR DESIGN DATA

HP: _____ RPM: _____ Frame size: _____ Enclosure: _____
 Volts: _____ Hertz: 60 Hz Phase: 3
 Efficiency: Energy EFF 12.11 NEMA premium 12.12

MAXIMUM PUMP OPERATING CONDITIONS

ANSI 125

175 psig at 150°F (12 bars at 65°C)
 140 psig at 250°F (10 bars at 121°C)

ANSI 250

300 psig at 150°F (20 bars at 65°C)
 250 psig at 250°F (17 bars at 121°C)

- Tolerance of ±0.125" (±3 mm) should be used
- See performance curves on page 3
- For exact installation, data please write factory for certified dimensions
- Pump equipped with casing drain plug and ¼" NPT suction and discharge gauge ports

OPTIONAL EQUIPMENT

FLUID TYPE	ALL GLYCOLS > 30% WT CONC		ALL OTHER NON-POTABLE FLUIDS		POTABLE (DRINKING) WATER	
	up to 200°F (93°C)	over 200°F (93°C)	up to 200°F (93°C)	over 200°F (93°C)	up to 200°F (93°C)	over 200°F (93°C)
Rotating face	Silicone carbide		Resin bonded carbon	Antimony loaded carbon	Resin bonded carbon	
Seat elastomer	EPDM (L-cup)	EPDM (O-ring)	EPDM (L-cup)	EPDM (O-ring)	EPDM (L-cup)	EPDM (O-ring)
Material code	SCSC L EPSS 2A	SCSC O EPSS 2A	C-SC L EPSS 2A	ACSC O EPSS 2A	C-SC L EPSS 2A	C-SC O EPSS 2A

MOTOR	HP @ RPM (ODP & TEFC)			MAX. DIMENSIONS INCHES (mm)										ASSEMBLY WEIGHT*	
	3600	1800	1200	A	B	C MAX		D1	D2	E	F	H	N	lbs (kgs)	
FRAME						ODP	TEFC							ODP	TEFC
145JM	—	2	1	7.00 (178)	6.00 (152)	14.00 (356)	16.00 (406)	6.63 (168)	3.50 (89)	2.75 (70)	5.00 (127)	0.35 (9)	6.63 (168)	148 (67.1)	154 (69.9)
182JM	—	3	1.5	9.00 (229)	5.75 (146)	15.00 (381)	17.00 (432)	6.63 (168)	4.50 (114)	3.75 (95)	4.50 (114)	0.41 (10)	7.38 (187)	151 (68.5)	195 (88.5)
184JM	—	5	—	9.00 (229)	6.75 (172)	16.00 (406)	18.00 (457)	6.63 (168)	4.50 (114)	3.75 (95)	5.50 (140)	0.41 (10)	7.38 (187)	166 (75.3)	202 (91.6)
213JP	—	7.5	2	10.50 (267)	7.00 (178)	21.00 (533)	23.00 (584)	6.63 (168)	5.25 (133)	4.25 (108)	5.50 (140)	0.41 (10)	12.13 (308)	184 (83.5)	260 (117.9)
215JP	15	—	—	10.50 (267)	8.50 (216)	23.00 (584)	25.00 (635)	6.63 (168)	5.25 (133)	4.25 (108)	7.00 (178)	0.41 (10)	12.13 (308)	227 (103.0)	357 (161.9)
254JM	20	—	—	12.38 (314)	10.50 (267)	22.00 (559)	24.00 (610)	6.63 (168)	6.25 (159)	5.00 (127)	8.25 (210)	0.53 (13)	9.75 (248)	232 (105.2)	405 (183.7)
256JM	25	—	—	12.38 (314)	12.25 (311)	24.00 (610)	26.00 (660)	6.63 (168)	6.25 (159)	5.00 (127)	10.00 (254)	0.53 (13)	9.75 (248)	364 (165.1)	490 (222.3)
284JM	30	—	—	13.88 (353)	12.25 (311)	24.00 (610)	26.00 (660)	6.63 (168)	7.00 (178)	5.50 (140)	9.50 (241)	0.53 (13)	9.75 (248)	461 (209.1)	520 (235.9)
286JM	40	—	—	13.88 (353)	13.75 (349)	26.00 (660)	27.00 (686)	6.63 (168)	7.00 (178)	5.50 (140)	11.00 (279)	0.53 (13)	9.75 (248)	545 (247.2)	678 (307.5)
324JM	50	—	—	15.88 (403)	13.75 (349)	26.00 (660)	29.00 (737)	6.63 (168)	8.00 (203)	6.25 (159)	10.50 (267)	0.66 (17)	10.25 (260)	627 (284.4)	715 (324.3)

PUMP DIMENSIONS
inches (mm)

X	Y
11.00 (279)	4.00 (102)

*Assembly weight combines pump and motor.

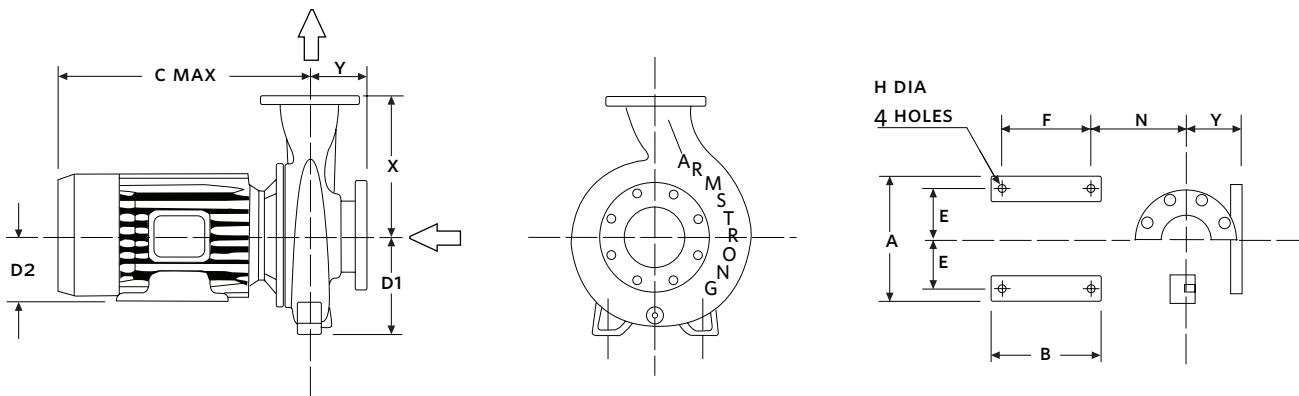

SERIES 4280 PERFORMANCE CURVES

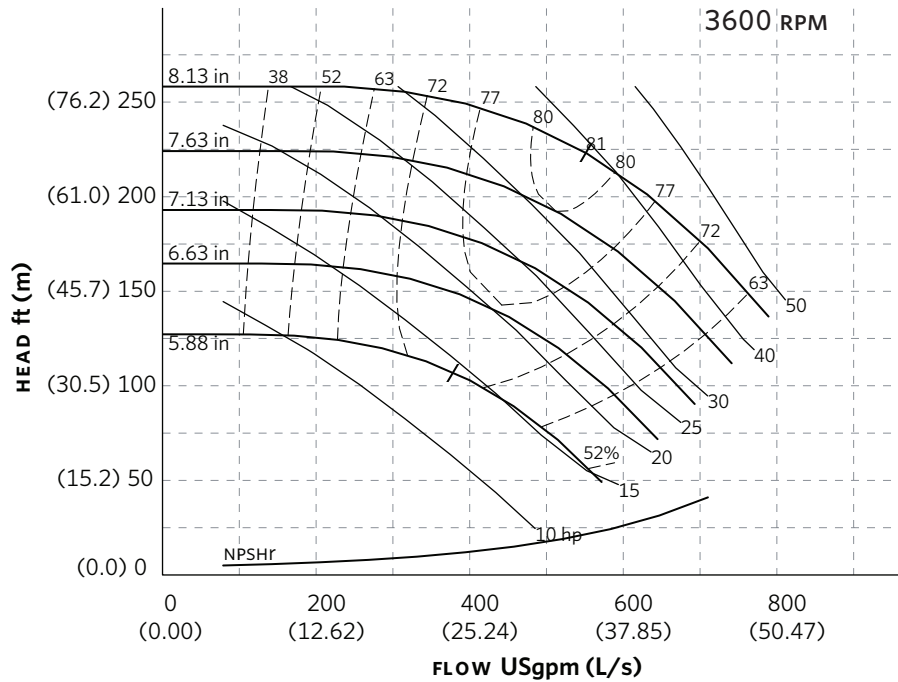

Curve number
PT80-1-0-3600

Series
4030
4280

Size
4 × 3 × 8

RPM
3600

BHP based on shown
Fluid's sp. gr.

Availability
4030 all ratings
4280 all ratings

Performance
guaranteed only
at operating point
indicated.

Curve shown for
clear, cold water
- SP. GR. 1.0000

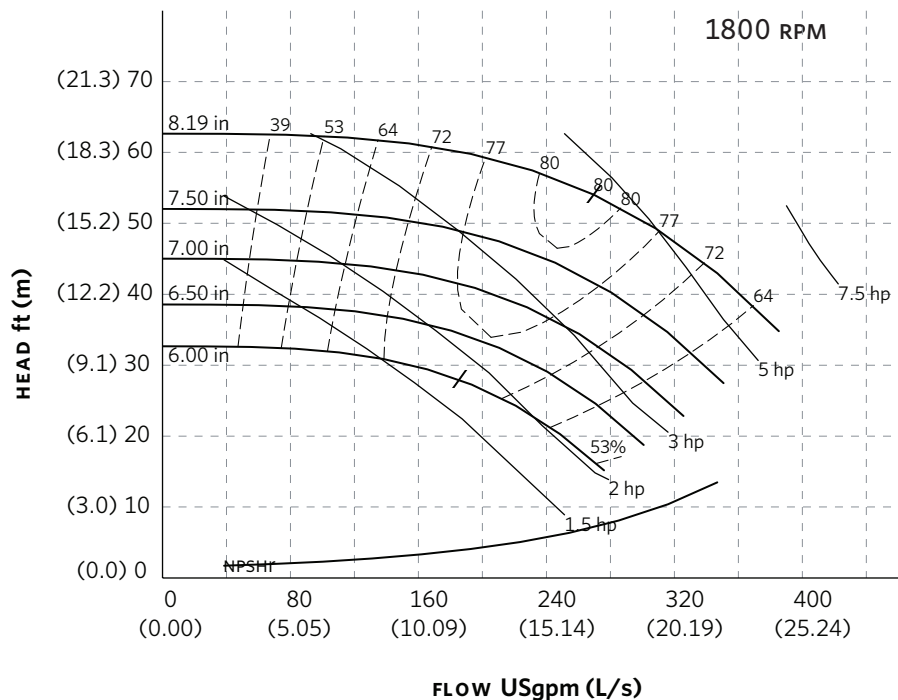

Curve number
PT79-1-0-1800

Series
4030
4280

Size
4 × 3 × 8

RPM
1800

BHP based on shown
Fluid's sp. gr.

Availability
4030 all ratings
4280 all ratings

Performance
guaranteed only
at operating point
indicated.

Curve shown for
clear, cold water
- SP. GR. 1.0000

Performance curves are for reference only.
Confirm current performance data with Armstrong ACE Online selection software.

TORONTO

23 BERTRAND AVENUE
TORONTO, ONTARIO
CANADA
M1L 2P3
+1 416 755 2291

BUFFALO

93 EAST AVENUE
NORTH TONAWANDA, NEW YORK
U.S.A.
14120-6594
+1 716 693 8813

BIRMINGHAM

HEYWOOD WHARF, MUCKLOW HILL
HALESOWEN, WEST MIDLANDS
UNITED KINGDOM
B62 8DJ
+44 (0) 8444 145 145

MANCHESTER

WOLVERTON STREET
MANCHESTER
UNITED KINGDOM
M11 2ET
+44 (0) 8444 145 145

BANGALORE

#59, FIRST FLOOR, 3RD MAIN
MARGOSA ROAD, MALLESWARAM
BANGALORE, INDIA
560 003
+91 (0) 80 4906 3555

SHANGHAI

NO. 1619 HU HANG ROAD, XI DU TOWNSHIP
FENG XIAN DISTRICT, SHANGHAI
P.R.C.
201401
+86 21 3756 6696

**MAKING
ENERGY
MAKE
SENSE™**