

SERIES 4280 | END SUCTION BASE MOUNTED SPLIT COUPLED | 100-290A (5×4×11.5) | SUBMITTAL

File No: 42.76L
Date: MARCH 24, 2016
Supersedes: 42.76L
Date: MARCH 24, 2014

Job: _____ Representative: _____

Order no.: _____ Date: _____

Engineer: _____ Submitted by: _____ Date: _____

Contractor: _____ Approved by: _____ Date: _____

PUMP DESIGN DATA

No. of pumps: _____ Tag: _____
Capacity: _____ m³/h (USgpm) Head: _____ m (ft)
Liquid: _____ Viscosity: _____
Temperature: _____ °C (°F) Specific gravity: _____
Suction: 125mm (5") Flanged
Discharge: 100mm (4") Flanged

MOTOR DESIGN DATA

kW: _____ RPM: _____ Frame size: _____ Enclosure: _____
Volts: _____ Hertz: 50 Hz Phase: 3
Efficiency: IE1 (NON-EU only) IE2 IE3

MATERIALS OF CONSTRUCTION

FLANGE RATING	PN 16	PN 25
Construction	<input type="checkbox"/> BF	<input type="checkbox"/> DBF
Casing	Cast iron	Ductile iron
Adapter	Cast iron	Ductile iron

Impeller: Bronze

Gasket: Confined non-asbestos fiber

Bearing frame: Cast iron

Shaft: Carbon steel

Shaft sleeve: Bronze

MAXIMUM PUMP OPERATING CONDITIONS

PN 16

12 bars at 65°C (175 psig at 150°F)
10 bars at 121°C (140 psig at 250°F)

PN 25

20 bars at 65°C (300 psig at 150°F)
17 bars at 121°C (250 psig at 250°F)

- Tolerance of ±0.125" (±3 mm) should be used
- See performance curves on page 3
- For exact installation, data please write factory for certified dimensions
- Pump equipped with casing drain plug and ¼" NPT suction and discharge gauge ports

MECHANICAL SEAL DATA

Seal type: 2A **Stationary seat:** Silicone carbide
Secondary seal: EPDM **Rotating hardware:** Stainless steel
Spring: Stainless steel

OPTIONAL EQUIPMENT

FLUID TYPE	ALL GLYCOLS > 30% WT CONC		ALL OTHER NON-POTABLE FLUIDS		POTABLE (DRINKING) WATER	
Temperature	up to 93°C (200°F)	over 93°C (200°F)	up to 93°C (200°F)	over 93°C (200°F)	up to 93°C (200°F)	over 93°C (200°F)
Rotating face	Silicone carbide		Resin bonded carbon	Antimony loaded carbon	Resin bonded carbon	
Seat elastomer	EPDM (L-cup)	EPDM (o-ring)	EPDM (L-cup)	EPDM (o-ring)	EPDM (L-cup)	EPDM (o-ring)
Material code	SCSc L EPSS 2A	SCSc O EPSS 2A	C-sc L EPSS 2A	ACSc O EPSS 2A	C-sc L EPSS 2A	C-sc O EPSS 2A

MOTOR	HORSEPOWER @ kW		FULL LOAD CURRENT (A)	STARTING CURRENT (A)		MAX. DIMENSIONS mm (inches)								ASSEMBLY WEIGHT*
	3000	1500		STAR DELTA (SD)	DIRECT ON LINE (DOL)	A	B	C MAX	D1	D2	E	F	N	TEFC kgs (lbs)
132S	—	5.5	10.90	24.0	81.8	276 (10.86)	255 (10.04)	590 (23.21)	254 (10.00)	252 (9.92)	108 (4.25)	225 (8.86)	230 (9.05)	153.7 (339)
132M	—	7.5	14.90	32.8	111.8	276 (10.86)	255 (10.04)	612 (24.11)	254 (10.00)	252 (9.92)	108 (4.25)	225 (8.86)	268 (10.55)	162.7 (359)
160M	—	11	21.90	50.4	168.6	324 (12.76)	340 (13.39)	696 (27.41)	254 (10.00)	255 (10.04)	127 (5.00)	310 (12.20)	307 (12.10)	195.7 (431)
160L	—	15	29.60	68.08	227.92	324 (12.76)	340 (13.39)	766 (30.17)	254 (10.00)	255 (10.04)	127 (5.00)	310 (12.20)	351 (13.83)	215.7 (476)

*Assembly weight combines pump and motor.

PUMP DIMENSIONS

mm (inches)

X	Y
327 (12.88)	152 (6.00)

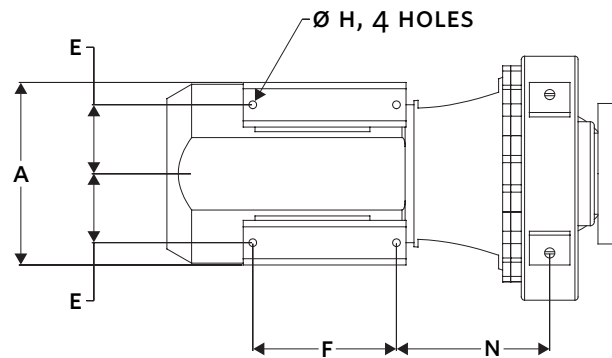
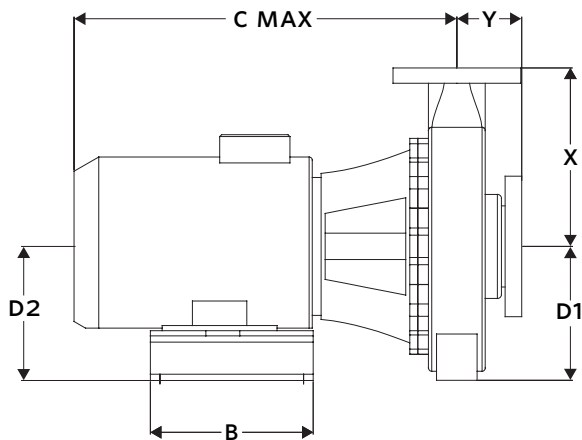

SERIES 4280 PERFORMANCE CURVES

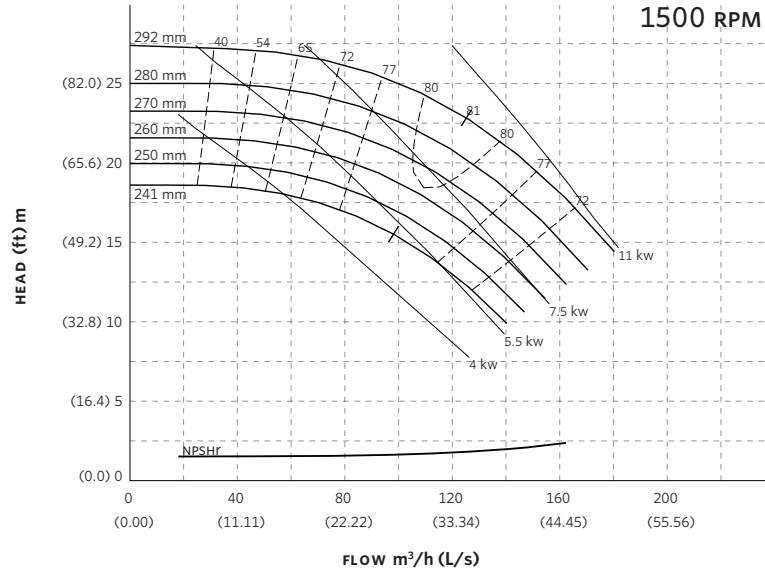

Curve number
PT91-1-0-1500

Series
4030
4280

Size
100-290

RPM
1500

BHP based on shown
Fluid's sp. gr.

Availability
4030 all ratings
4280 all ratings

Performance
guaranteed only
at operating point
indicated.

Curve shown for
clear, cold water
- SP. GR. 1.0000

Performance curves are for reference only.
Confirm current performance data with Armstrong ACE Online selection software.

TORONTO

23 BERTRAND AVENUE
TORONTO, ONTARIO
CANADA
M1L 2P3
+1 416 755 2291

BUFFALO

93 EAST AVENUE
NORTH TONAWANDA, NEW YORK
U.S.A.
14120-6594
+1 716 693 8813

BIRMINGHAM

HEYWOOD WHARF, MUCKLOW HILL
HALESOWEN, WEST MIDLANDS
UNITED KINGDOM
B62 8DJ
+44 (0) 8444 145 145

MANCHESTER

WOLVERTON STREET
MANCHESTER
UNITED KINGDOM
M11 2ET
+44 (0) 8444 145 145

BANGALORE

#59, FIRST FLOOR, 3RD MAIN
MARGOSA ROAD, MALLESWARAM
BANGALORE, INDIA
560 003
+91 (0) 80 4906 3555

SHANGHAI

NO. 1619 HU HANG ROAD, XI DU TOWNSHIP
FENG XIAN DISTRICT, SHANGHAI
P.R.C.
201401
+86 21 3756 6696

SÃO PAULO

RUA JOSÉ SEMIÃO RODRIGUES AGOSTINHO,
1370 GALPÃO 6
EMBU DAS ARTES
SAO PAULO, BRAZIL
+55 11 4781 5500

ARMSTRONG FLUID TECHNOLOGY
ESTABLISHED 1934

ARMSTRONGFLUIDTECHNOLOGY.COM

**MAKING
ENERGY
MAKE
SENSE™**