

4030 END SUCTION BASE MOUNTED | 200-375A (10×8×15) | SUBMITTAL

File No: 40.79IEC
Date: AUGUST 10, 2020
Supersedes: 40.79IEC
Date: APRIL 26, 2016

Job: _____ Representative: _____
 _____ Order no.: _____ Date: _____
 Engineer: _____ Submitted by: _____ Date: _____
 Contractor: _____ Approved by: _____ Date: _____

PUMP DESIGN DATA

No. of pumps: _____ Tag: _____
 Capacity: _____ m³/h (USgpm) Head: _____ m(ft)
 Liquid: _____ Viscosity: _____
 Temperature: _____ °C (°F) Specific gravity: _____
 Suction: 250 mm (10") Flanged
 Discharge: 200 mm (8") Flanged

MATERIALS OF CONSTRUCTION

FLANGE RATING	PN 16	PN 25
Construction	<input type="checkbox"/> BF	<input type="checkbox"/> DBF
Casing	Cast iron	Ductile iron

- Impeller:** Bronze
- Gasket:** Confined non-asbestos fiber
- Bearing frame:** Cast iron
- Anti-friction bearings:** Permanently lubricated
- Shaft:** Carbon steel
- Shaft sleeve:** Stainless steel
- Coupler:** Woods sure flex or equal
- Coupler guard:** Steel OSHA
- Baseplate:** Fabricated steel

MECHANICAL SEAL DATA

- Seal type:** 2A **Stationary seat:** Silicone carbide
- Secondary seal:** EPDM **Rotating hardware:** Stainless steel
- Spring:** Stainless steel

MOTOR DESIGN DATA

kW: _____ RPM: _____
 Frame size: _____ Enclosure: _____
 Volts: _____ Hertz: 50 Hz Phase: 3
 Efficiency: IE1 IE2 IE3

MAXIMUM PUMP OPERATING CONDITIONS

- PN 16**
 16 bars at 49°C (232 psig at 120°F)
 7 bars at 150°C (100 psig at 300°F)
- PN 25**
 25 bars at 65°C (362 psig at 149°F)
 21 bars at 150°C (304 psig at 300°F)

- Tolerance of ±3 mm (±0.125") should be used
- For exact installation, data please write factory for certified dimensions
- Pump equipped with casing drain plug and ¼" NPT suction and discharge gauge ports.
- See performance curves on page 3

OPTIONAL EQUIPMENT

FLUID TYPE	ALL GLYCOLS > 30% WT CONC		ALL OTHER NON-POTABLE FLUIDS		POTABLE (DRINKING) WATER	
	up to 93°C (200°F)	over 93°C (200°F)	up to 93°C (200°F)	over 93°C (200°F)	up to 93°C (200°F)	over 93°C (200°F)
Rotating face	Silicone carbide		Resin bonded carbon	Antimony loaded carbon	Resin bonded carbon	
Seat elastomer	EPDM (L-cup)	EPDM (O-ring)	EPDM (L-cup)	EPDM (O-ring)	EPDM (L-cup)	EPDM (O-ring)
Material code	SCsc L EPSS 2A	SCsc O EPSS 2A	C-SC L EPSS 2A	ACsc O EPSS 2A	C-SC L EPSS 2A	C-SC O EPSS 2A

MOTOR	MOTOR kW @ RPM		FULL LOAD CURRENT (A)	STARTING CURRENT (A)		DIMENSIONS mm(INCHES)								WEIGHT* kg (lbs)
	TEFC			STAR DELTA (SD)	DIRECT ON LINE (DOL)	HA	HB	HC	HD	HE	HF	HG	HL	
FRAME	3000	1500	380-415V											
225S	-	37	69.6	160.1	508.1	635 (25.00)	1676 (66.00)	1522 (59.92)	470 (18.50)	302 (11.88)	1575 (62.00)	102 (4.00)	165 (6.50)	841 (1854)
225M	-	45	83.4	200.2	608.8	635 (25.00)	1676 (66.00)	1550 (61.02)	470 (18.50)	302 (11.88)	1575 (62.00)	102 (4.00)	165 (6.50)	862 (1900)
250M	-	55	101.0	242.4	737.3	635 (25.00)	1676 (66.00)	1631 (64.21)	470 (18.50)	302 (11.88)	1575 (62.00)	102 (4.00)	165 (6.50)	943 (2079)
280S	-	75	139.0	319.7	1014.7	635 (25.00)	1676 (66.00)	1767 (69.56)	470 (18.50)	302 (11.88)	1575 (62.00)	102 (4.00)	165 (6.50)	1138 (2509)
280M	-	90	164.0	393.6	1213.6	635 (25.00)	1676 (66.00)	1767 (69.56)	470 (18.50)	302 (11.88)	1575 (62.00)	102 (4.00)	165 (6.50)	1172 (2584)
315S	-	110	200.0	500.0	1460.0	635 (25.00)	1778 (70.00)	1377 (54.20)	470 (18.50)	302 (11.88)	1676 (66.00)	102 (4.00)	165 (6.50)	1386 (3055)
315M	-	132	240.0	600.0	1752.0	635 (25.00)	1778 (70.00)	1351 (53.18)	470 (18.50)	302 (11.88)	1676 (66.00)	102 (4.00)	165 (6.50)	1452 (3201)

*Assembly weight combines pump and motor.

PUMP DIMENSIONS

mm (inches)

X	Y
483 (19.00)	152 (6.00)

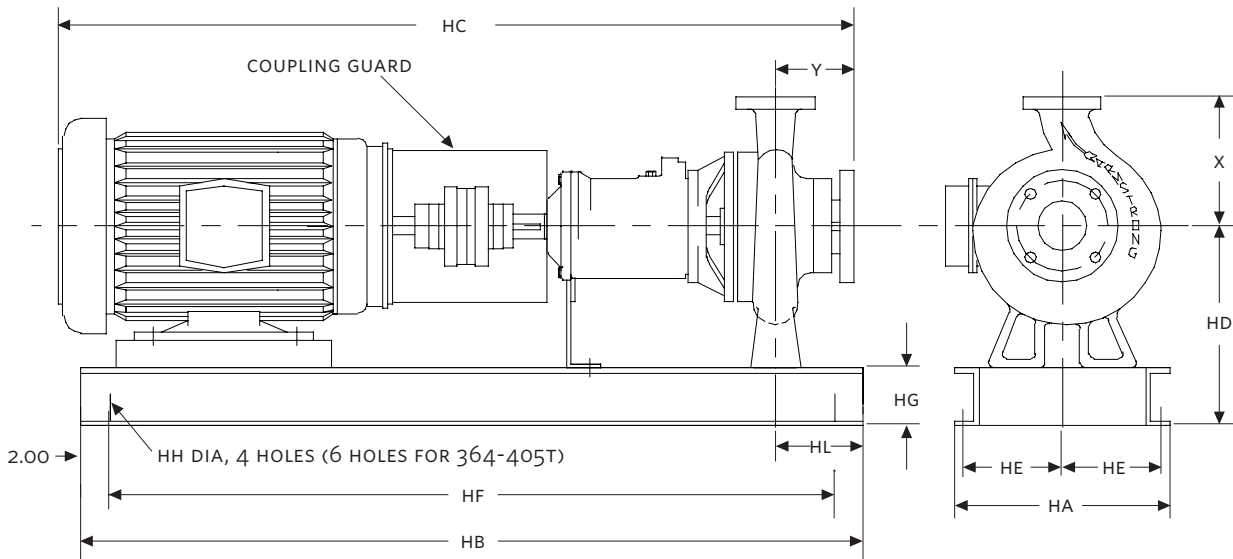

4030 PERFORMANCE CURVES

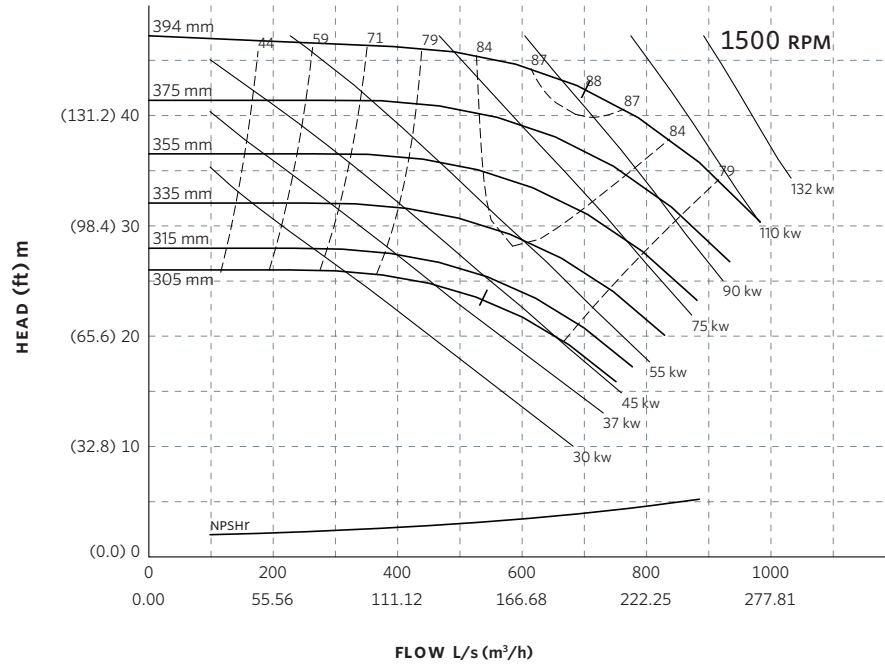

Curve number
PT180-2-0-1500

Series
4030
4280

Size
200-375A

RPM
1500

BHP based on shown
Fluid's sp. gr.

Availability
4030 all ratings
4280 all ratings

Performance
guaranteed only at
operating point
indicated.

Curve shown for
clear, cold water
- SP. GR. 1.000

TORONTO

23 BERTRAND AVENUE
TORONTO, ONTARIO
CANADA, M1L 2P3
+1 416 755 2291

BUFFALO

93 EAST AVENUE
NORTH TONAWANDA, NEW YORK
U.S.A., 14120-6594
+1 716 693 8813

BIRMINGHAM

HEYWOOD WHARF, MUCKLOW HILL
HALESOWEN, WEST MIDLANDS
UNITED KINGDOM, B62 8DJ
+44 8444 145 145

MANCHESTER

WOLVERTON STREET
MANCHESTER
UNITED KINGDOM, M11 2ET
+44 8444 145 145

BANGALORE

#59, FIRST FLOOR, 3RD MAIN
MARGOSA ROAD, MALLESWARAM
BANGALORE, INDIA, 560 003
+91 80 4906 3555

SHANGHAI

UNIT 903, 888 NORTH SICHUAN RD.
HONGKOU DISTRICT, SHANGHAI
CHINA, 200085
+86 21 5237 0909

SÃO PAULO

RUA JOSÉ SEMIÃO RODRIGUES AGOSTINHO,
1370 GALPÃO 6 EMBU DAS ARTES
SAO PAULO, BRAZIL
+55 11 4785 1330

LYON

93 RUE DE LA VILLETTE
LYON, 69003 FRANCE
+33 4 26 83 78 74

DUBAI

JAFZA VIEW 19, OFFICE 402
P.O.BOX 18226 JAFZA,
DUBAI - UNITED ARAB EMIRATES
+971 4 887 6775

MANNHEIM

DYNAMOSTRASSE 13
68165 MANNHEIM
GERMANY
+49 621 3999 9858