

## 4030 END SUCTION BASE MOUNTED | 50-330A (3x2x13) | SUBMITTAL

**File No:** 40.73IEC  
**Date:** AUGUST 10, 2020  
**Supersedes:** 40.73IEC  
**Date:** APRIL 26, 2016

Job: \_\_\_\_\_ Representative: \_\_\_\_\_  
 \_\_\_\_\_ Order no.: \_\_\_\_\_ Date: \_\_\_\_\_  
 Engineer: \_\_\_\_\_ Submitted by: \_\_\_\_\_ Date: \_\_\_\_\_  
 Contractor: \_\_\_\_\_ Approved by: \_\_\_\_\_ Date: \_\_\_\_\_

### PUMP DESIGN DATA

No. of pumps: \_\_\_\_\_ Tag: \_\_\_\_\_  
 Capacity: \_\_\_\_\_ m<sup>3</sup>/h (USgpm) Head: \_\_\_\_\_ m(ft)  
 Liquid: \_\_\_\_\_ Viscosity: \_\_\_\_\_  
 Temperature: \_\_\_\_\_ °C (°F) Specific gravity: \_\_\_\_\_  
 Suction: 75 mm (3") Flanged  
 Discharge: 50 mm (2") Flanged

### MATERIALS OF CONSTRUCTION

FLANGE RATING	PN 16	PN 25
Construction	<input type="checkbox"/> BF	<input type="checkbox"/> DBF
Casing	Cast iron	Ductile iron

**Impeller:** Bronze  
**Gasket:** Confined non-asbestos fiber  
**Bearing frame:** Cast iron  
**Anti-friction bearings:** Permanently lubricated  
**Shaft:** Carbon steel  
**Shaft sleeve:** Stainless steel  
**Coupler:** Woods sure flex or equal  
**Coupler guard:** Steel OSHA  
**Baseplate:** Fabricated steel

### MECHANICAL SEAL DATA

**Seal type:** 2A      **Stationary seat:** Silicone carbide  
**Secondary seal:** EPDM      **Rotating hardware:** Stainless steel  
**Spring:** Stainless steel

### MOTOR DESIGN DATA

kW: \_\_\_\_\_ RPM: \_\_\_\_\_  
 Frame size: \_\_\_\_\_ Enclosure: \_\_\_\_\_  
 Volts: \_\_\_\_\_ Hertz: 50 Hz      Phase: 3  
 Efficiency:  IE1     IE2     IE3

### MAXIMUM PUMP OPERATING CONDITIONS

**PN 16**  
 16 bars at 49°C (232 psig at 120°F)  
 7 bars at 150°C (100 psig at 300°F)

**PN 25**  
 25 bars at 65°C (362 psig at 149°F)  
 21 bars at 150°C (304 psig at 300°F)

- Tolerance of ±3 mm (±0.125") should be used
- For exact installation, data please write factory for certified dimensions
- Pump equipped with casing drain plug and ¼" NPT suction and discharge gauge ports.
- See performance curves on page 3

### OPTIONAL EQUIPMENT

FLUID TYPE	ALL GLYCOLS > 30% WT CONC		ALL OTHER NON-POTABLE FLUIDS		POTABLE (DRINKING) WATER	
	up to 93°C (200°F)	over 93°C (200°F)	up to 93°C (200°F)	over 93°C (200°F)	up to 93°C (200°F)	over 93°C (200°F)
Rotating face	Silicone carbide		Resin bonded carbon	Antimony loaded carbon	Resin bonded carbon	
Seat elastomer	EPDM (L-cup)	EPDM (O-ring)	EPDM (L-cup)	EPDM (O-ring)	EPDM (L-cup)	EPDM (O-ring)
Material code	SCsc L EPSS 2A	SCsc O EPSS 2A	C-SC L EPSS 2A	ACsc O EPSS 2A	C-SC L EPSS 2A	C-SC O EPSS 2A

MOTOR FRAME	MOTOR kW @ RPM		FULL LOAD CURRENT (A) 380-415V	STARTING CURRENT (A)		DIMENSIONS mm(INCHES)								WEIGHT*
	TEFC			STAR DELTA (SD)	DIRECT ON LINE (DOL)	HA	HB	HC	HD	HE	HF	HG	HL	kg (lbs)
	3000	1500												TEFC
100L	-	3	6.4	-	37.1	406 (16.00)	1143 (45.00)	818 (32.21)	330 (13.00)	187 (7.38)	1041 (41.00)	76 (3.00)	114 (4.50)	148.7 (328)
112M	-	4	8.41	18.5	58.9	406 (16.00)	1143 (45.00)	862 (33.95)	330 (13.00)	187 (7.38)	1041 (41.00)	76 (3.00)	114 (4.50)	157.7 (348)
132S	-	5.5	10.90	24.0	81.8	406 (16.00)	1143 (45.00)	935 (36.82)	330 (13.00)	187 (7.38)	1041 (41.00)	76 (3.00)	114 (4.50)	178.7 (394)
132M	-	7.5	14.90	32.8	111.8	406 (16.00)	1143 (45.00)	958 (37.72)	330 (13.00)	187 (7.38)	1041 (41.00)	76 (3.00)	114 (4.50)	187.7 (414)
160M	11	-	21.1	52.8	164.6	406 (16.00)	1143 (45.00)	1082 (42.58)	330 (13.00)	187 (7.38)	1041 (41.00)	76 (3.00)	114 (4.50)	219.7 (484)
160L	18.5	-	34.9	94.2	303.6	483 (19.00)	1219 (48.00)	1097 (43.17)	356 (14.00)	225 (8.88)	1118 (44.00)	102 (4.00)	114 (4.50)	227.7 (502)
180M	22	-	40.9	114.5	368.1	483 (19.00)	1219 (48.00)	1082 (42.58)	356 (14.00)	225 (8.88)	1118 (44.00)	102 (4.00)	114 (4.50)	239.7 (528)
200L	30	-	55.9	139.8	436.0	483 (19.00)	1219 (48.00)	1259 (49.56)	356 (14.00)	225 (8.88)	1118 (44.00)	102 (4.00)	114 (4.50)	279.7 (617)
200L	37	-	68.7	171.8	535.9	483 (19.00)	1219 (48.00)	1259 (49.56)	356 (14.00)	225 (8.88)	1118 (44.00)	102 (4.00)	114 (4.50)	279.7 (617)
225M	45	-	81.5	179.3	570.5	483 (19.00)	1473 (58.00)	1294 (50.94)	356 (14.00)	225 (8.88)	1372 (54.00)	102 (4.00)	114 (4.50)	341.7 (753)
250M	55	-	99.2	218.2	694.4	483 (19.00)	1473 (58.00)	1405 (55.31)	396 (15.60)	225 (8.88)	1372 (54.00)	102 (4.00)	114 (4.50)	370.7 (817)

\*Assembly weight combines pump and motor.

**PUMP DIMENSIONS**

mm (inches)

X	Y
292 (11.50)	102 (4.00)

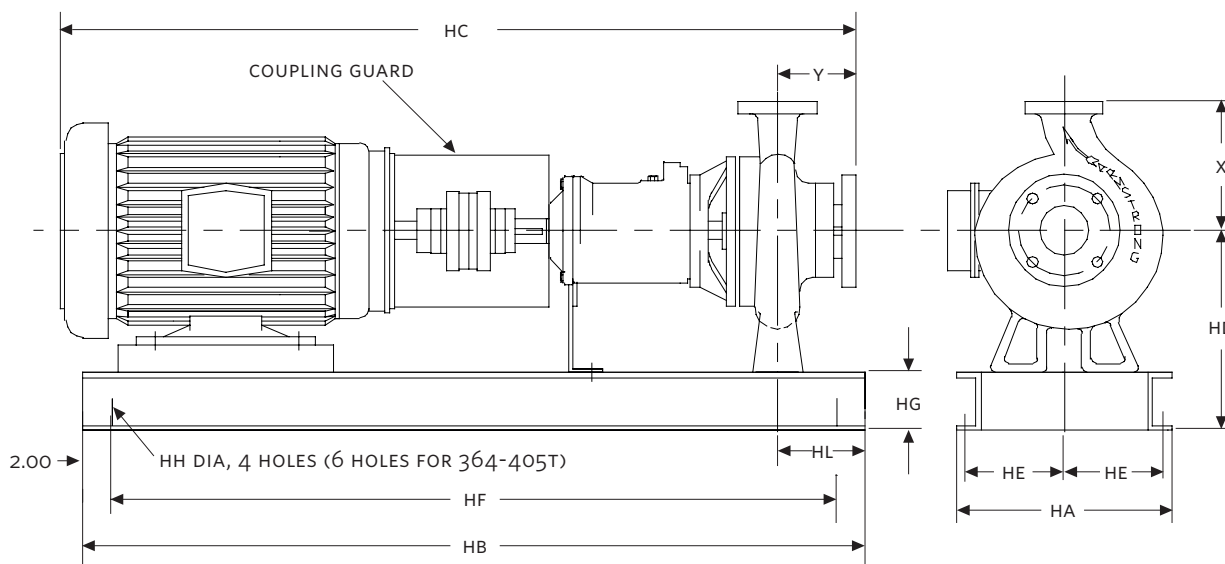

## 4030 PERFORMANCE CURVES

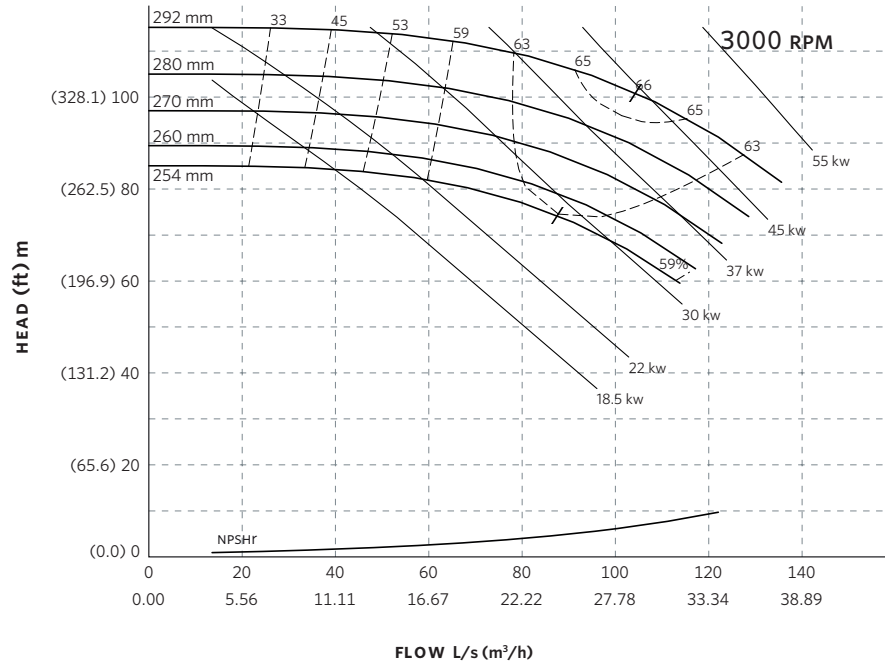

**Curve number**  
PT176-3-0-3000

**Series**  
4030  
4280

**Size**  
50-330A

**RPM**  
3000

BHP based on shown  
Fluid's sp. gr.

**Availability**  
4030 all ratings  
4280 all ratings

Performance  
guaranteed only at  
operating point  
indicated.

Curve shown for  
clear, cold water  
- SP. GR. 1.000

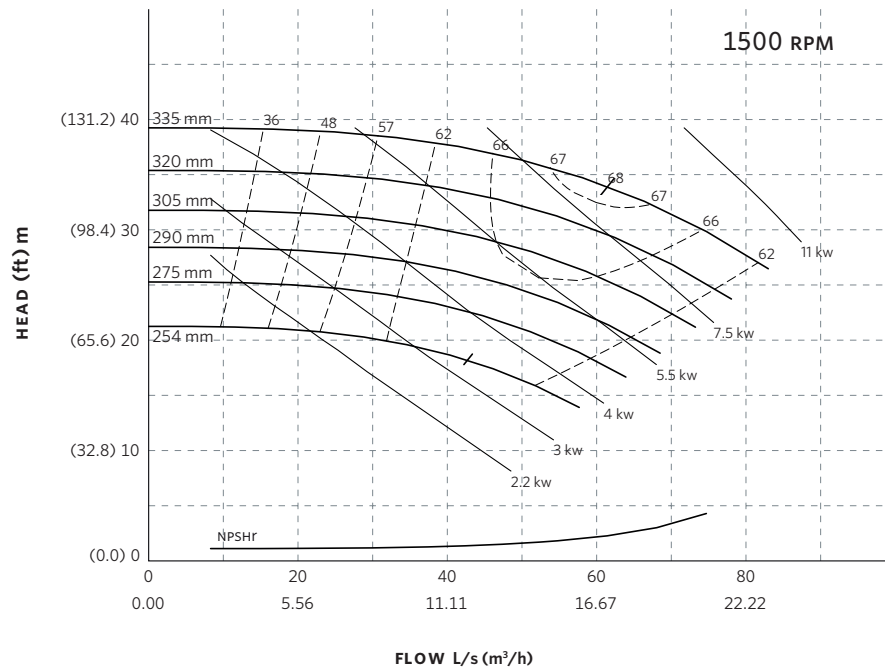

**Curve number**  
PT175-3-0-1500

**Series**  
4030  
4280

**Size**  
50-330A

**RPM**  
1500

kwa based on shown  
Fluid's sp. gr.

**Availability**  
4030 all ratings  
4280 all ratings

Performance  
guaranteed only at  
operating point  
indicated.

Curve shown for  
clear, cold water  
- SP. GR. 1.000

Performance curves are for reference only.  
Confirm current performance data with Armstrong ADEPT Quote or ADEPT Select selection software.

**TORONTO**

23 BERTRAND AVENUE  
TORONTO, ONTARIO  
CANADA, M1L 2P3  
+1 416 755 2291

**BUFFALO**

93 EAST AVENUE  
NORTH TONAWANDA, NEW YORK  
U.S.A., 14120-6594  
+1 716 693 8813

**BIRMINGHAM**

HEYWOOD WHARF, MUCKLOW HILL  
HALESOWEN, WEST MIDLANDS  
UNITED KINGDOM, B62 8DJ  
+44 8444 145 145

**MANCHESTER**

WOLVERTON STREET  
MANCHESTER  
UNITED KINGDOM, M11 2ET  
+44 8444 145 145

**BANGALORE**

#59, FIRST FLOOR, 3RD MAIN  
MARGOSA ROAD, MALLESWARAM  
BANGALORE, INDIA, 560 003  
+91 80 4906 3555

**SHANGHAI**

UNIT 903, 888 NORTH SICHUAN RD.  
HONGKOU DISTRICT, SHANGHAI  
CHINA, 200085  
+86 21 5237 0909

**SÃO PAULO**

RUA JOSÉ SEMIÃO RODRIGUES AGOSTINHO,  
1370 GALPÃO 6 EMBU DAS ARTES  
SAO PAULO, BRAZIL  
+55 11 4785 1330

**LYON**

93 RUE DE LA VILLETTE  
LYON, 69003 FRANCE  
+33 4 26 83 78 74

**DUBAI**

JAFZA VIEW 19, OFFICE 402  
P.O.BOX 18226 JAFZA,  
DUBAI - UNITED ARAB EMIRATES  
+971 4 887 6775

**MANNHEIM**

DYNAMOSTRASSE 13  
68165 MANNHEIM  
GERMANY  
+49 621 3999 9858