

4030 END SUCTION BASE MOUNTED | 40-150A (2x1.5x6) | SUBMITTAL

File No: 40.511EC
Date: AUGUST 10, 2020
Supersedes: 40.511EC
Date: APRIL 26, 2016

Job: _____ Representative: _____
 _____ Order no.: _____ Date: _____
 Engineer: _____ Submitted by: _____ Date: _____
 Contractor: _____ Approved by: _____ Date: _____

PUMP DESIGN DATA

No. of pumps: _____ Tag: _____
 Capacity: _____ m³/h (USgpm) Head: _____ m(ft)
 Liquid: _____ Viscosity: _____
 Temperature: _____ °C (°F) Specific gravity: _____
 Suction: 50 mm (2") Flanged
 Discharge: 40 mm (1.5") Flanged

MATERIALS OF CONSTRUCTION

FLANGE RATING	PN 16	PN 25
Construction	<input type="checkbox"/> BF	<input type="checkbox"/> DBF
Casing	Cast iron	Ductile iron

Impeller: Bronze
Gasket: Confined non-asbestos fiber
Bearing frame: Cast iron
Anti-friction bearings: Permanently lubricated
Shaft: Carbon steel
Shaft sleeve: Stainless steel
Coupler: Woods sure flex or equal
Coupler guard: Steel OSHA
Baseplate: Fabricated steel

MECHANICAL SEAL DATA

Seal type: 2A **Stationary seat:** Silicone carbide
Secondary seal: EPDM **Rotating hardware:** Stainless steel
Spring: Stainless steel

MOTOR DESIGN DATA

kW: _____ RPM: _____
 Frame size: _____ Enclosure: _____
 Volts: _____ Hertz: 50 Hz Phase: 3
 Efficiency: IE1 IE2 IE3

MAXIMUM PUMP OPERATING CONDITIONS

PN 16
 16 bars at 49°C (232 psig at 120°F)
 7 bars at 150°C (100 psig at 300°F)

PN 25
 25 bars at 65°C (362 psig at 149°F)
 21 bars at 150°C (304 psig at 300°F)

- Tolerance of ±3 mm (±0.125") should be used
- For exact installation, data please write factory for certified dimensions
- Pump equipped with casing drain plug and ¼" NPT suction and discharge gauge ports.
- See performance curves on page 3

OPTIONAL EQUIPMENT

FLUID TYPE	ALL GLYCOLS > 30% WT CONC		ALL OTHER NON-POTABLE FLUIDS		POTABLE (DRINKING) WATER	
	up to 93°C (200°F)	over 93°C (200°F)	up to 93°C (200°F)	over 93°C (200°F)	up to 93°C (200°F)	over 93°C (200°F)
Rotating face	Silicone carbide		Resin bonded carbon	Antimony loaded carbon	Resin bonded carbon	
Seat elastomer	EPDM (L-cup)	EPDM (O-ring)	EPDM (L-cup)	EPDM (O-ring)	EPDM (L-cup)	EPDM (O-ring)
Material code	SCsc L EPSS 2A	SCsc O EPSS 2A	C-SC L EPSS 2A	ACsc O EPSS 2A	C-SC L EPSS 2A	C-SC O EPSS 2A

MOTOR	MOTOR kW @ RPM		FULL LOAD CURRENT (A)	STARTING CURRENT (A)		DIMENSIONS mm(INCHES)								WEIGHT* kg (lbs)
	TEFC			STAR DELTA	DIRECT ON LINE	HA	HB	HC	HD	HE	HF	HG	HL	
FRAME	3000 1500		380-415V	(SD)	(DOL)									TEFC
	80	-		0.55	1.3	-	5.5	356 (14.00)	762 (30.00)	689 (27.11)	210 (8.25)	162 (6.38)	660 (26.00)	76 (3.00)
80	-	0.75	1.68	-	7.4	356 (14.00)	762 (30.00)	689 (27.11)	210 (8.25)	162 (6.38)	660 (26.00)	76 (3.00)	114 (4.50)	51.5 (114)
80	1.1	-	2.41	-	16.1	356 (14.00)	762 (30.00)	689 (27.11)	210 (8.25)	162 (6.38)	660 (26.00)	76 (3.00)	114 (4.50)	52.0 (115)
90S	1.5	-	3.28	-	19.7	356 (14.00)	762 (30.00)	650 (25.58)	210 (8.25)	162 (6.38)	660 (26.00)	76 (3.00)	114 (4.50)	55.5 (122)
90L	2.2	-	4.8	-	29.9	356 (14.00)	762 (30.00)	697 (27.43)	210 (8.25)	162 (6.38)	660 (26.00)	76 (3.00)	114 (4.50)	59.0 (130)
100L	3	-	6.1	-	47.8	356 (14.00)	838 (33.00)	738 (29.07)	210 (8.25)	162 (6.38)	737 (29.00)	76 (3.00)	114 (4.50)	66.5 (147)
112M	4	-	8.0	22.4	62.4	356 (14.00)	838 (33.00)	782 (30.80)	210 (8.25)	162 (6.38)	737 (29.00)	76 (3.00)	114 (4.50)	76.0 (168)
132S	5.5	-	10.8	25.9	88.6	356 (14.00)	838 (33.00)	855 (33.67)	235 (9.25)	162 (6.38)	737 (29.00)	76 (3.00)	114 (4.50)	98.0 (216)

*Assembly weight combines pump and motor.

PUMP DIMENSIONS

mm (inches)

X	Y
165 (6.50)	102 (4.00)

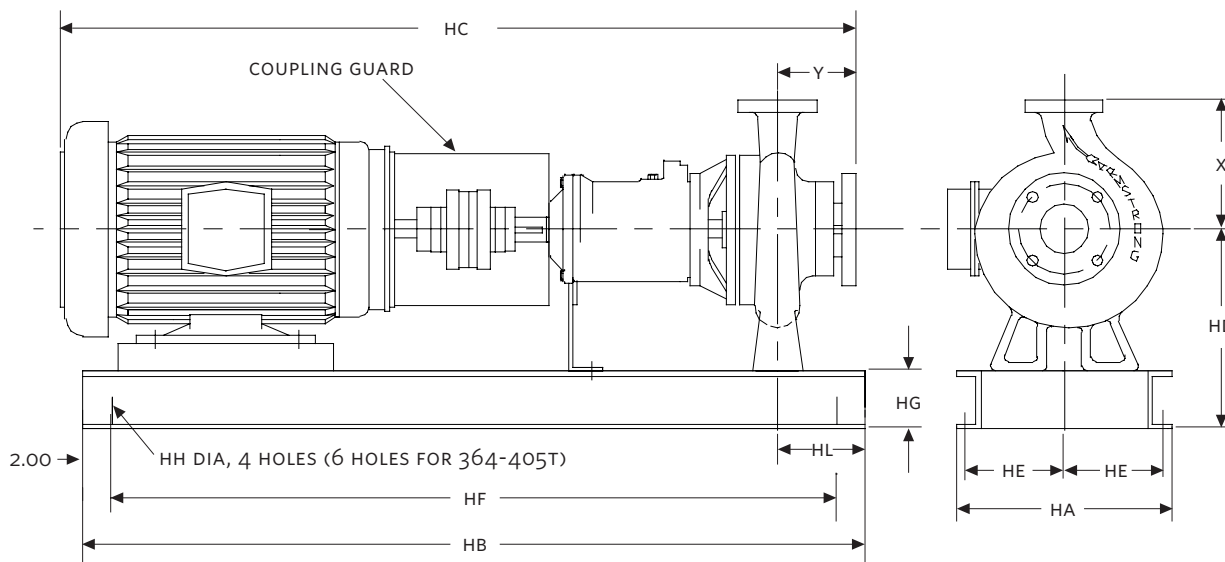

4030 PERFORMANCE CURVES

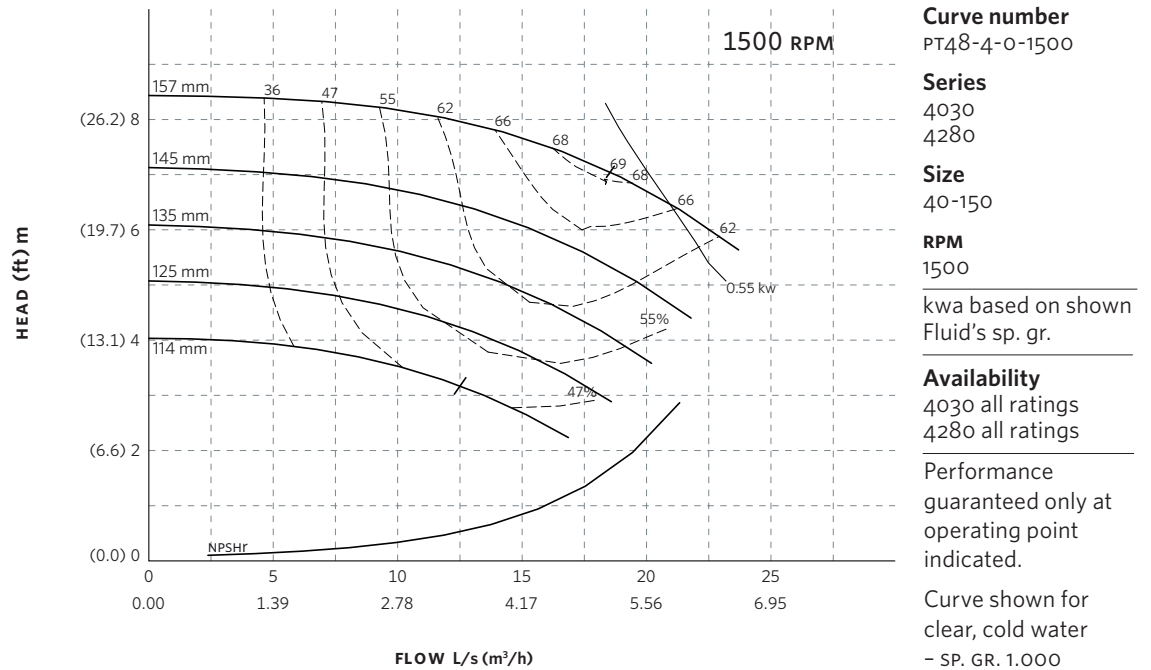
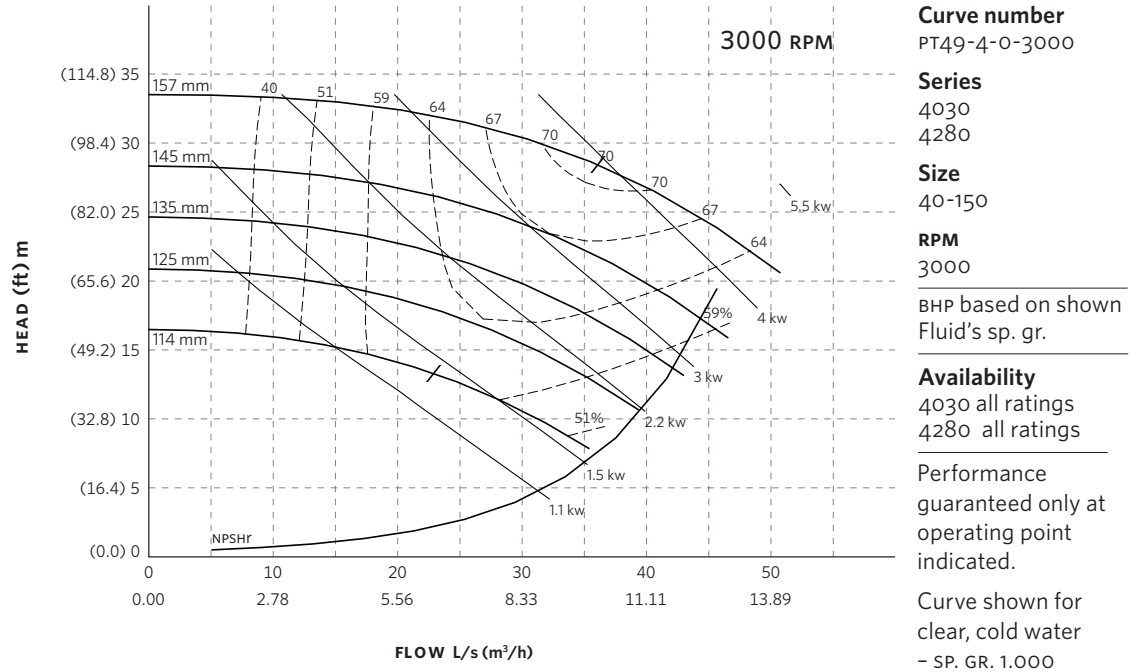

Performance curves are for reference only.
Confirm current performance data with Armstrong ADEPT Quote or ADEPT Select selection software.

TORONTO

23 BERTRAND AVENUE
TORONTO, ONTARIO
CANADA, M1L 2P3
+1 416 755 2291

BUFFALO

93 EAST AVENUE
NORTH TONAWANDA, NEW YORK
U.S.A., 14120-6594
+1 716 693 8813

BIRMINGHAM

HEYWOOD WHARF, MUCKLOW HILL
HALESOWEN, WEST MIDLANDS
UNITED KINGDOM, B62 8DJ
+44 8444 145 145

MANCHESTER

WOLVERTON STREET
MANCHESTER
UNITED KINGDOM, M11 2ET
+44 8444 145 145

BANGALORE

#59, FIRST FLOOR, 3RD MAIN
MARGOSA ROAD, MALLESWARAM
BANGALORE, INDIA, 560 003
+91 80 4906 3555

SHANGHAI

UNIT 903, 888 NORTH SICHUAN RD.
HONGKOU DISTRICT, SHANGHAI
CHINA, 200085
+86 21 5237 0909

SÃO PAULO

RUA JOSÉ SEMIÃO RODRIGUES AGOSTINHO,
1370 GALPÃO 6 EMBU DAS ARTES
SAO PAULO, BRAZIL
+55 11 4785 1330

LYON

93 RUE DE LA VILLETTE
LYON, 69003 FRANCE
+33 4 26 83 78 74

DUBAI

JAFZA VIEW 19, OFFICE 402
P.O.BOX 18226 JAFZA,
DUBAI - UNITED ARAB EMIRATES
+971 4 887 6775

MANNHEIM

DYNAMOSTRASSE 13
68165 MANNHEIM
GERMANY
+49 621 3999 9858