

SERIES 4030 | END SUCTION BASE MOUNTED SPLIT COUPLED | 4 × 3 × 8 | SUBMITTAL

File No: 40.58
Date: NOV. 26, 2014
Supersedes: 40.58
Date: OCT. 15, 2013

Job: _____ Representative: _____

Order no.: _____ Date: _____

Engineer: _____ Submitted by: _____ Date: _____

Contractor: _____ Approved by: _____ Date: _____

PUMP DESIGN DATA

No. of pumps: _____ Tag: _____
Capacity: _____ USgpm (L/s) Head: _____ ft (m)
Liquid: _____ Viscosity: _____
Temperature: _____ °F (°C) Specific gravity: _____
Suction: 4" (100mm) Flanged
Discharge: 3" (75mm) Flanged

MATERIALS OF CONSTRUCTION

ANSI FLANGE RATING	ANSI 125	ANSI 250
Construction	<input type="checkbox"/> BF	<input type="checkbox"/> DBF
Casing	Cast iron	Ductile iron

Impeller: Bronze

Gasket: Confined non-asbestos fiber

Bearing frame: Cast iron

Anti-friction bearings: Permanently lubricated

Shaft: Carbon steel

Shaft sleeve: Stainless steel

Coupler: Constant speed: Woods sure-flex or equal
Variable speed: Woods dura-flex or equal

Coupler guard: Steel OSHA

Baseplate: Fabricated steel

MECHANICAL SEAL DATA

Seal type: 2A **Stationary seat:** Silicone carbide
Secondary seal: EPDM **Rotating hardware:** Stainless steel
Spring: Stainless steel

MOTOR DESIGN DATA

HP: _____ RPM: _____ Frame size: _____ Enclosure: _____
Volts: _____ Hertz: 60 Hz Phase: 3
Efficiency*: NEMA premium 12.12 Other _____ %

* Fractional power and frame 56 motors are supplied with the standard efficiency of the manufacturer.

MAXIMUM PUMP OPERATING CONDITIONS

ANSI 125

175 psig at 150°F (12 bars at 65°C)
140 psig at 250°F (10 bars at 121°C)

ANSI 250

300 psig at 150°F (20 bars at 65°C)
250 psig at 250°F (17 bars at 121°C)

- Tolerance of ±0.125" (±3 mm) should be used
- See performance curves on page 3
- For exact installation, data please write factory for certified dimensions
- Pump equipped with casing drain plug and ¼" NPT suction and discharge gauge ports

OPTIONAL EQUIPMENT

FLUID TYPE	ALL GLYCOLS > 30% WT CONC		ALL OTHER NON-POTABLE FLUIDS		POTABLE (DRINKING) WATER	
	up to 200°F (93°C)	over 200°F (93°C)	up to 200°F (93°C)	over 200°F (93°C)	up to 200°F (93°C)	over 200°F (93°C)
Rotating face	Silicone carbide		Resin bonded carbon	Antimony loaded carbon	Resin bonded carbon	
Seat elastomer	EPDM (L-cup)	EPDM (O-ring)	EPDM (L-cup)	EPDM (O-ring)	EPDM (L-cup)	EPDM (O-ring)
Material code	SCSc L EPSS 2A	SCSc O EPSS 2A	C-SC L EPSS 2A	ACSc O EPSS 2A	C-SC L EPSS 2A	C-SC O EPSS 2A

MOTOR FRAME	HORSEPOWER @ RPM				MAX. DIMENSIONS INCHES (mm)											MAX. ASSEMBLY WEIGHT*	
	3600		1800	1200	HA	HB	HC	HD	HE	HF	HG	HH	HL	X	Y	ODP	TEFC
	ODP	TEFC															
56C	—	—	—	0.5	14.00 (356)	30.00 (762)	26.38 (670)	10.25 (260)	6.38 (162)	26.00 (660)	3.00 (76)	0.75 (19)	4.50 (114)	11.00 (279)	4.00 (102)	165 (74.8)	165 (74.8)
143TC	—	—	—	0.75	14.00 (356)	30.00 (762)	28.03 (712)	10.25 (260)	6.38 (162)	26.00 (660)	3.00 (76)	0.75 (19)	4.50 (114)	11.00 (279)	4.00 (102)	170 (77.1)	175 (79.4)
145TC	—	—	2	1	14.00 (356)	30.00 (762)	28.03 (712)	10.25 (260)	6.38 (162)	26.00 (660)	3.00 (76)	0.75 (19)	4.50 (114)	11.00 (279)	4.00 (102)	188 (85.3)	196 (88.9)
182TC	—	—	3	1.5	14.00 (356)	30.00 (762)	30.72 (780)	10.25 (260)	6.38 (162)	26.00 (660)	3.00 (76)	0.75 (19)	4.50 (114)	11.00 (279)	4.00 (102)	208 (94.3)	239 (108.4)
184TC	—	—	5	2	14.00 (356)	30.00 (762)	30.72 (780)	10.25 (260)	6.38 (162)	26.00 (660)	3.00 (76)	0.75 (19)	4.50 (114)	11.00 (279)	4.00 (102)	220 (99.8)	248 (112.5)
213TC	—	—	7.5	—	14.00 (356)	33.00 (838)	34.40 (874)	10.25 (260)	6.38 (162)	29.00 (737)	3.00 (76)	0.75 (19)	4.50 (114)	11.00 (279)	4.00 (102)	255 (115.7)	305 (138.3)
215TC	15	—	—	—	14.00 (356)	33.00 (838)	34.40 (874)	10.25 (260)	6.38 (162)	29.00 (737)	3.00 (76)	0.75 (19)	4.50 (114)	11.00 (279)	4.00 (102)	280 (127.0)	313 (142.0)
254TC	20	15	—	—	16.00 (406)	45.00 (1143)	43.51 (1105)	11.25 (286)	7.38 (187)	41.00 (1041)	3.00 (76)	0.75 (19)	4.50 (114)	11.00 (279)	4.00 (102)	405 (183.7)	420 (190.5)
256TC	25	20	—	—	16.00 (406)	45.00 (1143)	43.51 (1105)	11.25 (286)	7.38 (187)	41.00 (1041)	3.00 (76)	0.75 (19)	4.50 (114)	11.00 (279)	4.00 (102)	460 (208.7)	503 (228.2)
284TSC	30	25	—	—	19.00 (483)	48.00 (1219)	44.63 (1134)	12.25 (311)	8.88 (225)	44.00 (1118)	4.00 (102)	0.75 (19)	4.50 (114)	11.00 (279)	4.00 (102)	563 (255.4)	555 (251.7)
286TSC	40	30	—	—	19.00 (483)	48.00 (1219)	45.41 (1153)	12.25 (311)	8.88 (225)	44.00 (1118)	4.00 (102)	0.75 (19)	4.50 (114)	11.00 (279)	4.00 (102)	647 (293.5)	618 (280.3)
324TSC	50	40	—	—	19.00 (483)	48.00 (1219)	47.92 (1217)	12.25 (311)	8.88 (225)	44.00 (1118)	4.00 (102)	0.75 (19)	4.50 (114)	11.00 (279)	4.00 (102)	750 (340.2)	751 (340.6)
326TSC	—	50	—	—	19.00 (483)	48.00 (1219)	47.92 (1217)	12.25 (311)	8.88 (225)	44.00 (1118)	4.00 (102)	0.75 (19)	4.50 (114)	11.00 (279)	4.00 (102)	—	797 (361.5)

*Assembly weight combines pump and motor.

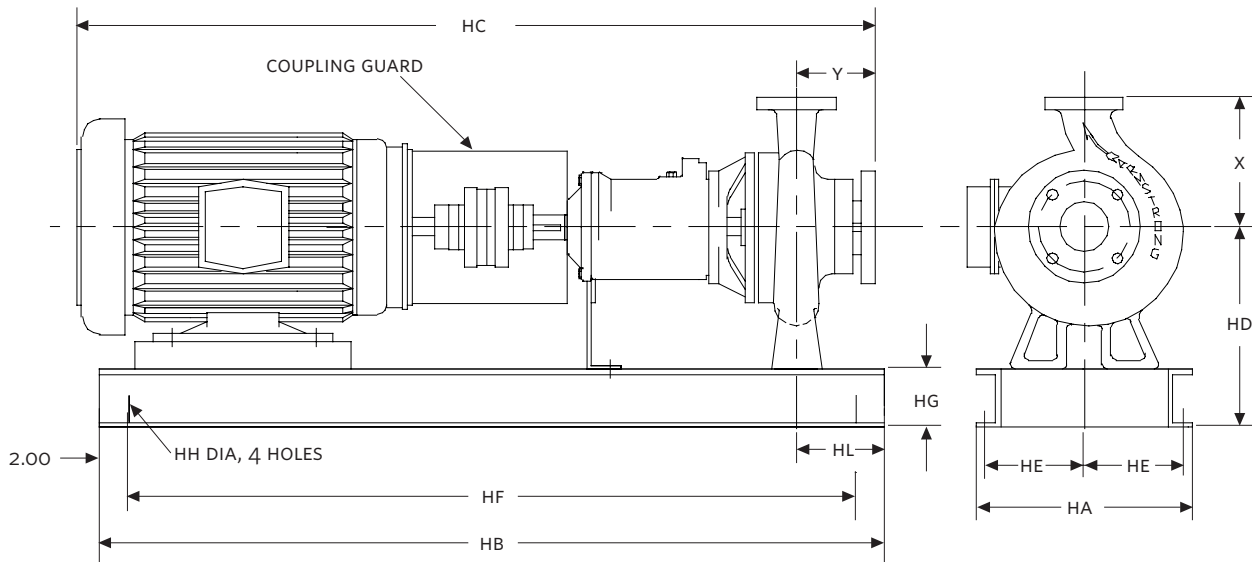

SERIES 4030 PERFORMANCE CURVES

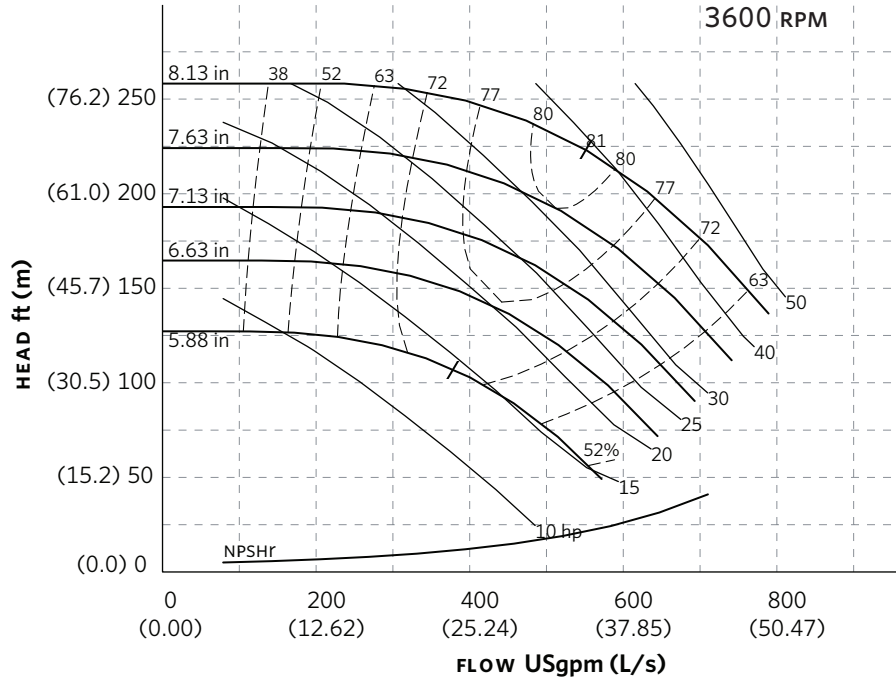

Curve number
PT80-1-0-3600

Series
4030
4280

Size
4 × 3 × 8

RPM
3600

BHP based on shown
Fluid's sp. gr.

Availability
4030 all ratings
4280 all ratings

Performance
guaranteed only
at operating point
indicated.

Curve shown for
clear, cold water
- SP. GR. 1.0000

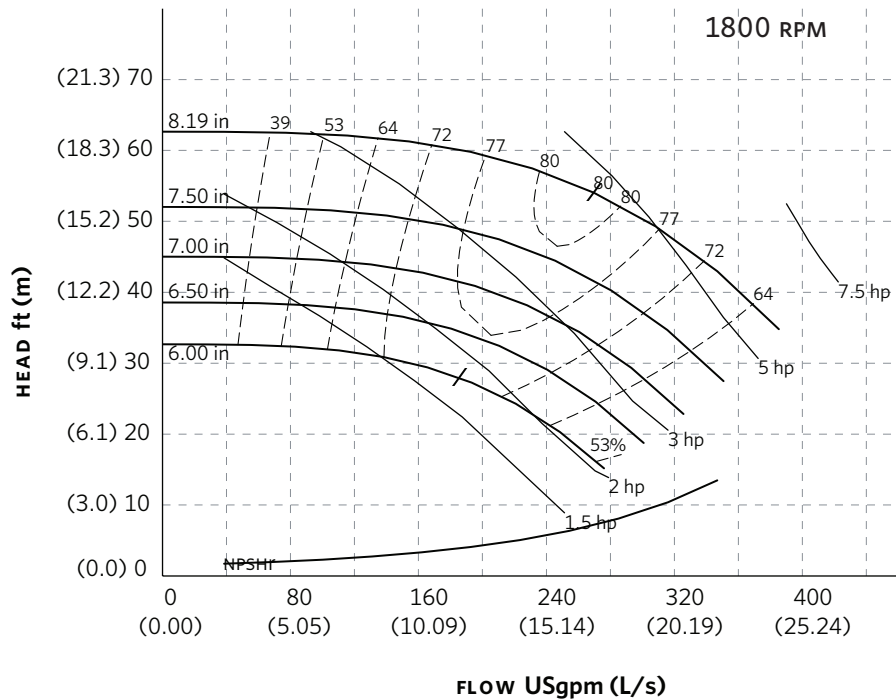

Curve number
PT79-1-0-1800

Series
4030
4280

Size
4 × 3 × 8

RPM
1800

BHP based on shown
Fluid's sp. gr.

Availability
4030 all ratings
4280 all ratings

Performance
guaranteed only
at operating point
indicated.

Curve shown for
clear, cold water
- SP. GR. 1.0000

Performance curves are for reference only.
Confirm current performance data with Armstrong ACE Online selection software.

TORONTO

23 BERTRAND AVENUE
TORONTO, ONTARIO
CANADA
M1L 2P3
+1 416 755 2291

BUFFALO

93 EAST AVENUE
NORTH TONAWANDA, NEW YORK
U.S.A.
14120-6594
+1 716 693 8813

BIRMINGHAM

HEYWOOD WHARF, MUCKLOW HILL
HALESOWEN, WEST MIDLANDS
UNITED KINGDOM
B62 8DJ
+44 (0) 8444 145 145

MANCHESTER

WENLOCK WAY
MANCHESTER
UNITED KINGDOM
M12 5JL
+44 (0) 8444 145 145

BANGALORE

#59, FIRST FLOOR, 3RD MAIN
MARGOSA ROAD, MALLESWARAM
BANGALORE, INDIA
560 003
+91 (0) 80 4906 3555

SHANGHAI

NO. 1619 HU HANG ROAD, XI DU TOWNSHIP
FENG XIAN DISTRICT, SHANGHAI
P.R.C.
201401
+86 21 3756 6696

**MAKING
ENERGY
MAKE
SENSE™**