

TANK ALERT® XT Indoor/Outdoor Alarm

Versatile, indoor or outdoor liquid level alarm system.

This alarm system monitors liquid levels in lift pump chambers, sump pump basins, holding tanks, sewage, agricultural, and other non-potable water applications.

The alarm horn sounds and the red beacon illuminates when a potentially threatening liquid level condition occurs.



FEATURES

- Enclosure meets Type 3R water-tight standards.
- Automatic alarm re-set, horn silence switch, and alarm test switch.
- Alarm horn sounds at 82 decibels at 10 feet (3 meters).
- Alarm system (when installed on separate circuit) operates even if pump circuit fails.
- Complete package includes standard Sensor Float® control switch with 15 feet (4.57 meters) of cable and mounting clamp.
- UL Listed for indoor or outdoor use under UL standard 864.
- CSA Certified.
- Three-year limited warranty.

SPECIFICATIONS

VOLTAGE: 120 VAC, 50/60 Hz, 7 watts max. (alarm condition)

ALARM ENCLOSURE: 6.5 x 4.5 x 3.0 inch (16.51 x 11.43 x 7.62 cm), indoor-outdoor, weatherproof, thermoplastic meets 3R water-tight standards

ALARM HORN: 82 decibels at 10 feet (3 meters), meets Type 3R water-tight standards as installed by factory

ALARM BEACON: meets Type 3R water-tight standards as installed by factory

TEST/SILENCE SWITCH: certified to IP66 and IP68 standards

FLOAT SWITCH: Sensor Float® control switch with mounting clamp

Cable: 15 feet (4.57 meters), flexible 18 gauge, 2 conductor (UL) SJOW, water-resistant (CPE)

Float: 3.38 inch diameter x 4.55 inch long (8.58 cm x 11.56 cm), high impact, corrosion resistant PVC housing for use in sewage and non-potable water up to 140°F (60°C)

Switch: hermetically sealed steel capsule features mercury-to-mercury contacts

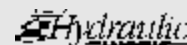

Tank Alert® XT Indoor/Outdoor Alarm Installation Instructions

 <p>WARNING</p>	<p>ELECTRICAL SHOCK HAZARD</p> <p>Disconnect power before installing or servicing this product. A qualified service person must install and service this product according to applicable electrical and plumbing codes.</p>	 <p>WARNING</p>	<p>EXPLOSION OR FIRE HAZARD</p> <p>Do not use this product with flammable liquids. Do not install in hazardous locations as defined by National Electrical Code, ANSI/NFPA 70.</p>
<p>Failure to follow these precautions could result in serious injury or death. Replace product immediately if switch cable becomes damaged or severed. Keep these instructions with warranty after installation. This product must be installed in accordance with National Electric Code, ANSI/NFPA 70 so as to prevent moisture from entering or accumulating within boxes, conduit bodies, fittings, float housing, or cable.</p>			

INSTALLING THE FLOAT SWITCH

- Place the cord into the clamp as shown in Figure A.
- Locate the clamp at the desired activation level and secure the clamp to the discharge pipe as shown in see Figure A. **Note:** Do not install cord under hose clamp.
- Tighten the hose clamp using a screwdriver. Over tightening may result in damage to the plastic clamp. Make sure the float cable is not allowed to touch the excess hose clamp band during operation.
- Wire cable leads directly into control device as shown in Figure B.
- Check installation. Allow system to cycle to insure proper operation. **Note:** All hose clamp components are made of 18-8 stainless steel material. See your SJE-Rhombus supplier for replacements.

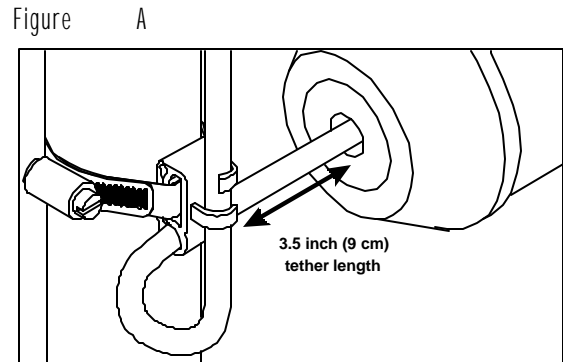

INSTALLING THE ALARM

- Mount alarm box using existing holes in back of box. To ensure water-tight seal, use screws and sealing washers included with alarm.
- Determine "conduit-in" locations on alarm as shown in Figure B. **Note:** When used with a pump application, connect alarm to a circuit separate from the pump circuit. This allows alarm to continue to operate if the pump circuit fails.
- Drill holes for conduit entry, taking care not to damage bosses inside alarm box.
- Attach conduit.

If alarm includes premounted terminal block option, refer now to the Terminal Block Option Wiring Instructions.

- Bring float switch cable through conduit and wire to terminal strip positions F1 and F2 on alarm cover as shown in Figure B.
- Wire power conductors to terminal strip positions L1 (line) and N (neutral) and ground wire to ground termination post as shown in Figure B. **Note:** If terminal block option is used, attach ground wire to left terminal 4 as shown in Figure A of Terminal Block Option Wiring Instructions.
- If remote device is used, connect to terminal strip for optional auxiliary contacts as shown in Figure B.
- Connect wire leads from circuit board to beacon as shown in Figure B.
- Attach alarm box cover using the four pre-installed screws.
- Turn on power.
- Check installation by manually tipping the float. The system should indicate an alarm condition.
- Push silence switch to test silence feature.
- Test unit periodically to insure proper operation.

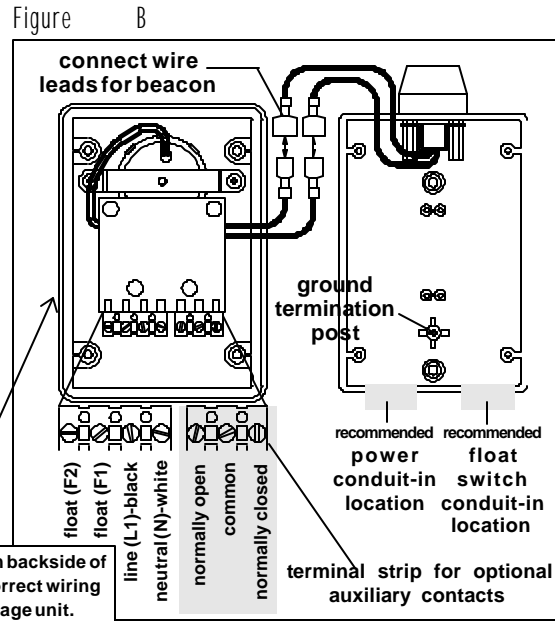

S.A. Armstrong Limited
 23 Bertrand Avenue
 Toronto, Ontario
 Canada, M1L 2P3
 Tel: (416) 755-2291
 Fax: (416) 759-9101
 Visit us at www.armstrongpumps.com

Armstrong Pumps Limited
 Peartree Road, Stanway
 Colchester, Essex
 United Kingdom, C03 5JX
 Tel: 01206-579491
 Fax: 01206-760532



Armstrong Pumps Inc.
 93 East Avenue
 Buffalo, New York
 U.S.A. 14120-6594
 Tel: (716) 693-8813
 Fax: (716) 693-8970

Armstrong Darling Inc.
 2200 Place Transcanadienne
 Montreal, Quebec
 Canada, H9P 2X5
 Tel: (514) 421-2424
 Fax: (514) 421-2436

