

PUMP SIZE	MOTOR KW	FLC AMPS 3x415W	PUMP WEIGHT KGS	SET WEIGHT KGS	VESSEL SIZE LTRS	WORKING PRESSURE MAX BAR	TEST PRESSURE MAX BAR	STARTING CURRENT	L MM	A MM	B MM
SV0402	0.55	1.5	17.5	78	60	2	24	4	559	219	251
SV0403	0.55	1.5	18.5	80	60	2.9	24	4	606	219	251
SV0404	0.75	1.9	21	85	60	3.9	24	6	636	219	251
SV0405	1.1	2.6	22	87	60	4.9	24	6	698	219	251
SV0406	1.1	2.6	22.5	88	60	5.9	24	6	723	219	251
SV0407	1.1	2.6	23	89	60	6.9	24	6	748	219	251
SV0408	1.5	3.6	29.5	102	60	1.8	24	6	783	219	251
SV0409	1.5	3.6	30	103	60	8.8	24	6	808	219	251
SV0411	2.2	5	32	107	60	10.8	24	10	858	219	251
SV0413	2.2	5	33	109	60	12.8	24	10	908	219	251
SV0414	3	6.6	39	121	60	13.8	24	16	983	219	251

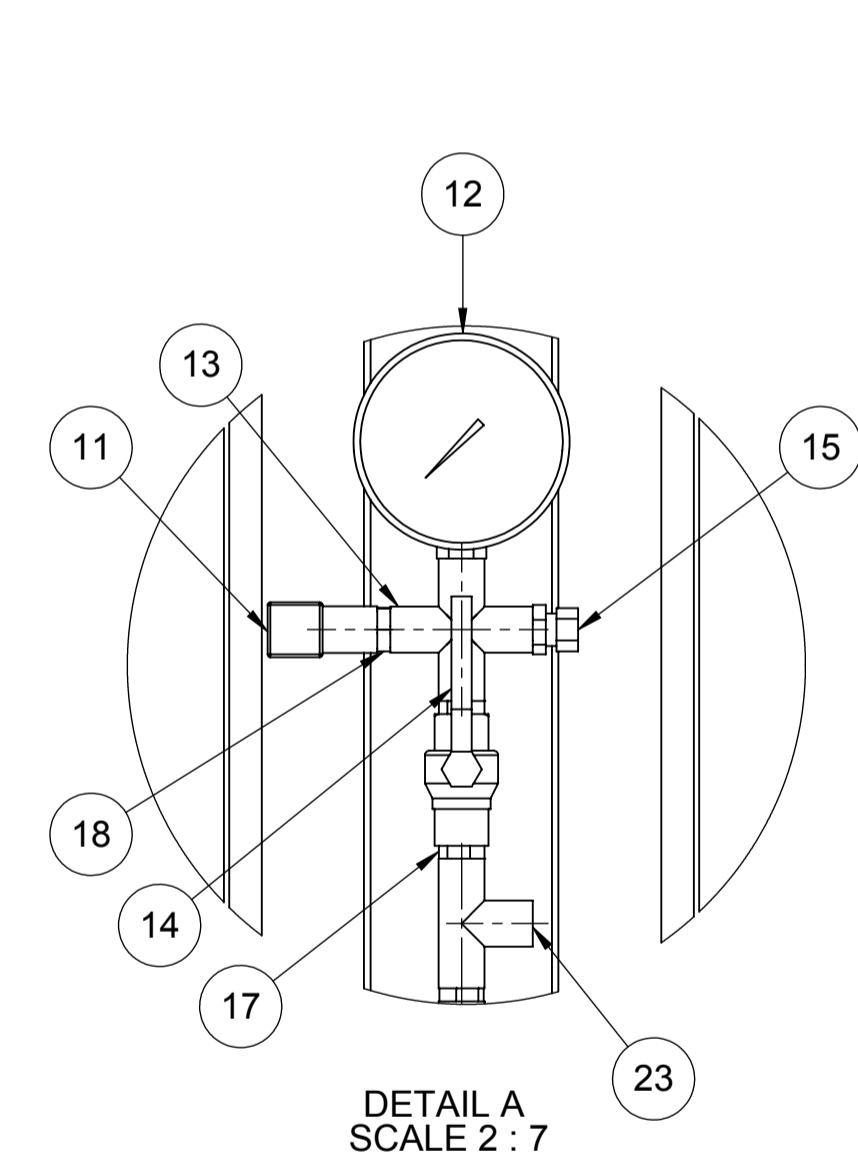

ANTI-VIBRATION MOUNTINGS OPTIONAL ONLY SUPPLIED WHEN ORDERED (4-PER SET K2092/10)

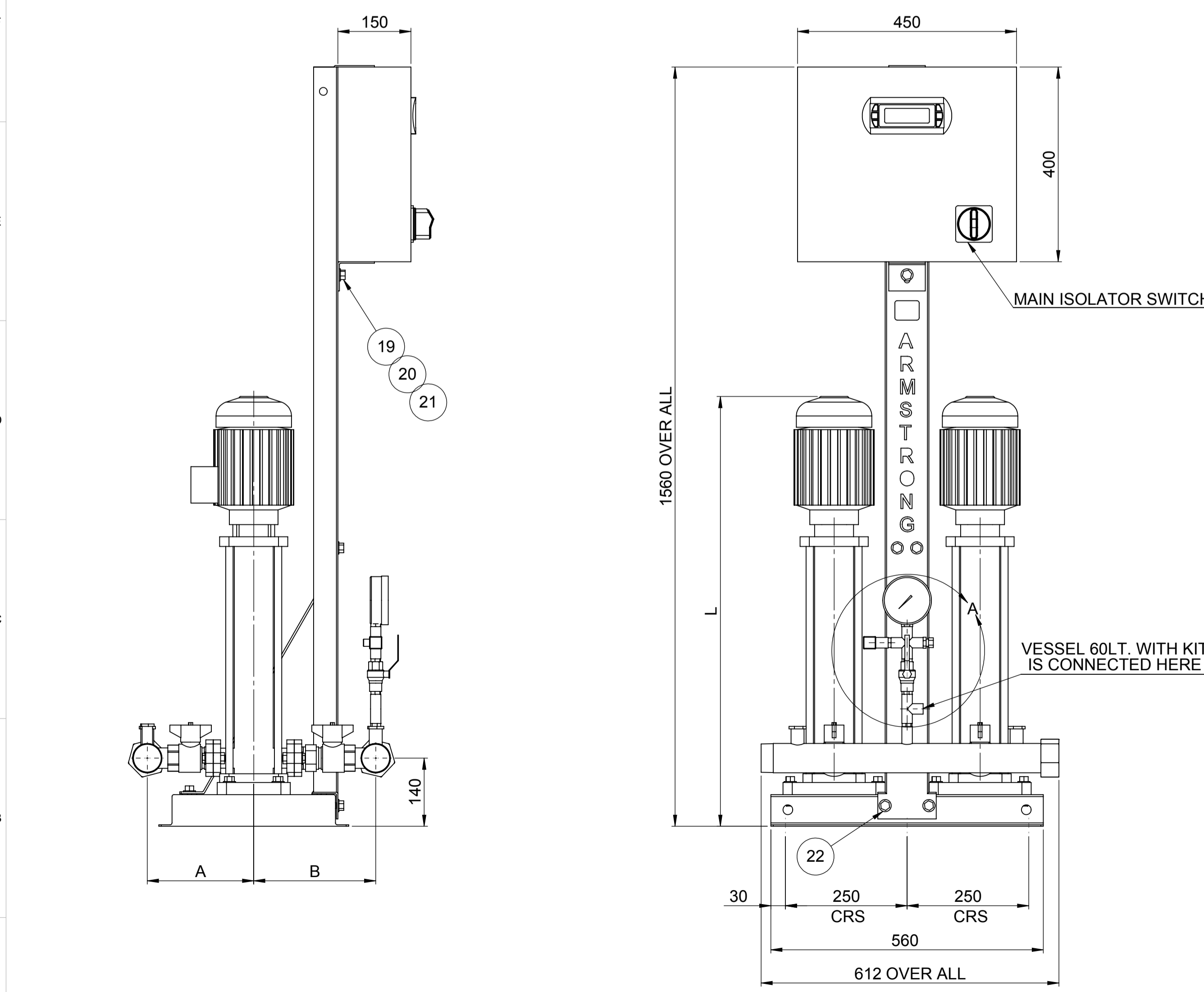
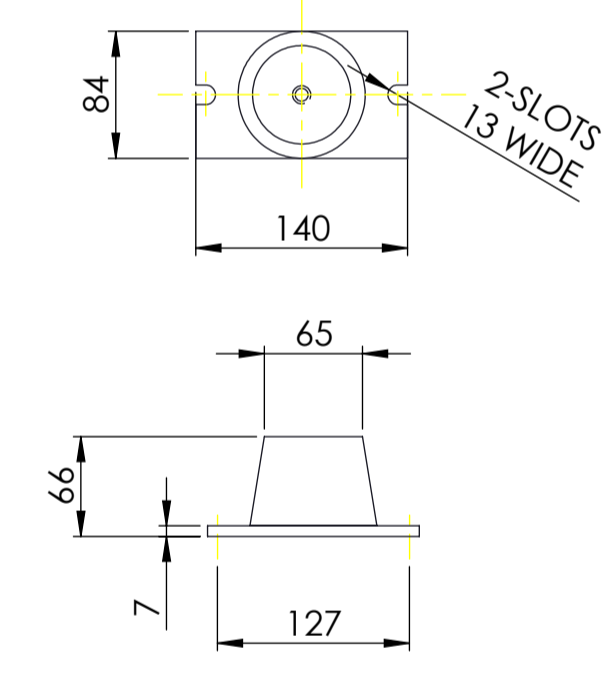

FLEXIBLE CONNECTORS OPTIONAL ONLY SUPPLIED WHEN ORDERED (2-PER SHEET)

- NOTE:-
- 1) MAIN POWER SUPPLY TO PANEL MUST BE SIZED TO COVER ALL PUMPS RUNNING AT THE SAME TIME
 - 2) LARGE STORAGE VESSELS, IF ORDERED, WILL BE SUPPLIED LOOSE FOR POSITIONING FOR CLIENT TO SUIT THE AVAILABLE FLOOR SPACE. CLIENT IS TO PROVIDE A CONNECTION FROM THE VESSEL TO THE DELIVERY PIPEWORK ADJACENT TO THE SET ISOLATING AND DRAIN VALVES SHOULD BE FITTED IN THIS CONNECTION
 - 3) 60 Lt TANK WILL BE SUPPLIED LOOSE AND SHOULD BE ASSEMBLED ON SITE
 - 4) FLANGES ARE AVAILABLE BOTH IN 16 & 25 BAR VERSION
 - 5) FOR STANCHION SELECTION USE DRAWING NO. PK14967

ITEM NO	DESCRIPTION	NO. OFF
1	BASE PLATE	1
2	BOLT - M12	8
3	WASHER - M12	8
4	CAGE NUT - M12	8
5	VMS PUMP	2
6	SUCTION/DISCHARGE MANIFOLD ASSY	2
7	ISOLATING VALVE 1 1/4"	4
8	NRV 1 1/4"	2
9	SUPPORT RIB	1
10	STANCHION	1
11	PRESSURE TRANSDUCER	1
12	PRESSURE GAUGE	1
13	FEMALE CROSS 1/2"	1
14	ISOLATING VALVE 1/2"	1
15	AIR VENT 1/4"	1
16	CONTROL PANEL	1
17	1/2" NIPPLE	3
18	1/2" x 1/4" REDUCING BUSH	3
19	BOLT - M10	9
20	WASHER - M10	9
21	NUT - M10	3
22	CAGE NUT - M10	6
23	1/2" T	1
24	END CAP	2

LAST MODIFICATION DETAILS		PROPRIETARY AND CONFIDENTIAL		UNLESS OTHERWISE SPECIFIED: DIMENSIONS ARE IN MM		DRAWN: PRAKASH		DATE: 01/03/08			
REV:	DATE:	DRN BY:	CHECKED BY:	APP. BY:	THIS DRAWING IS THE PRIVATE AND CONFIDENTIAL PROPERTY OF ARMSTRONG ALL COPYRIGHT, MANUFACTURING AND SALES RIGHTS RESERVED.	WELD SYMBOLS TO BS 499 SURFACE FINISH SHOWN IN UNITS	CHECKED:	Q.A.	MFG APPR.	ENG APPR.	TITLE: 6800 HMP SERIES 2PUMP SV04
					MACHINE WHERE SHOWN TO TOLERANCE ± 0.3		MATERIAL SPEC: BS 308		DO NOT SCALE		SIZE: A1
					THIRD ANGLE PROJECTION		DRAWING RELEASE LEVEL:		SCALE: 1:7		DRG. NO: PX10736
									WEIGHT: KG		REV: B
											SHEET 1 OF 1