

MODEL 5320-33 SEWAGE PUMP EXPLODED VIEW

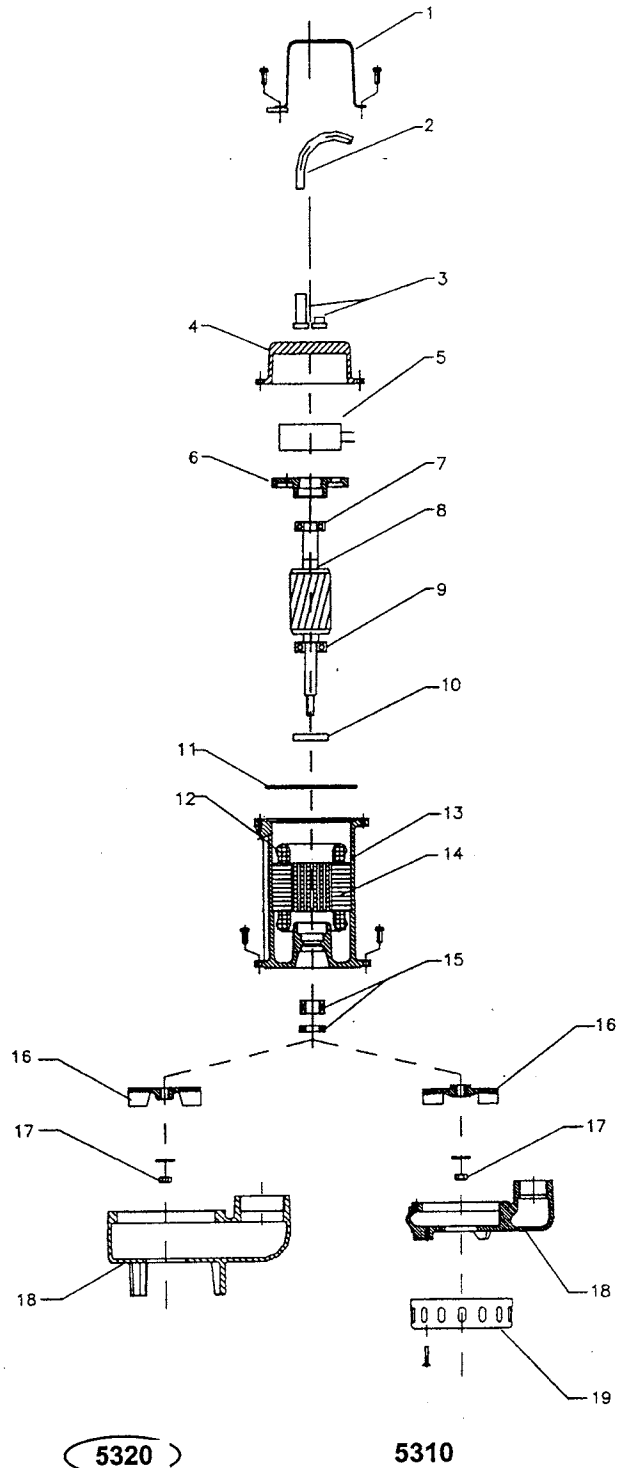

DESCRIPTION	PART NO.
1. HANDLE	
2. CABLE	
3. RUBBER GASKET	
4. MOTOR COVER	
5. CAPACITOR	
6. UPPER BEARING HOLDER	
7. UPPER BALL BEARING	
8. SHAFT WITH ROTOR	442003-025
9. LOWER BALL BEARING	
10. LIP SEAL	442003-010
11. O-RING	
12. WINDING	
13. MOTOR CASE	
14. STATOR	442003-016
15. MECHANICAL SEAL	442003-013
16. IMPELLER	442003-002
17. NUT	
18. PUMP BODY	
19. STRAINER	

Armstrong Pumps Inc.
93 East Avenue
Buffalo, New York
U.S.A. 14120-6594
Tel: (716) 693-8813
Fax: (716) 693-8970
Visit us at www.armstrongpumps.com

S.A. Armstrong Limited
23 Bertrand Avenue
Toronto, Ontario
Canada, M1L 2P3
Tel: (416) 755-2291
Fax: (416) 759-9101



© S. A. Armstrong Limited 2002

Armstrong Pumps Limited
Peartree Road, Stanway
Colchester, Essex
United Kingdom, C03 0LP
Tel: 01206-579491
Fax: 01206-760532

Armstrong Darling
2200 Place Transcanadienne
Montreal, Quebec
Canada, H9P 2X5
Tel: (514) 421-2424
Fax: (514) 421-2436

