

INSTALLATION AND OPERATING INSTRUCTIONS

ARMSTRONG

Soldered Circuit Balancing Valves

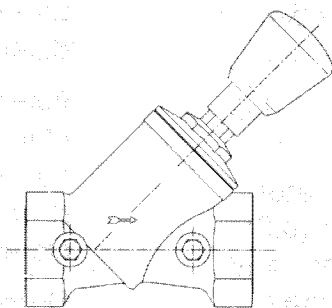

SWEAT STYLE

INSTALLATION

- To ensure accuracy of measurement this CBV should be located at least five pipe diameters downstream from any fitting and at least ten pipe diameters downstream from a pump. Two pipe diameters downstream from the CBV should be free of any fittings (as illustrated).

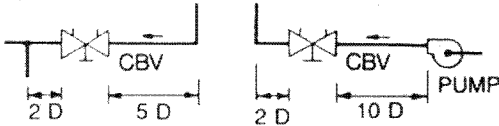

- CBV valves must be installed with flow in the direction of the arrow on the valve body. Easy access to the probe metering ports (P.M.P.'s), drain ports and handwheel must be provided.
- Remove the valve-bonnet assembly and metering ports from valve body.
- Solder the valve body in line using 95/5 solder or equal.
- Install the valve-bonnet assembly into body, making sure non-asbestos gasket is in place.
- Close the valve using the red handwheel, with the black turn indicator removed.
- Remove the handwheel and thread the black turn indicator into it to a 0.0 setting. (Shown in Fig. 1).
- Install the handwheel and turn indicator held together in the closed position (0.0), by pushing them over the valve stem and hex guide post of the bonnet until they snap in place.
- Locate cover on top of handwheel and press until cover snaps into place.
- Using a thread sealant, install the P.M.P.'s into 1/4" N.P.T. holes in the valve body.

NOTE: Valve-bonnet assembly and P.M.P.'s must be installed after soldering to protect the valve seals.

- CBV valves can be installed in horizontal or vertical piping. The metering ports should never be installed below the pipe, (pointing down) as this will allow system sediment to accumulate in the ports. (Illustrated below for horizontal and vertical piping).

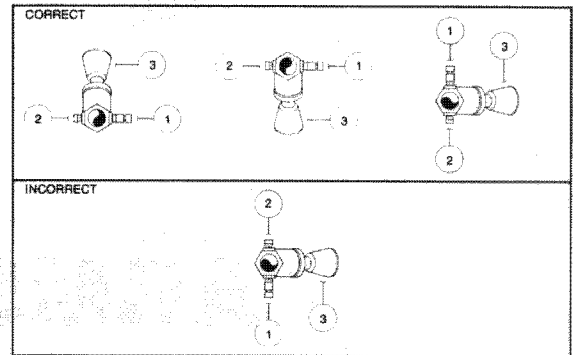

(1) Metering Port

(2) Body Plug & Drain

(3) Handwheel

- Metering ports and body/drain plugs may be interchanged for improved accessibility.
- Drain valves are available as an accessory. When required, the two 1/4" NPT connections with plugs are provided for drain valve installation.
- The valve operates from closed to fully open by a counterclockwise rotation of the red handwheel using four 360-degree turns. The position of the valve is indicated by two scales.

Inner Scale — This scale is printed on a black sleeve which moves linearly within the red handwheel. This sleeve has an arrowed scale marked 0 - 4, (0) denoting closed and (4) being fully opened.

Outer Scale — This scale is a micrometer type scale 0 - 9 marked at the tapered base of the red handwheel. Each gives 1/10th indications for each 360-degree turn of opening against the indicator line of the Inner Scale.

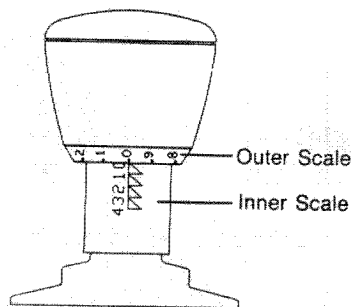

(FIG. 1) With all arrows visible, the Inner Scale set at 0 on the indicator line aligned with the 0 on the Outer scale; the valve is closed.

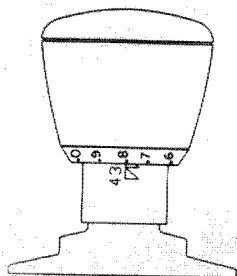

(FIG. 2) Shows a valve setting of 2.8 indicating that the valve is partially open.

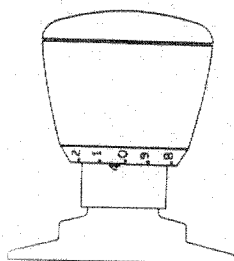

(FIG. 3) With no arrows visible, the Inner Scale set at 4 and the indicator line aligned with Outer Scale 0; the valve setting is 4.0 and the valve is fully open.

15. Connect meter quick-disconnect hoses to metering ports as follows:
 - Remove protective cap from metering ports.
 - Insert and lock the meter probe into the metering ports. The hose with the red fitting, upstream; the hose with the blue fitting, downstream.

CAUTION: The probe should not be left inserted into the fitting for prolonged periods of time, overnight, etc., as leakage of the P.M.P. may occur when the probe is removed.

The locking nut on the probe is designed to hold it in the P.M.P. when taking readings in systems having a high working pressure. As sealing is accomplished internally on the probe stem, it is only necessary to tighten the locking nut finger-tight. Over-tightening may cause damage to the P.M.P. or locking nut threads.

16. Before taking a flow measurement reading, set the valve to its fully open (4.0) or at a pre-set position. Read the pressure drop across the valve with an Armstrong CBDM-135/60 or CBDM-60 meter. Determine GPM flow by use of valve C, curve on Page 4 or the Armstrong Circular Slide Rule.

MEMORY SETTING

17. After valve has been adjusted and without moving the handwheel, insert a standard flat-blade screwdriver into the slot provided in the upper part of the handwheel. (Fig.4) Gently pry the cap off. Insert a $\frac{3}{32}$ " allen wrench into the metal set screw, located approximately $\frac{1}{2}$ " off center, next to the valve stem. Turn the set screw in a clockwise direction until it stops. It is not necessary to tighten. The memory has now been set. Align cap on to the handwheel and snap into position. Valve may now be closed tightly and reopened to the memory set position.

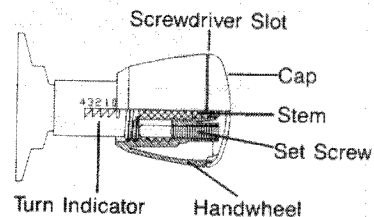

(FIG. 4) Memory Setting

REPOSITIONING HANDWHEEL

18. The handwheel can be removed in any of six positions around the stem.
 - a) Close valve carefully.
 - b) Remove handwheel cap per Item 17.
 - c) Remove handwheel and turn indicator sleeve by grasping the handwheel and pulling away from the valve body along the stem.
 - d) Select a new position for easy reading, and with the sleeve and handwheel held together in the closed position (0.0), push them back over the bonnet hex and valve stem until they snap in place.
 - e) Replace handwheel cap per Item 17.
 - f) Open valve.
19. If handwheel is removed for any reason, it is important to first close the valve and then replace the handwheel per 18 d) and e) above.

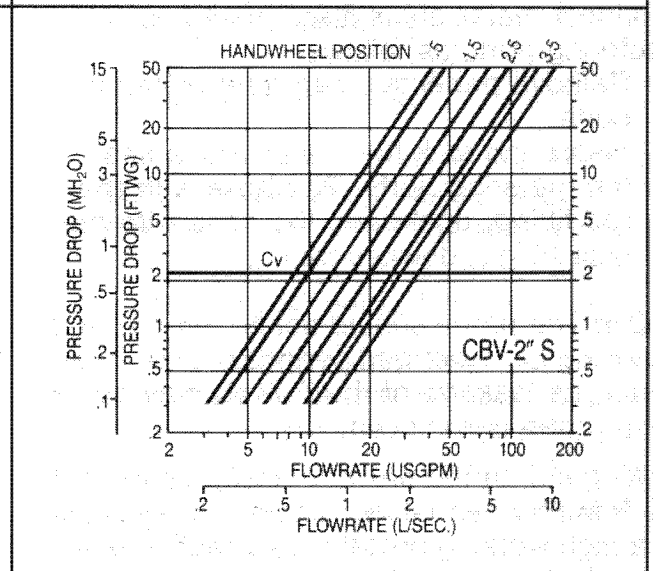
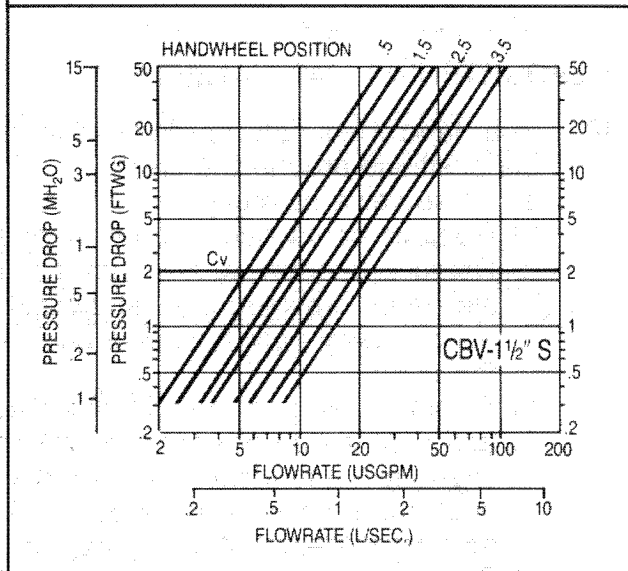
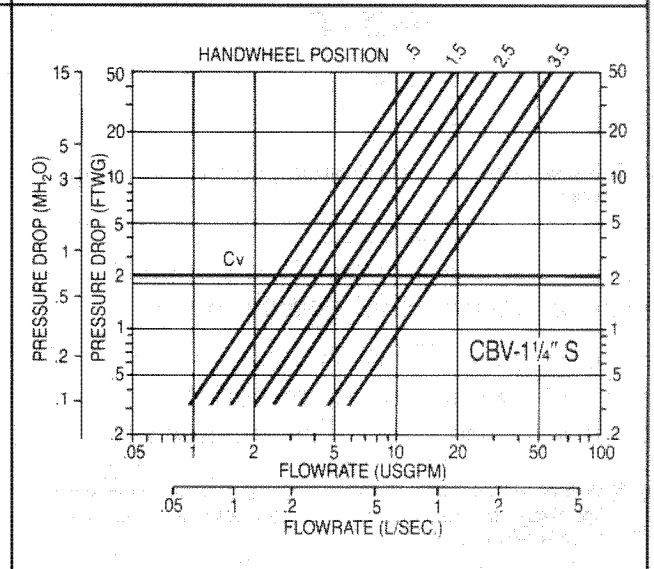
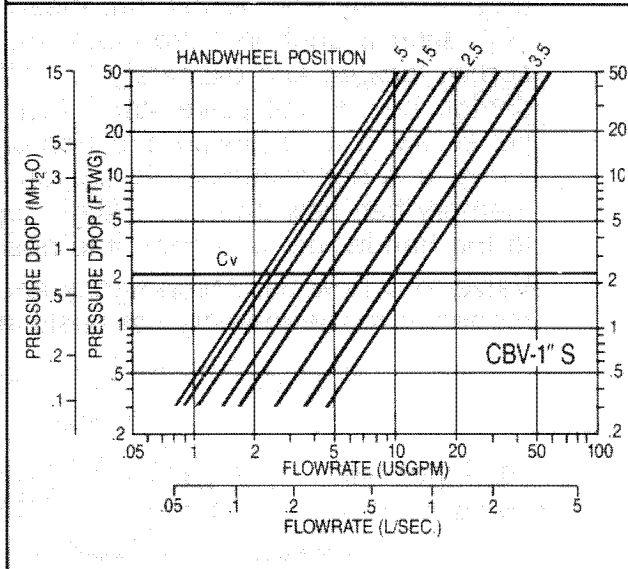
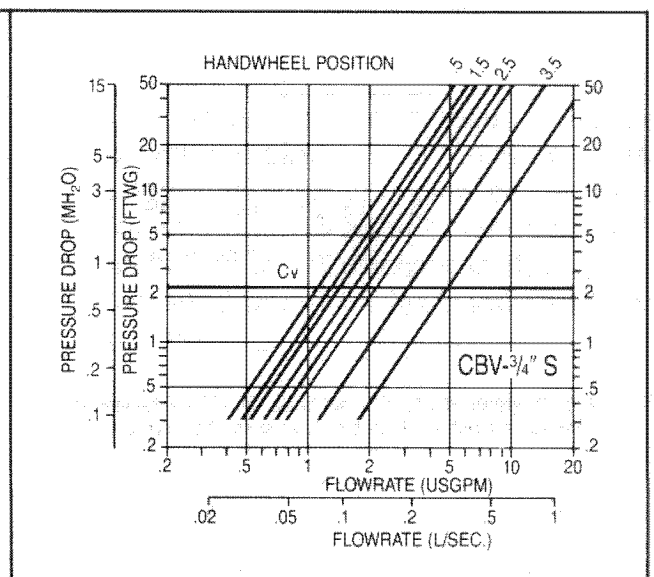
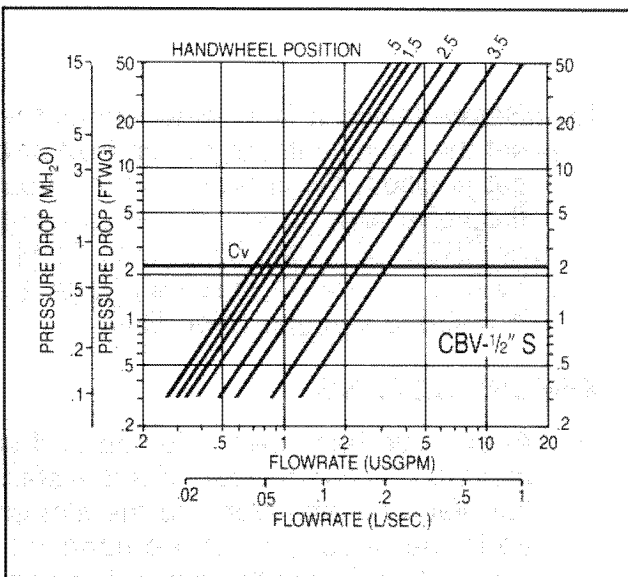

S.A. Armstrong Limited
 23 Bertrand Avenue
 Toronto, Ontario
 Canada, M1L 2P3
 Tel: (416) 755-2291
 Fax: (416) 759-9101

Armstrong Pumps Limited
 Peartree Road, Stanway
 Colchester, Essex
 United Kingdom, C03 5JX
 Tel: 01206-579491
 Fax: 01206-760532



Armstrong Pumps Inc.
 93 East Avenue
 Buffalo, New York
 U.S.A. 14120-6594
 Tel: (716) 693-8813
 Fax: (716) 693-8970
 1-800-FLOW-845

Armstrong Darling Inc.
 2200 Place Transcanadienne
 Montreal, Quebec
 Canada, H9P 2X5
 Tel: (514) 421-2424
 Fax: (514) 421-2436

Printed in Canada