



Installation Instructions Models SPU606 and SPU626



ESSENTIAL SAFETY REQUIREMENTS

- 1) Locate units in a well ventilated environment and ensure that ventilation fans and apertures are not obstructed.
- 2) Check the supply voltage and overload protection is correct.
- 3) Electrical installation should be performed by a competent electrician.
- 4) Guards and covers must not be removed during operation.

Install the unit as indicated in the diagram below.

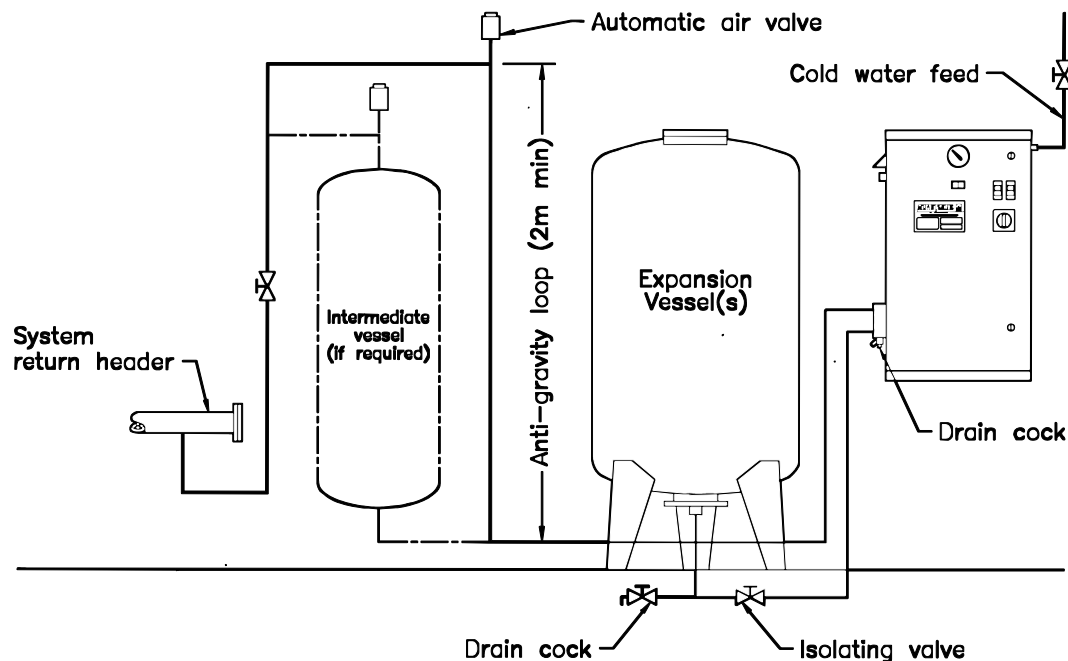

NOTES:

- 1) The pipework from the system to the expansion vessels should not be lagged.
- 2) An anti-gravity loop with a minimum height of 2m (or an intermediate vessel) should be installed to provide thermal protection to the expansion vessels.
- 3) For chilled water systems the connections to the intermediate vessel should be reversed, i.e. bottom to system, and top to expansion vessel
- 4) The SPU unit can be floor or wall mounted. If it is to be wall mounted ensure that sufficient room is left above the unit (500mm minimum) to allow the lid to be removed and the break tank components to be accessed.
- 5) The ball float valve is fitted with a low pressure seat, a high pressure seat is attached to the float valve and should be fitted if required.
- 6) The pipework to the expansion vessels should be sized according to the size and number of vessels and should be at least the same size as the vessel connection.
- 7) Where multiple expansion vessels are required it is recommended that each vessel be installed with its own isolating valve and drain cock.
- 8) If a finished floor screed is to be applied on completion of all mechanical services, then it is advisable that all floor mounted equipment is mounted on a concrete plinth.

Electrical Connections

Wire the incoming supply to the isolator in accordance with the relevant diagram shown below:-

NOTE: The supply to this unit should not be interrupted by a time clock or safety cut-out.

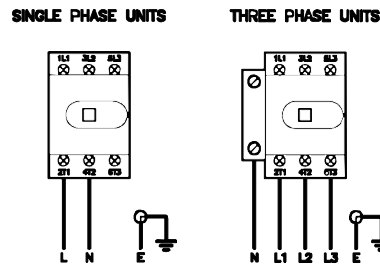

Volt-free connections are shown below:-

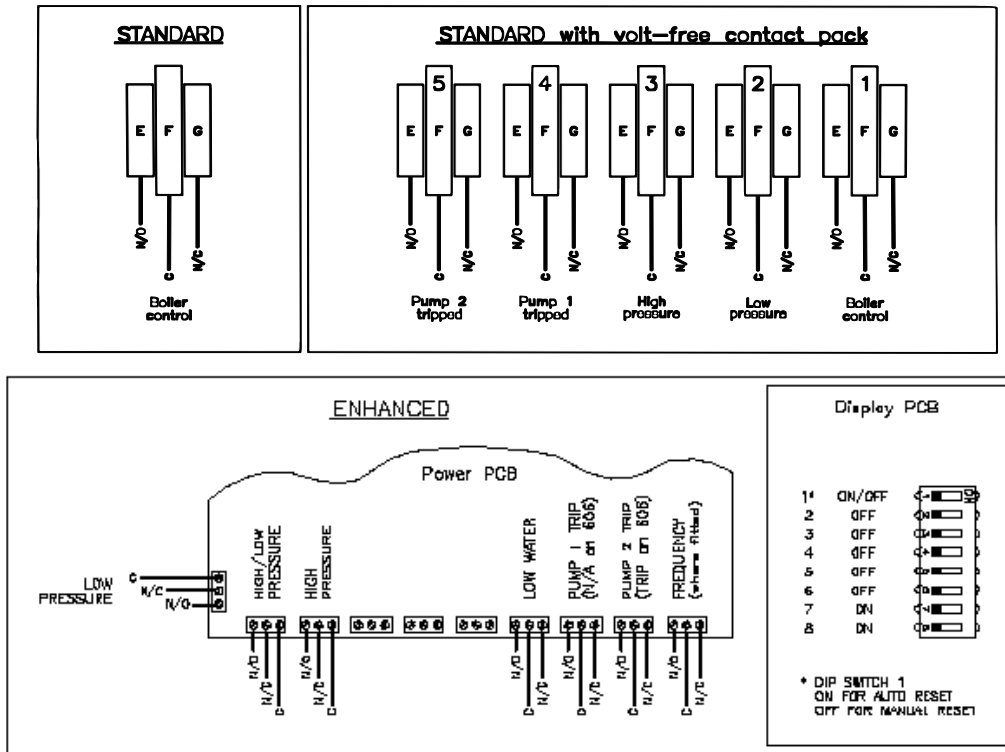

Standard units have a single volt-free contact (boiler control). If the system goes into either low or high pressure the contacts are opened.

Enhanced and frequency units have additional volt-free contacts to indicate low water in the break tank and pump tripped. The boiler control relay is duplicated to allow high or low pressure to be indicated to a BMS.

Each volt free contact consists of a common connection and a normally open and normally closed connection. N.B. The maximum current through any of the volt-free contacts should be limited to 1amp.

S. A. Armstrong Limited
23 Bertrand Avenue
Toronto, Ontario
Canada, M1L 2P3
T: (416) 755-2291
F (Main): (416) 759-9101

Armstrong Pumps Inc.
93 East Avenue
North Tonawanda, New York
U.S.A. 14120-6594
T: (716) 693-8813
F: (716) 693-8970

Armstrong Holden Brooke Pullen
Wenlock Way
Manchester
United Kingdom, M12 5JL
T: +44 (0) 161 223 2223
F: +44 (0) 161 220 9660



© S.A. Armstrong Limited 2006