

Design Envelope 4200H & 4280

End suction horizontal
pumping units with
permanent magnet
motors up to 10 hp

Installation and
operating instructions

File No: 103.82
Date: NOVEMBER 20, 2023
Supersedes: 103.82
Date: SEPTEMBER 14, 2023

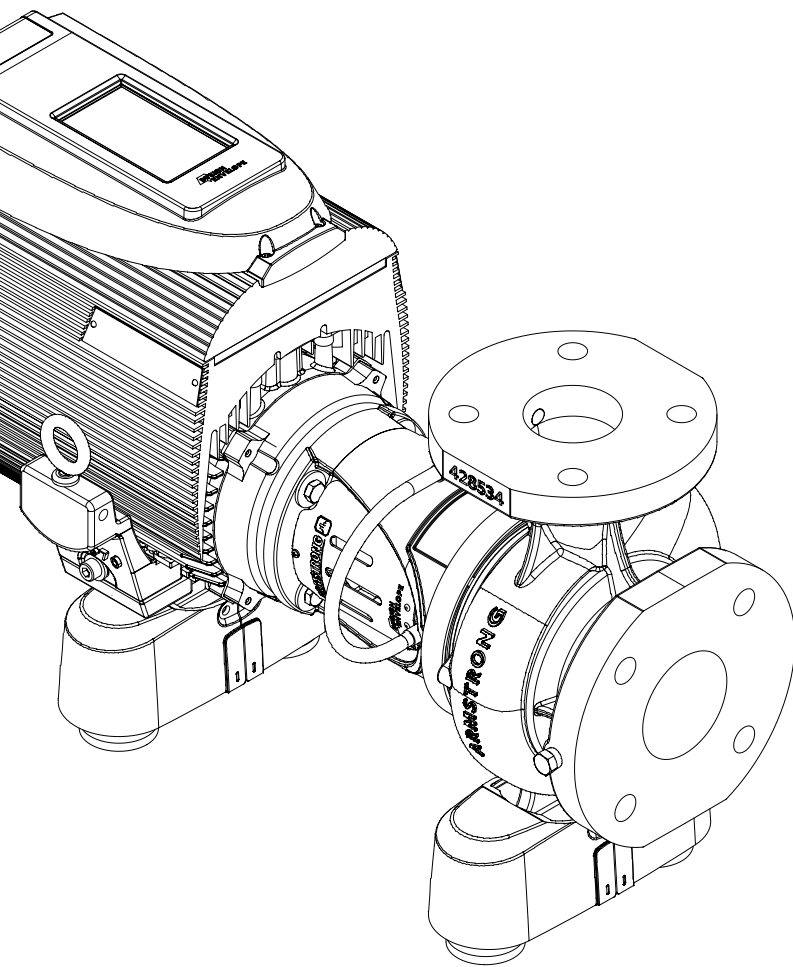

CONTENTS

| | | | |
|--|----|--|--|
| 1.0 INTRODUCTION | 4 | | |
| 1.1 PRECAUTIONS | 4 | | |
| 1.1.1 INSTRUCTIONS FOR SAFE USE | 4 | | |
| 1.1.2 AMBIENT TEMPERATURE | 4 | | |
| 1.1.3 ENCLOSURE RATING | 4 | | |
| 1.1.4 VIBRATION LEVELS | 4 | | |
| 1.1.5 STORAGE | 5 | | |
| 1.1.6 WARRANTY | 5 | | |
| 1.1.7 UNCRATING | 5 | | |
| 1.1.8 HANDLING DESIGN ENVELOPE 4200H & 4280 PUMPING UNITS | 5 | | |
| 1.2 MECHANICAL INSTALLATION | 6 | | |
| 1.2.1 LOCATION | 6 | | |
| 1.2.2 INSTALLATION | 6 | | |
| 1.2.3 SYSTEM INSTALLATION | 6 | | |
| 1.2.4 SUCTION GUIDE | 7 | | |
| 1.2.5 LEVELING | 7 | | |
| 1.2.6 INSTALLATION FOR SEISMIC MOUNTS | 8 | | |
| 1.2.7 VERTICAL SHAFT INSTALLATION | 8 | | |
| 1.2.8 PUMP PIPING – GENERAL | 8 | | |
| 2.0 ELECTRICAL SETUP | 9 | | |
| 2.1 PRECAUTIONS | 9 | | |
| 2.1.1 GROUND LEAKAGE CURRENT | 9 | | |
| 2.1.2 START / STOP OF PUMP | 10 | | |
| 2.1.3 ADDITIONAL MOTOR PROTECTION | 10 | | |
| 2.1.4 MOTOR THERMAL PROTECTION AND DERATING | 10 | | |
| 2.2 ELECTRICAL SPECIFICATION | 11 | | |
| 2.3 ELECTRICAL INSTALLATION | 14 | | |
| 2.3.1 POWER WIRING | 14 | | |
| 2.3.1.1 POWER WIRING FOR FRAME 71 MOTORS – 1 PHASE | 14 | | |
| 2.3.1.2 POWER WIRING FOR FRAME 71 MOTORS – 3 PHASE | 14 | | |
| 2.3.1.3 POWER WIRING FOR DEPM MOTORS | 14 | | |
| 2.3.1.4 POWER WIRING FOR DEPM 2 MOTORS | 14 | | |
| 2.3.2 TOOLS YOU WILL NEED | 15 | | |
| 2.3.3 THE MAIN COVER DISASSEMBLY | 15 | | |
| 2.3.3.1 MAIN COVER DISASSEMBLY – FRAME 71 MOTORS | 15 | | |
| 2.3.3.2 THE MAIN COVER DISASSEMBLY- DEPM | 17 | | |
| 2.3.3.3 THE MAIN COVER DISASSEMBLY- DEPM2 | 18 | | |
| 2.3.4 CONTROL TERMINAL WIRING | 19 | | |
| 2.3.4.1 CONTROL TERMINAL WIRING FOR FRAME 71 MOTORS | 19 | | |
| 2.3.4.2 CONTROL TERMINAL WIRING FOR DEPM MOTORS | 19 | | |
| 2.3.4.3 CONTROL TERMINAL WIRING FOR DEPM2 MOTORS | 20 | | |
| 2.3.5 ANALOG / DIGITAL INPUTS | 20 | | |
| 2.3.5.1 ANALOG / DIGITAL INPUTS FOR FRAME 71 MOTORS | 20 | | |
| 2.3.5.2 ANALOG / DIGITAL INPUTS FOR DEPM MOTORS | 21 | | |
| 2.3.5.3 ANALOG / DIGITAL INPUTS FOR DEPM2 MOTORS | 22 | | |
| 2.3.6 ANALOG / DIGITAL OUTPUT | 22 | | |
| 2.3.6.1 ANALOG OUTPUT FOR FRAME 71 MOTORS | 22 | | |
| 2.3.6.2 DIGITAL OUTPUT FOR FRAME 71 MOTORS | 22 | | |
| 2.3.6.3 ANALOG OUTPUT FOR DEPM MOTORS | 22 | | |
| 2.3.6.4 DIGITAL OUTPUT FOR DEPM MOTORS | 22 | | |
| 2.3.6.5 ANALOG OUTPUT FOR DEPM2 MOTORS | 22 | | |
| 2.3.6.6 DIGITAL OUTPUT FOR DEPM2 MOTORS | 22 | | |
| 2.3.7 RELAY OUTPUT | 23 | | |
| 2.3.7.1 RELAY OUTPUT FOR FRAME 71 MOTORS | 23 | | |
| 2.3.7.2 RELAY OUTPUT FOR DEPM MOTORS | 23 | | |
| 2.3.7.3 RELAY OUTPUT FOR DEPM2 MOTORS | 23 | | |
| 2.3.8 SUPPLY VOLTAGE | 23 | | |
| 2.3.9 SUPPLY FUSING | 23 | | |
| 2.4 DESIGN ENVELOPE PUMP CONTROLLER WIRING | 24 | | |
| 2.4.1 BATTERY | 24 | | |
| 2.4.2 ETHERNET CONNECTIVITY | 24 | | |
| 2.4.3 CAN BUS WIRING | 24 | | |
| 2.4.4 RS 485 WIRING | 24 | | |
| 2.4.5 NETWORKING OPTIONS | 24 | | |
| 3.0 NETWORKING CONTROLS | 25 | | |
| 3.1 MODBUS REGISTER MAP – VERSION 1 - FOR FIRMWARE V1.16 AND OLDER | 26 | | |
| 3.2 BACNET OBJECTS – VERSION 1 - FOR FIRMWARE V1.16 AND OLDER | 28 | | |
| 3.3 MODBUS REGISTER MAP – VERSION 2 - FOR FIRMWARE V1.17 AND NEWER | 30 | | |
| 3.4 BACNET OBJECTS – VERSION 2 - FOR FIRMWARE V1.17 AND NEWER | 32 | | |
| 4.0 OPERATION | 34 | | |
| 4.1 START-UP CHECKLIST | 34 | | |
| 4.2 STARTING PUMP | 34 | | |
| 4.2.1 AUTO FLOW BALANCING | 34 | | |
| 4.3 TOUCH SCREEN | 35 | | |
| 4.3.1 LOGIN | 35 | | |
| 4.3.2 LOGOUT | 35 | | |
| 4.3.3 ABOUT | 36 | | |
| 4.3.4 GENERAL SETTINGS | 37 | | |

| | | | | | |
|------------|--|----|-------------|---|----|
| 4.3.5 | MANUAL/AUTO MODE | 38 | 6.3.1 | MECHANICAL SEAL REPLACEMENT INSTRUCTIONS FOR RIGID SPLIT- COUPLED PUMPING UNITS (SERIES 4300, 4200H & 4322) | 56 |
| 4.3.6 | PUMP CONTROL | 39 | 6.3.2 | MECHANICAL SEAL REPLACEMENT INSTRUCTIONS FOR CLOSE-COUPLED PUMPING UNITS (SERIES 4380, 4280 & 4372) | 57 |
| 4.3.7 | ALARMS & WARNINGS | 41 | 6.4 | SYSTEM CLEANLINESS | 59 |
| 4.3.8 | TREND-GRAPH | 42 | 7.0 | WARNINGS AND ALARMS | 59 |
| 4.3.9 | BRIGHTNESS ADJUSTMENT | 42 | 7.1 | ALARM SUMMARY FOR INTERFACES | 59 |
| 4.3.10 | TOUCH SCREEN CALIBRATION | 43 | 7.2 | WARNING SUMMARY FOR INTERFACES | 60 |
| 4.3.11 | DATA LOGGING | 44 | 8.0 | FUSE AND WIRE RECOMMENDATION | 61 |
| 4.4 | WEB INTERFACE | 45 | 9.0 | PUMP MANAGER | 62 |
| 4.4.1 | CONNECTING VIA ETHERNET | 45 | 10.0 | CONNECTIVITY KIT | 63 |
| 4.4.2 | CONNECTING VIA WIFI | 45 | | | |
| 4.5 | DESIGN ENVELOPE FLOW READOUT TOLERANCE | 47 | | | |
| 4.6 | NOISE LEVELS | 47 | | | |
| 5.0 | CONTROL MODES | 48 | | | |
| 5.1 | CONSTANT FLOW | 48 | | | |
| 5.2 | CONSTANT PRESSURE | 48 | | | |
| 5.3 | LINEAR PRESSURE | 48 | | | |
| 5.4 | QUADRATIC CURVE CONTROL | 48 | | | |
| 5.5 | QUADRATIC CURVE CONTROL WITH MINIMUM FLOW PROTECTION | 48 | | | |
| 5.6 | QUADRATIC CURVE CONTROL WITH MAXIMUM FLOW PROTECTION | 48 | | | |
| 5.7 | QUADRATIC CURVE CONTROL WITH MINIMUM & MAXIMUM FLOW PROTECTION | 49 | | | |
| 5.8 | PARALLEL SENSORLESS PUMP CONTROL (PSPC) | 49 | | | |
| 5.8.1 | EMBEDDED PARALLEL SENSORLESS PUMP CONTROL FOR MULTIPLE PUMPS | 49 | | | |
| 5.8.2 | MODIFYING MOTOR RAMP UP AND DOWN TIME | 50 | | | |
| 5.8.3 | THREE DIFFERENT CONTROL MODES CAN BE ACCESSED | 51 | | | |
| 5.8.4 | FALLBACK PERCENTAGE OF MAXIMUM SPEED | 51 | | | |
| 5.8.5 | STANDBY PUMPS | 51 | | | |
| 5.9 | 2*100% CAPACITY SPLIT UNITS | 51 | | | |
| 5.10 | ALTERNATION | 51 | | | |
| 5.11 | CONSTANT PRESSURE CONTROL | 52 | | | |
| 5.12 | DUAL SEASON SETUP | 52 | | | |
| 5.13 | SENSORED CONTROL | 52 | | | |
| 5.13.1 | ADDING DP SENSORS THROUGH LCD SCREEN | 52 | | | |
| 5.13.2 | ADDING DP SENSORS FROM WEBSERVER | 52 | | | |
| 5.14 | BYPASS VALVE CONTROL | 53 | | | |
| 6.0 | MAINTENANCE | 55 | | | |
| 6.1 | GENERAL CARE | 55 | | | |
| 6.2 | LUBRICATION | 55 | | | |
| 6.3 | MECHANICAL SEAL | 55 | | | |

Note: Document subject to change.

1.0 INTRODUCTION

This manual contains specific information regarding the safe installation, operation and maintenance of Armstrong Design Envelope pumps. Read this manual carefully before installing or using the product. If clarification is needed on any point please contact Armstrong quoting the equipment serial number.

1.1 PRECAUTIONS

1.1.1 INSTRUCTIONS FOR SAFE USE

 No installation of this equipment should take place unless this document has been studied and understood. Handling, transportation and installation of this equipment should only undertaken by trained personnel with proper use of lifting equipment. See later diagrams for lifting advice. Refer to the pump nameplate for pump speed, pressure and temperature limitations. The limits stated must not be exceeded without written permission from Armstrong.

1.1.2 AMBIENT TEMPERATURE

 Install the Design Envelope unit with adequate access for routine maintenance. A minimum of 2" (50 mm) clearance is required at the fan inlet to facilitate airflow. Where several Design Envelope units are installed in close proximity, care must be taken to ensure that there is no re-circulation of exhausted warm air.

 To avoid the DEPM unit getting overheated, the ambient temperature is not to exceed the average daily temperature. Operating in higher ambient temperatures will require derating of the DEPM unit (See section 2.1.4 for details).

Under normal operating conditions the pump surface temperature may reach 155°F/68°C (Restricted Zone) to 176°F/80°C (Unrestricted Zone). Steps should be taken to minimize contact or warn operators/users that normal operating conditions will be exceeded. In certain cases, where the temperature of the pumped liquid exceeds the above stated temperature levels, pump casing temperatures may exceed 212°F/100°C and not withstanding pump insulation techniques appropriate measures must be taken to minimize risk for operating personnel.

1.1.3 ENCLOSURE RATING

 The standard enclosure rating for Design Envelope 4200H and Design Envelope 4280 integrated controls is UL Type 12 / IP55. If the pump is to be installed in a wet or dusty environment, then a higher enclosure rating may be required (contact Armstrong).

1.1.4 VIBRATION LEVELS

Armstrong end-suction horizontal pumps are designed to meet vibration levels set by Hydraulic Institute Standard HI Pump Vibration 9.6.4. Standard levels are as detailed below

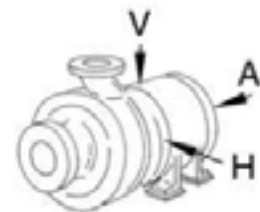
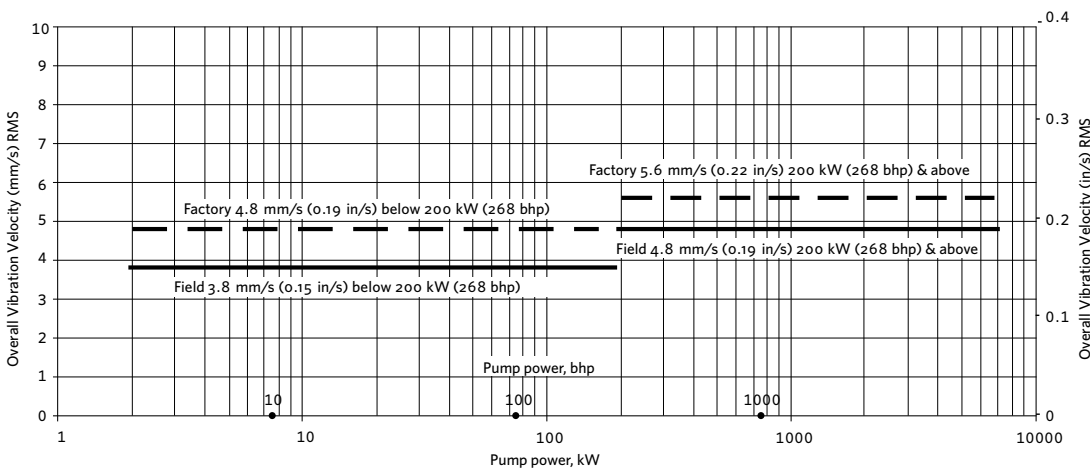

1.1.5 STORAGE

Pumps not immediately placed into service, or removed from service and stored, must be properly prepared to prevent excessive rusting. Pump port protection plates must not be removed until the pump is ready to connect to the piping.

Rotate the shaft periodically (at least monthly) to keep rotating element free and bearings fully functional.

For long term storage (longer than three months), the pump must be placed in a vertical position in a dry environment.

Internal rusting can be prevented by removing the plugs at the top and bottom of the casing and drain or air blow out all water to prevent rust buildup or the possibility of freezing. Be sure to reinstall the plugs when the unit is made operational. Rust proofing or packing the casing with moisture absorbing material and covering the flanges is acceptable. When returning to service be sure to remove the drying agent from the pump.

1.1.6 WARRANTY

Armstrong's warranty period for Design Envelope pumps is [18] months from date of shipment, or [12] months from date of installation, whichever comes first. Please refer to File 9.10US / 9.10C for full terms and conditions. To receive an additional six [6] months of standard coverage, the owner may register the pump unit at:

www.armstrongfluidtechnology.com/warrantyregistration

1.1.7 UNCRATING

Armstrong pumping units are thoroughly inspected before shipment to assure they meet with your order requirements. After removing the pump from the packaging, make sure the equipment is in good order and that all components are received as called for on the packing list. Any shortages or damage should be reported immediately. Use extreme care in handling the unit, placing slings and hooks carefully so that stress will not be imposed on the integrated controller, pump or motor. **Never place cable slings around the pump shaft or integrated controls.**

1.1.8 HANDLING DESIGN ENVELOPE 4200H & 4280 PUMPING UNITS

To handle Design Envelope 4200H & 4280 units when received on site, secure the pallet after uncovering the unit, then hook straps as detailed below and in FIG 1.1.1 to lift the pumping unit. Connect one set of lifting straps to the lifting rings on each side of the integrated motor. A second lifting strap should be secured around the suction nozzle.

FIG 1.1.1

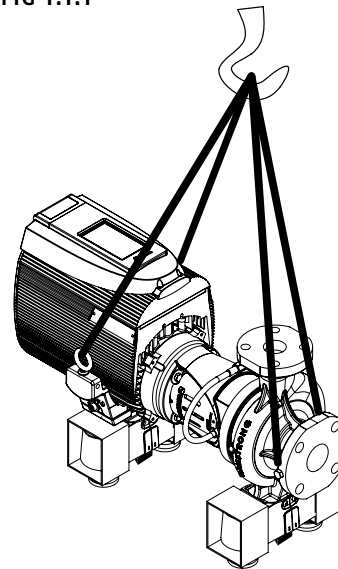

Extra care is required to ensure the integrated controls do not get damaged during lifting and installation. As the lifting device is engaged (using a spacer bar if necessary) and the straps tighten, ensure no part of the strapping is touching any part of the control or motor fan cover.

The Design Envelope 4200H and 4280 pumping units 1-10hp are equipped with integral vibration isolators. Note that the springs are temporarily secured to the pumping unit by 4 sets of packaging sleeves. These must be removed once the pumps are positioned in place.

FIG 1.1.2

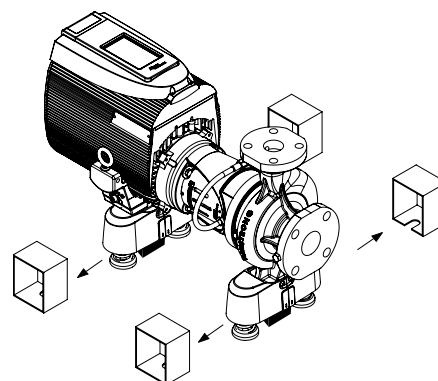

IMPORTANT:



Do not run the pump for any length of time under very low flow conditions or with the discharge valve closed. To do so could cause the water in the casing to reach super heated steam conditions and will cause premature failure and could cause serious and dramatic damage to the pump and surrounding area.

1.2 MECHANICAL INSTALLATION

1.2.1 LOCATION

In open systems, locate the unit as close as practical to the liquid being pumped, with a short, direct suction pipe. Ensure adequate space is left above and around the unit for operation, maintenance, service and inspection of parts.

In closed systems, where possible, the pumps should be installed immediately downstream of the expansion tank / make-up connection. This is the point of zero pressure change and is necessary for effective pump operation. Do not install more than one expansion tank connection into any closed hydronic system. Electric motor driven pumps should not be located in damp or dusty location without special protection.

Airflow into the motor and/or motor fan should not be obstructed.

It is good practice to leave sufficient space around equipment for maintenance and service needs. If the Design Envelope controls are supplied with integral disconnect switches, 36"/1 meter clearance may be required in front of the controls to meet local electrical codes.

1.2.2 INSTALLATION

The Design Envelope 4200H and 4280 pumping units 1-10hp are equipped with integral vibration isolators and **do not require inertia bases or baseplates** for horizontal (shaft orientation), base-mounted installations. The vibration isolators are pre-sized for the pumping unit and will reduce the transmission of noise and vibration from the pump and piping system to the building structure.

FIG 1.2.1

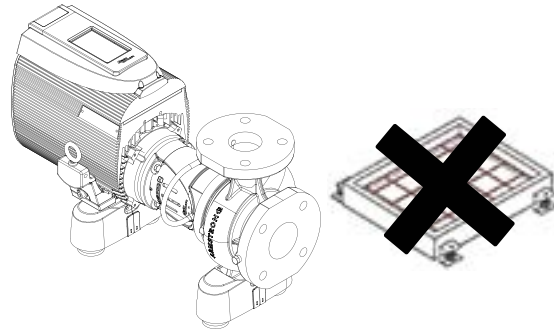

The springs use anti-friction neoprene cup mounts and prevent lateral movement of the pump. If accurate positioning of the spring cups is required, gently use a tool, such as the end of a flat-head screwdriver (or crowbar) to tap the cups into place.

FIG 1.2.2

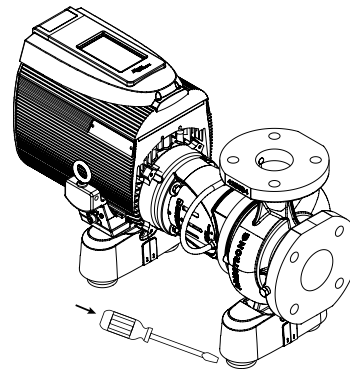

1.2.3 SYSTEM INSTALLATION

Refer to **FIG 1.2.3** for the recommended installation of Design Envelope 4200H and 4280 pumping units 1-10hp pumps.

FIG 1.2.3 A

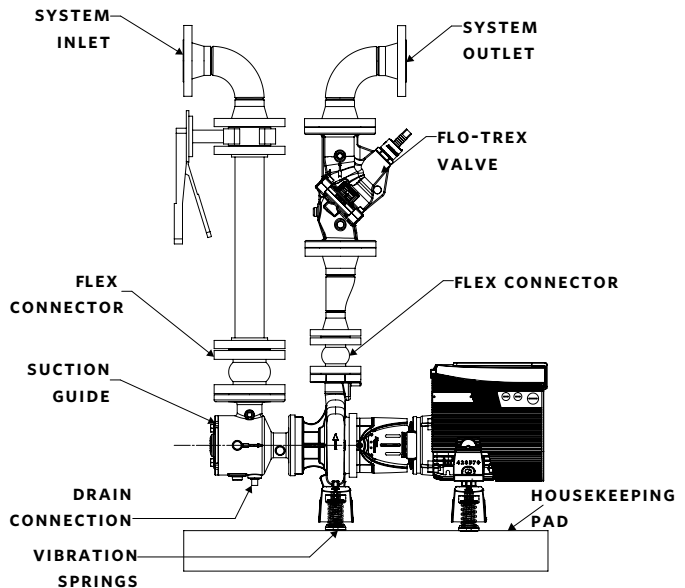

For retrofit installations where it is not practical to remove the previously installed inertia base, refer to **FIG 1.2.3B**

Note the springs on the inertia base must be locked out to allow the pump's integral springs to operate properly.

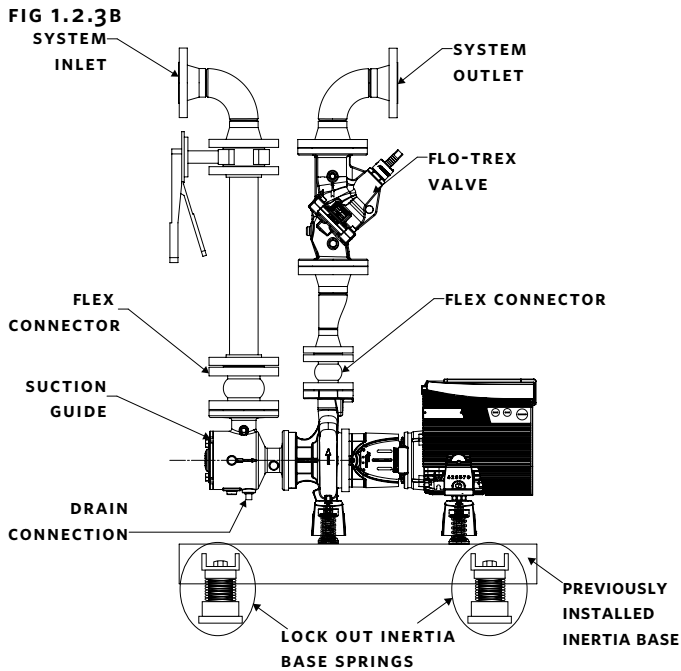

If the installation uses horizontal inlet piping, a flex connector should still be installed before the suction port of the pump.

FIG 1.2.3C

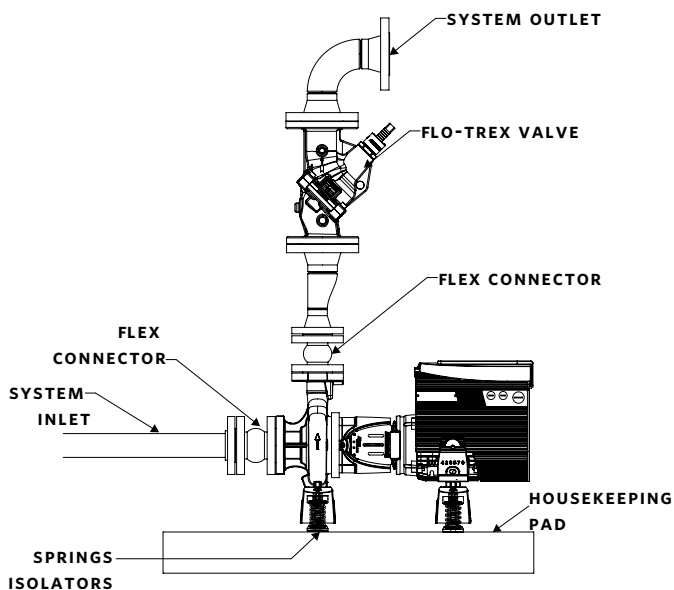

1.2.4 SUCTION GUIDE

It is recommended that suction guides be mounted directly to the pump's suction port. This acts as a counter weight to the weight of the motor to ensure the center of gravity is maintained between the front and back springs isolators. A support pipe under the suction guide should **not** be used - this may transmit forces from the pump or piping system to the ground structure, resulting in unwanted noise or vibration.

FIG 1.2.4

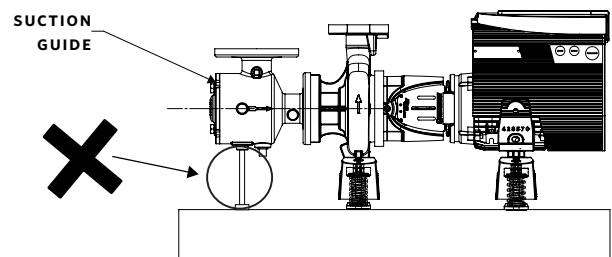

Flex connectors should be installed directly before the suction guide (or suction port), and directly after the pump's discharge port. This will effectively isolate the transmission of noise or vibration between the piping system and the pump.

1.2.5 LEVELING

It is recommended that the Design Envelope 4200H and 4280 pumping units 1-10hp pumps be leveled for general pump operation. Note that these pumps are equipped with support blocks to help pre-level the assembly and provide stability during installation to the piping system.

Once water is added to the piping system, the pumps must be levelled to the final operating weight. Start by removing the shrouds from the front and back of the pump **FIG 1.2.5**. Lift the shrouds up to detach from pump, then remove the two shroud halves apart.

Turn the rubber knobs and continue even adjustment of all mounts until all springs are loaded and mountings are back to Free and Operating Height. It is important that the mounts are all adjusted evenly by working in a clockwise or counter-clockwise pattern as the springs are adjusted. Tighten cap screws to secure equipment.

FIG 1.2.5

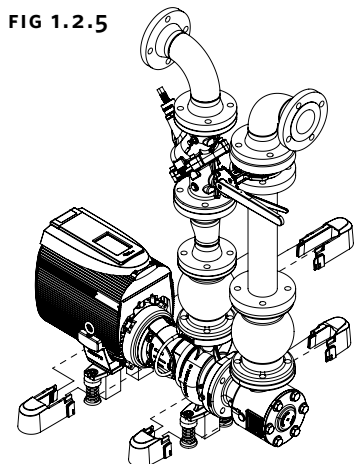

Turn the knob clockwise to increase the free & operating height, or counter-clockwise to decrease the height. The free & operating heights by pump model are listed in the below table

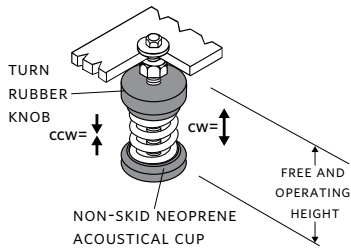

| DE 4200H/4280, SPRING TYPE | FREE & OPERATING HEIGHT |
|-------------------------------|----------------------------|
| Standard Spring Isolators | 3.75" (95 mm) |
| Seismic Mount | 5.00" (127 mm) |

Ensure that the support blocks are removed once the springs are all levelled. The support blocks must be removed for proper vibration isolation (See FIG 1.2.5A).

The shrouds can then be re-assembled to the pump by fastening the 2 halves together around the pump foot and motor foot. Push the shroud assembly down and ensure the shroud pins click into the locator holes in the castings.

FIG 1.2.5A

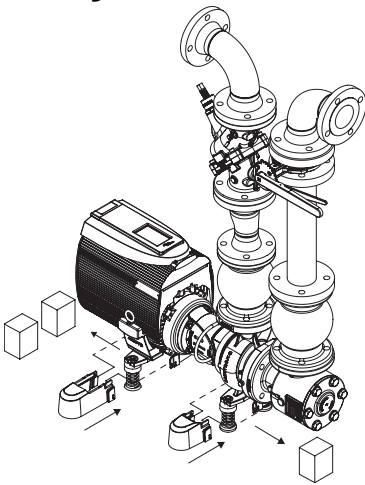

1.2.6 INSTALLATION FOR SEISMIC MOUNTS

Pumps equipped with the Seismic Mount option have seismic mounts factory pre-installed to the feet and must be bolted to the ground structure. Anchor rods may be either cast-in place or post-installed. Ensure the anchoring and mounts are installed along the long side of the pump (as shown in FIG 1.2.6)

FIG 1.2.6

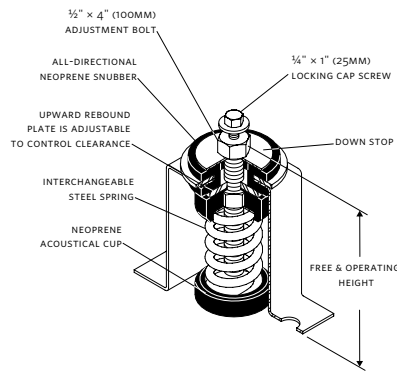
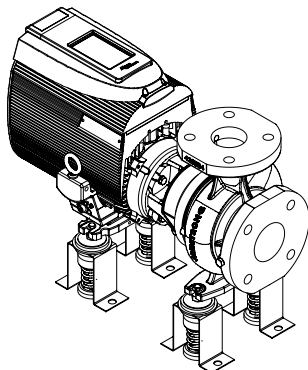

Take 2 full counter-clockwise turns on each leveling bolt and continue even adjustment of all mounts until all springs are loaded and mountings are back to Free and Operating Height. Take no more than two additional counter-clockwise turns on any leveling bolt to level equipment.

Tighten cap screws to secure equipment.

Adjust plates so there is 1/8" (3mm) clearance between top of plate and underside of all-directional neoprene cushion. Turn rebound plates clockwise to lower, or counter-clockwise to raise.

1.2.7 VERTICAL SHAFT INSTALLATION

Design Envelope 4200H and 4280 pumping units 1-10hp may be safely installed in a vertical shaft orientation as shown in FIG 1.2.7. The motor fan must be in an upright position; with the suction port facing down. When installed vertically, the integral springs and shrouds should be removed from the base of pump.

FIG 1.2.7

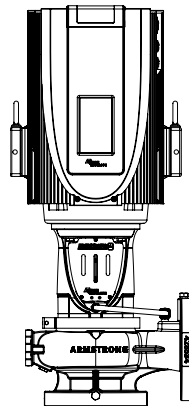

1.2.8 PUMP PIPING - GENERAL

Never connect a pump to piping, unless extra care is taken to measure and align the piping flanges well. Always start piping from pump.

Use as few bends as possible and preferably long radius elbows.

Ensure piping exerts no strain on pump as this could distort the casing causing breakage or early failure due to pump misalignment.

All connecting pipe flanges must be square to the pipework and parallel to the pump flanges.

Suction and discharge pipes may be increased or decreased at pump nozzle to suit pump capacity and particular conditions of installation. Use eccentric reducers on suction connection with flat side uppermost.

Layout the suction line with a continual rise towards the pump without high points, thus eliminating possibility of air pockets that may prevent the pump from operating effectively.

A strainer of three or four times the area of the suction pipe, installed in the suction line, will prevent the entrance of foreign materials into the pump. 1/8" (3 mm) diameter perforations in the strainer is typical.

in open systems, test suction line for air leaks before starting; this becomes essential with long suction line or static lift.

Install, at the pump suction, a straight pipe of a length equivalent to four or six times its diameter; this becomes essential when handling liquids above 120°F (49°C). Armstrong suction guides may be used in place of the straight pipe run and in-line strainer.

Install an isolation valve in both suction and discharge lines on flooded suction application; these valves are used primarily to isolate the pump for inspection or repair.

Install a non-slam non-return check valve in discharge line between pump and isolation valve to protect pump from excessive back pressure and to prevent water running back through the pump in case of driver failure on open systems. Armstrong Flo-Trex valves may be used in place of isolation valves and non-return check valves. Flo-Trex valves use plug & disk design which may also be used for throttling excessive system flow for constant speed pumps and, if necessary, for variable speed pumps. **Do not** throttle variable speed pumps unless absolutely necessary.

NOTE:

Design Envelope 4200H units are accurately aligned at the factory prior to being shipped and do not need re-aligning when installed.

Alignment on a Design Envelope 4200H unit may be verified by assuring an equal and parallel gap between coupling halves on both sides of the coupling.

2.0 ELECTRICAL SETUP

2.1 PRECAUTIONS

Safety, risk of death



All electrical connections should be carried out by a qualified and authorized electrician in accordance with local site regulations and the latest issue of the IEE regulations.



For retrofit applications with multiple pumping units operating in parallel, the ampacity of conductors, ratings of switches, branch-circuit, short circuit and ground-fault protection should be reviewed prior to installation (Reference NEC/NFPA 70 section 430, or OESC section 28).



Before removing the inverter cover, the system must be disconnected from the mains supply. After switching off, wait for at least 15 minutes for the capacitors to discharge before opening the cover.

CAUTION



High voltage testing (Megging) of the motor/inverter may cause damage to the electronic components and therefore should not be carried out.

2.1.1 GROUND LEAKAGE CURRENT



Ground leakage current is primarily caused by the capacitance between motor phases and the motor frame. The RFI filter contributes additional leakage current, as the filter circuit is connected to ground through capacitors.

The size of the leakage current to the ground depends on the following factors, in order of priority:

- 1 Switching frequency
- 2 Motor grounded on site or not

The leakage current is of importance to safety during handling/operation of the pump if (by mistake) the on-board inverter has not been grounded.

Since the leakage current is >3.5mA (approx 4-20mA), reinforced Grounding must be established which is required if EN 50178 is to be complied with. Never use ELCB relays that are not suitable for DC fault currents (type A).

If ELCB relays are used, they must be:

- Suitable for protecting equipment with a direct current content (DC) in the fault current (three-phase bridge rectifier)
- Suitable for power-up with short charging current to Ground
- Suitable for a high leakage current

2.1.2 START / STOP OF PUMP

The number of starts/stops via the mains voltage must not exceed one-time per minute.

If a higher number of starts/stops is required then the start/stop digital input must be used (mains voltage directly connected). This is the preferred method of starting and stopping Pumps.

The three phase mains must be isolated before performing maintenance of the pump.

2.1.3 ADDITIONAL MOTOR PROTECTION



With the exception of supply fuses / MCB's to protect the installation (for over-current and short-circuit protection), no additional overload or over-temperature protection is required (i.e. thermal overloads). Protection features include:

- Mains phase loss
- Over voltage
- Under voltage
- Electronic thermal motor protection
- Short circuit on motor terminals
- Ground fault on motor terminals
- Over temperature

2.1.4 MOTOR THERMAL PROTECTION AND DERATING

The Design Envelope motors are thermally protected in case limits are exceeded (140°C), another protection is provided through the drive.

A DEPM AMBIENT TEMPERATURE DE-RATING

If the motor is operated at temperatures above 104°F (40°C) or 113°F (45°C) (see motor frames below), a derating of the continuous output current (or power) is necessary.

| POWER RANGE | DEPM FRAME SIZE | OUTPUT CURRENT AVAILABLE BY % BASED ON AMBIENT TEMPERATURE | |
|-------------|-----------------|--|--------------|
| | | 113°F (45°C) | 122°F (50°C) |
| 0 - 3HP | DEPM 90 | 100% | 100% |
| 5HP | | 100% | 90% |
| 7.5HP | | 100% | 80% |
| 0 - 7.5HP | DEPM 112 | 100% | 100% |
| 10HP | | 100% | 80% |

| POWER RANGE | DEPM FRAME SIZE | OUTPUT CURRENT AVAILABLE BY % BASED ON AMBIENT TEMPERATURE | |
|-------------|-----------------|--|--------------|
| | | 113°F (45°C) | 122°F (50°C) |
| 0 - 0.75HP | DEPM 71 | 100% | 100% |
| 1 HP | | 100% | 100% |
| 1.5 - 2HP | | 100% | 95% |
| 0 - 2HP | DEPM2 90S* | 100% | 100% |
| 3 - 7.5HP | DEPM2 90 | 100% | 95% |
| 0 - 7.5HP | DEPM2 112 | 100% | 95% |
| 10HP | | 100% | 95% |

*90s for 575V only

B EARTH LEAKAGE CURRENT

Earth leakage current is primarily caused by the capacitance between motor phases and the motor frame. The RFI filter contributes additional leakage current, as the filter circuit is connected to earth through capacitors (Cy).

The size of the leakage current to the ground depends on the following factors, in order of priority:

- 1 Switching PWM frequency
- 2 Motor grounded on site or not

The leakage current is of importance to safety during handling/operation of the drive if (by mistake) the drive has not been earthed.

C OVER VOLTAGE PROTECTION

The voltage in the intermediate circuit is increased when the motor acts as a generator. This occurs in two cases:

- 1 The load generates energy.
- 2 During deceleration (**ramp-down**) if the moment of inertia is high, the load is low and the ramp-down time is too short for the energy to be dissipated as a loss in the motor frequency converter, the motor and the installation.

The drive turns off to protect the IGBT transistors and the intermediate circuit capacitors when a certain voltage level is reached on DCbus.

D MAINS SUPPLY INTERFERENCE/HARMONICS

A motor integral drive takes up a non-sinusoidal current from mains. A non-sinusoidal current can be transformed by means of a Fourier analysis and split up into sine wave currents with different frequencies, i.e. different harmonic currents IN with 50 Hz as the basic frequency.

Some of the harmonic currents might disturb communication equipment connected to the same transformer or cause resonance in connection with power-factor correction batteries.

To ensure low, harmonic currents, for the residential and commercial environments, an optional harmonic filter is necessary.

2.2 ELECTRICAL SPECIFICATION

2.2.1 DEPM

| Main supply (L1 L2 L3) | |
|----------------------------------|--|
| Supply frequency | 48 - 62Hz |
| Supply voltage | 3 × 200-230v ± 10%, 3 × 380-480v ± 10%, 3 × 575-600v ± 10% |
| Max. imbalance of supply voltage | 2% of rated supply |
| Switching on supply voltage | 15/ hr (Minimum 4m Interval) |
| Output ratings | |
| Output Current | 100% Drive Rated Power continuously |
| Overload Capacity | 106% of rated power |
| Digital inputs | |
| Programmable digital inputs | 2 |
| Voltage level | 0-24Vdc (user selectable NPN or PNP) |

| Analog input | |
|-------------------------------|---------|
| Programmable Analog Inputs | 2 |
| Voltage Input Mode | 0:10Vdc |
| Voltage Mode Max Voltage | 24Vdc |
| Voltage Mode Input Resistance | 10KΩ |
| Current Input Mode | 4:20mA |
| Current Mode Max Current | 20mA |
| Current Mode Max Voltage | 24Vdc |
| Current Mode Input Resistance | 500Ω |
| Resolution | 12-bit |

| Analog output | |
|-----------------|---|
| Analog output | 1 |
| Output Mode | Current, 4:20mA (the total resistance of the the load across this output shall be 500Ω) |
| Maximum Current | 20mA |
| Resolution | 12-bit |

| Digital output | |
|-----------------|---------------|
| Digital Output | 2 |
| Output Range | 0-24Vdc (NPN) |
| Maximum Current | 30mA |

| Relay output | |
|-------------------|---------------------------|
| Relay output | 2 (N.O. N.C. COM) |
| Max terminal load | 5A @ 30Vac 5A @ 250Vac |

| Externals | |
|--|---|
| Enclosure | IP55 OR IP66 |
| Vibration test | IEC 60068-2-6 |
| Max relative humidity | 95% (Non-condensing) |
| Operating ambient temperature | -10:45°C |
| Storage ambient | -25°C:60°C |
| Min. ambient temperature at full operation | -10°C |
| Altitude | 1000m without derating, de-rate 1% per 100m above 1000m |
| Maximum Altitude | 3000m |

| Compliance with Standards | |
|---------------------------|--|
| EN 61800-3:2004 | Adjustable speed electrical power drive systems. EMC requirements |
| IEC 61800-5-1 | Adjustable speed electrical drive systems - part 5-1: safety requirements - electrical, thermal and energy |
| EN 60204-1 | Safety of machinery - electrical EMC equipment of machines-part 1: general rules |

2.2.2 FRAME 71

| Main supply (L1 L2 L3) | |
|----------------------------------|--|
| Supply frequency | 48 - 62Hz |
| Supply voltage | 1 × 200-240V ± 10%, 3 × 200-230V ± 10%, 3 × 380-480V ± 10% |
| Max. imbalance of supply voltage | 2% of rated supply |
| Switching on supply voltage | 30/ hr (Minimum 2 min Interval) |

| Output ratings | |
|-------------------|-------------------------------------|
| Output Current | 100% Drive Rated Power continuously |
| Overload Capacity | 106% of rated power |

| Digital inputs | |
|-----------------------------|--------------------------------------|
| Programmable digital inputs | 2 |
| Voltage level | 0-24Vdc (user selectable NPN or PNP) |

| Analog input | |
|-------------------------------|---------|
| Programmable Analog Inputs | 2 |
| Voltage Input Mode | 0:10Vdc |
| Voltage Mode Max Voltage | 24Vdc |
| Voltage Mode Input Resistance | 240KΩ |
| Current Input Mode | 4:20mA |
| Current Mode Max Current | 20mA |
| Current Mode Max Voltage | 5Vdc |
| Current Mode Input Resistance | 180Ω |
| Resolution | 12-bit |

| Analog output | |
|------------------------------|-----------------|
| Analog output | 1 |
| Output Mode | Current, 4:20mA |
| Maximum Current | 20mA |
| Current Mode Max Voltage | 24Vdc |
| Current Mode Load Resistance | < 1 kΩ |
| Resolution | 12-bit |

| Digital output | |
|-----------------|---------------|
| Digital Output | 2 |
| Output Range | 0-24Vdc (PNP) |
| Maximum Current | 20mA |

| Relay output | |
|-------------------|---------------------------|
| Relay output | 2 (N.O. N.C. COM) |
| Max terminal load | 5A @ 30Vac 5A @ 250Vac |

| Externals | |
|--|---|
| Enclosure | IP55 OR IP66 |
| Vibration test | IEC 60068-2-6 |
| Max relative humidity | 95% (Non-condensing) |
| Operating ambient temperature | -10:40°C |
| Storage ambient | -25:60°C |
| Min. ambient temperature at full operation | -10°C |
| Altitude | 1000m without derating, de-rate 1% per 100m above 1000m |
| Maximum Altitude | 3000m |

| Compliance with Standards | |
|---------------------------|--|
| EN 61800-3:2004 | Adjustable speed electrical power drive systems. EMC requirements |
| IEC 61800-5-1 | Adjustable speed electrical drive systems - part 5-1: safety requirements - electrical, thermal and energy |
| EN 60204-1 | Safety of machinery - electrical emc equipment of machines-part 1: general rules |
| UL 61800-5-1 | Adjustable speed electrical power drive systems - part 5-1: safety requirements - electrical, thermal and energy |
| CSA C22.2#274 | Adjustable speed drives |

2.2.3 DEPM 2

| Main supply (L1 L2 L3) | |
|----------------------------------|--|
| Supply frequency | 48 - 62Hz |
| Supply voltage | 3 × 200-230V ± 10%, 3 × 380-480V ± 10%, 3 × 575-600V ± 10% |
| Max. imbalance of supply voltage | 3% of rated supply |
| Switching on supply voltage | 120/ hr (Minimum 30s Interval) |

| Output ratings | |
|-----------------------|-------------------------------------|
| Output Current | 100% Drive Rated Power continuously |
| Overload Capacity | 106% of rated power |

| Digital inputs | |
|-----------------------------|---------------|
| Programmable digital inputs | 2 |
| Voltage level | 0-24Vdc (NPN) |

| Analog input | |
|----------------------------|---------|
| Programmable Analog Inputs | 2 |
| Voltage Input Mode | 0:10Vdc |
| Voltage Mode Max Voltage | 30Vdc |
| Current Input Mode | 4:20mA |
| Current Mode Max Current | 20mA |
| Resolution | 12-bit |

| Analog output | |
|----------------------|-----------------|
| Analog output | 1 |
| Output Mode | Current, 4:20mA |
| Maximum Current | 20mA |
| Resolution | 10-bit |

| Digital output | |
|-----------------------|---------------|
| Digital Output | 1 |
| Output Range | 0-24Vdc (PNP) |
| Maximum Current | 20mA |

| Relay output | |
|-----------------------|---------------------------|
| Relay output | 2 (1×N.O. and 1×C.O.) |
| Max terminal load | 5A @ 30Vac 5A @ 250Vac |
| Optional relay output | 3×N.O. |
| Max terminal load | 5A @ 30Vac 6A @ 250Vac |

| Externals | |
|--|---|
| Enclosure | IP55 OR IP66 |
| Vibration test | IEC 60068-2-6 |
| Max relative humidity | 95% (Non-condensing) |
| Operating ambient temperature | -10:45°C |
| Storage ambient | -40:60°C |
| Min. ambient temperature at full operation | -10°C |
| Altitude | 1000m without derating, de-rate 1% per 100m above 1000m |
| Maximum Altitude | 4000m |

| Compliance with Standards | |
|----------------------------------|--|
| EN 61800-5-1:2007:A11:2021 | Adjustable speed electrical power drive systems. Safety requirements. Electrical, thermal and energy. |
| EN 61800-3:2018 | Adjustable speed electrical power drive systems. EMC requirements and specific test methods. |
| EN 60204-1:2018 | Safety of machinery. Electrical equipment of machines general requirements. Uncontrolled stop "Category 0" |
| UL 61800-5-1 | Adjustable speed electrical power drive systems - part 5-1: safety requirements - electrical, thermal and energy |
| CSA C22.2#274 | Adjustable speed drives |

2.3 ELECTRICAL INSTALLATION

2.3.1 POWER WIRING

2.3.1.1 POWER WIRING FOR FRAME 71 MOTORS - 1 PHASE

Upper right corner of the motor. Use Access port #1 for power wiring and ground.

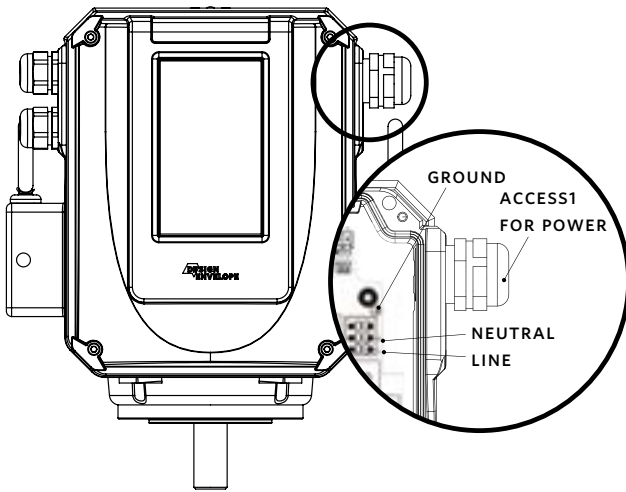

2.3.1.2 POWER WIRING FOR FRAME 71 MOTORS - 3 PHASE

Upper right corner of the motor. Use Access port #1 for power wiring and ground.

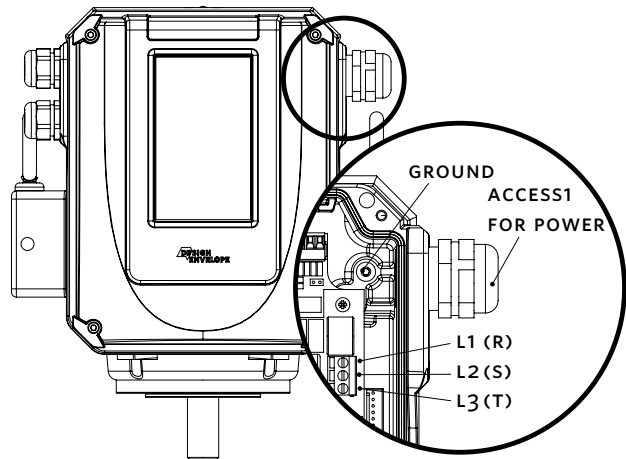

2.3.1.3 POWER WIRING FOR DEPM MOTORS

Upper right corner of the motor. Use Access port #1 for power wiring and ground.

| | | |
|------|----|-----------------|
| PIN1 | L1 | L1 power supply |
| PIN2 | L2 | L2 power supply |
| PIN3 | L3 | L3 power supply |

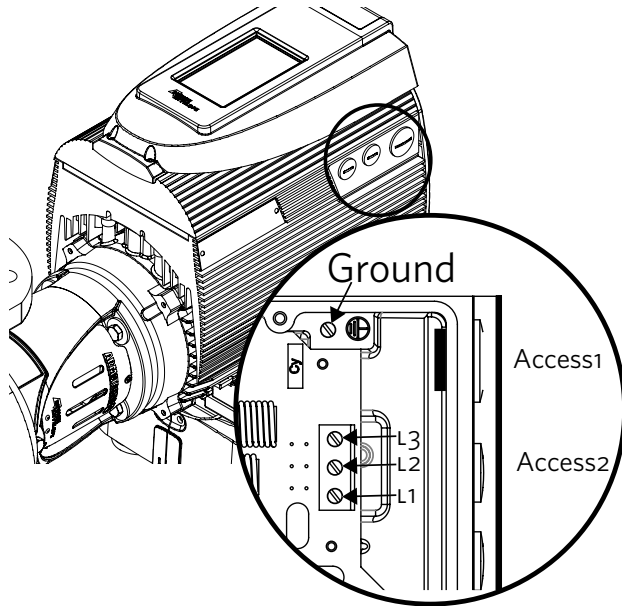

2.3.1.4 POWER WIRING FOR DEPM 2 MOTORS

Upper right corner of the motor. Use Access port #1 for power wiring and ground.

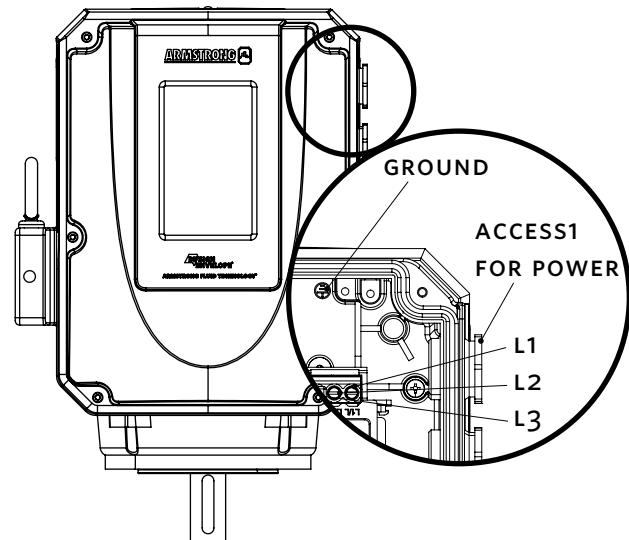

2.3.2 TOOLS YOU WILL NEED

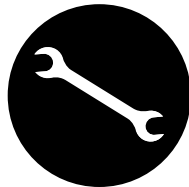

2.3.3 THE MAIN COVER DISASSEMBLY

2.3.3.1 MAIN COVER DISASSEMBLY - FRAME 71 MOTORS

1

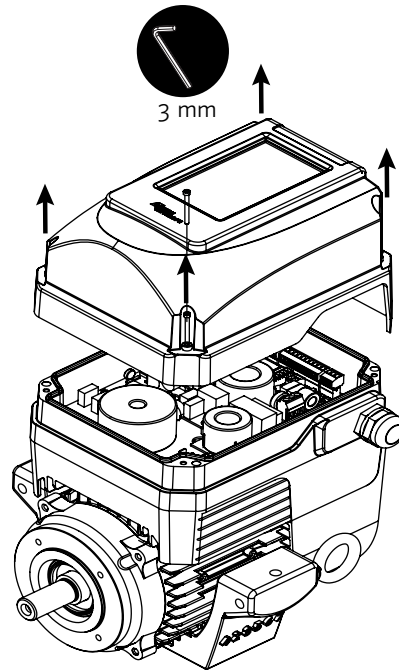

2

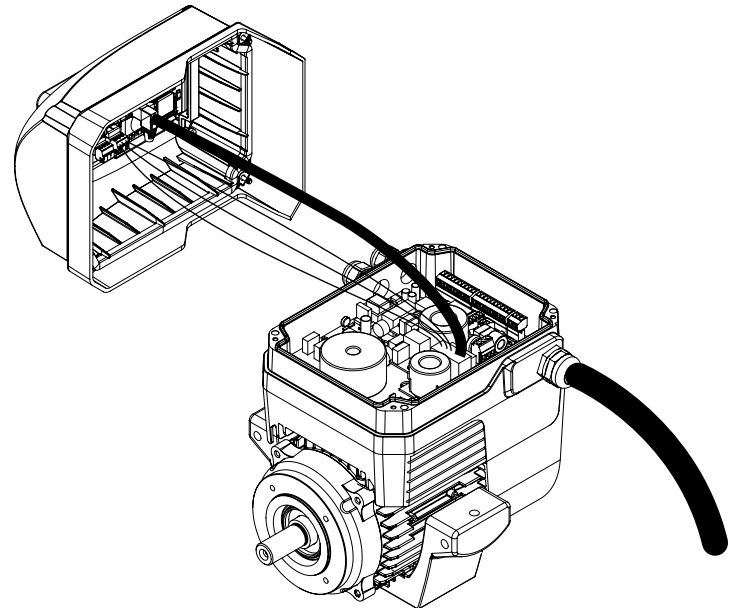

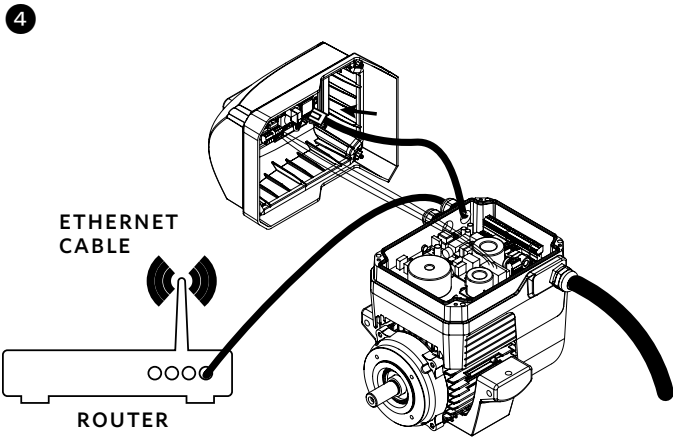
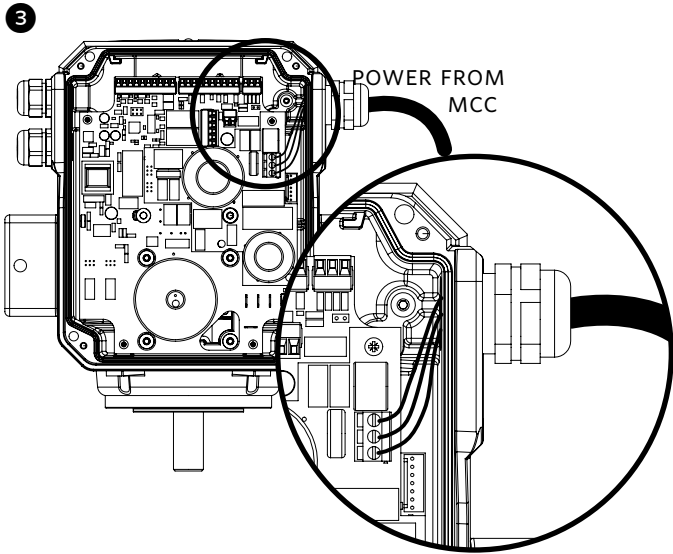

2.3.3.2 THE MAIN COVER DISASSEMBLY- DEPM

WARNING



Before removing the system must be disconnected from the mains supply. After switching off, wait for at least 4 minutes for the capacitors to discharge before opening the cover.

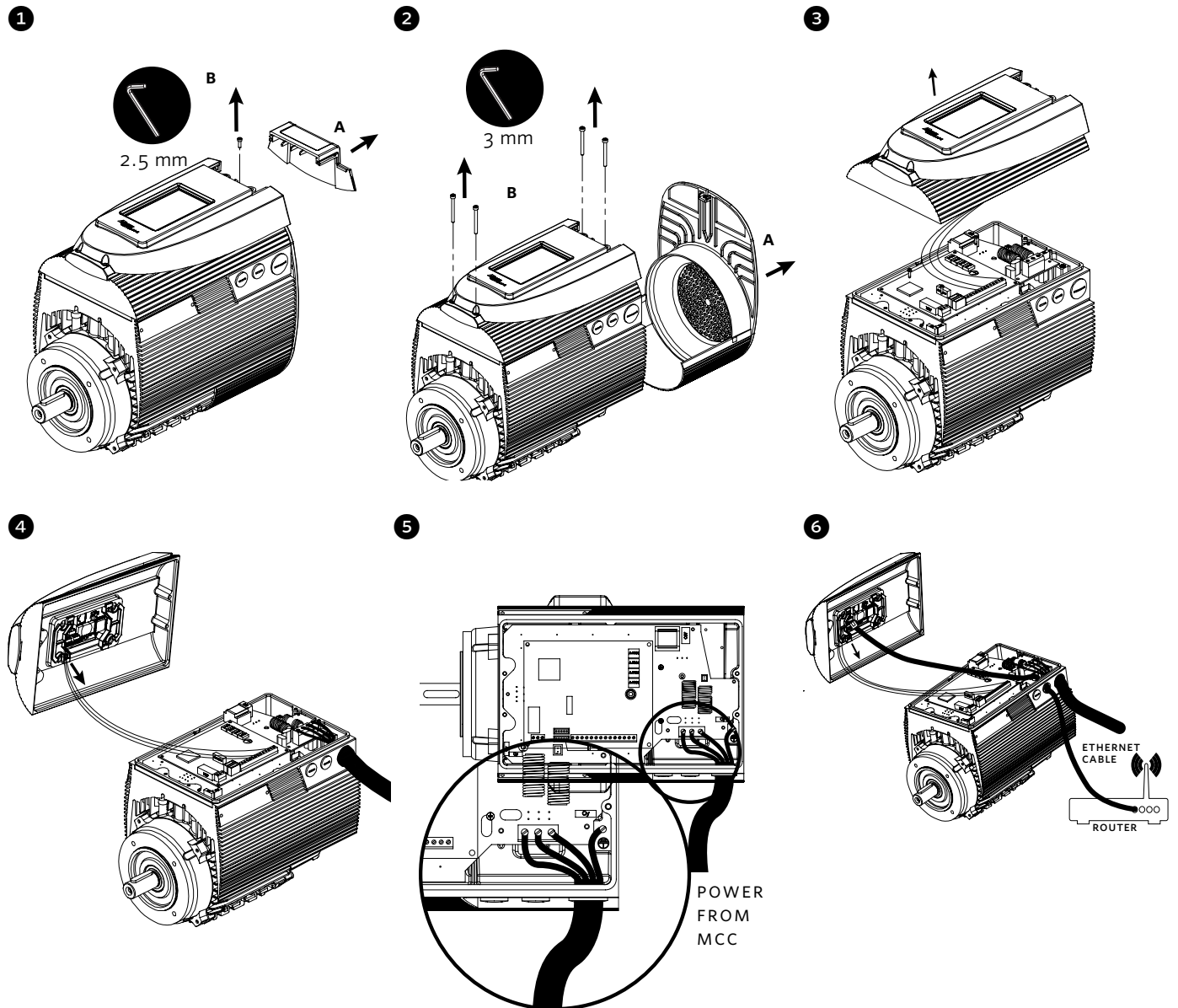

CAUTION



When you remove the front cover, pay attention to the wiring connection of the control board, unplug the connection and remove completely the cover.

2.3.3.3 THE MAIN COVER DISASSEMBLY- DEPM2

1

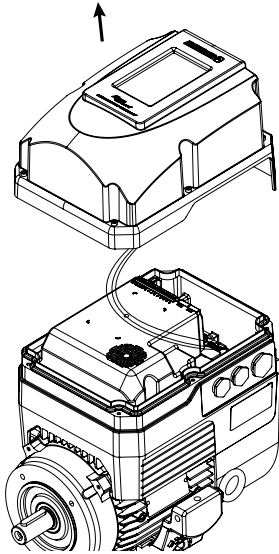

2

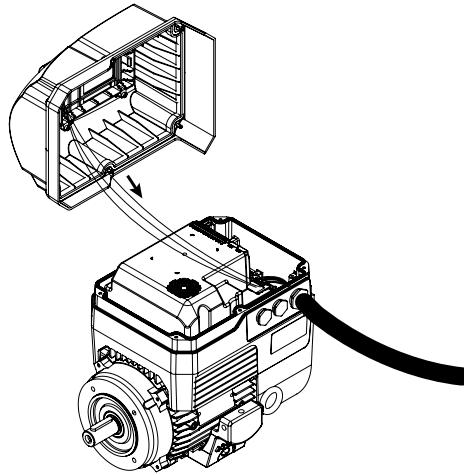

3

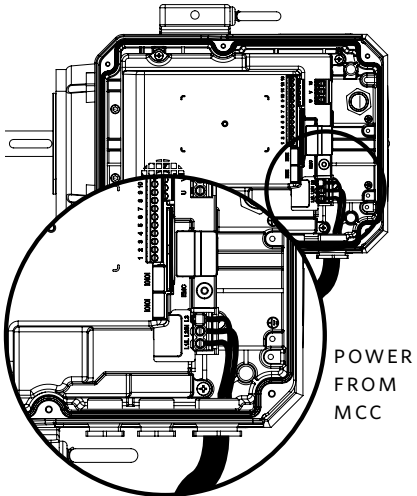

4

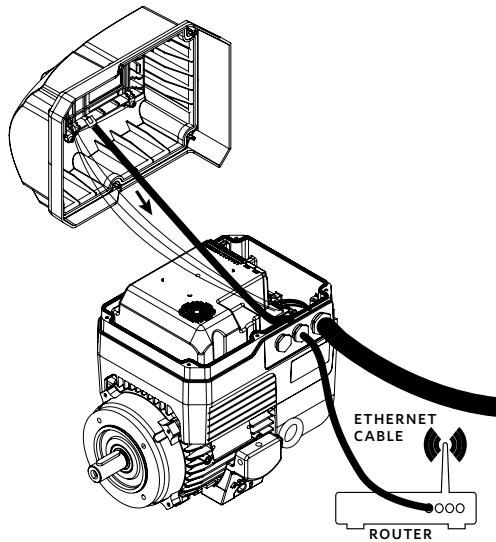

2.3.4 CONTROL TERMINAL WIRING

2.3.4.1 CONTROL TERMINAL WIRING FOR FRAME 71 MOTORS

FIG 2.3.2.A Motor Control Board

MODBUS CONNECTOR (J15)

| | |
|-------|--------------|
| Pin 1 | 485-A |
| Pin 2 | 485-B |
| Pin 3 | GND ISOLATED |

RELAYS CONNECTOR (J12)

| | |
|-------|-------------|
| Pin 1 | Relay 1 NO |
| Pin 2 | Relay 1 COM |
| Pin 3 | Relay 1 NC |
| Pin 4 | Relay 2 NO |
| Pin 5 | Relay 2 COM |
| Pin 6 | Relay 2 NC |

I/O CONNECTOR (J16-J18)

| | |
|--------|--|
| Pin 1 | +24 ISOLATED OUTPUT (200mA) |
| Pin 2 | GND ISOLATED |
| Pin 3 | +10V ISOLATED / Analog Output 4-20mA (+) |
| Pin 4 | Analog Output 4-20mA (-) |
| Pin 5 | Analog Output 0-10V |
| Pin 6 | GND ISOLATED |
| Pin 7 | +24 ISOLATED |
| Pin 8 | Digital Input 1 |
| Pin 9 | Digital Input 2 |
| Pin 10 | Comm NPN / PNP (jumper) |
| Pin 11 | GND ISOLATED |
| Pin 12 | Digital Output 1 (open collector 20mA) |
| Pin 13 | +24 ISOLATED |
| Pin 14 | Digital Output 2 (open collector 20mA) |
| Pin 15 | Analog Input 1, 4-20mA (+) |
| Pin 16 | Analog Input 1, 0-10V |
| Pin 17 | +10V ISOLATED |
| Pin 18 | GND ISOLATED |
| Pin 19 | Analog Input 2, 4-20mA (+) |
| Pin 20 | Analog Input 2, 0-10V |

2.3.4.2 CONTROL TERMINAL WIRING FOR DEPM MOTORS

FIG 2.3.2.B Motor Control Board

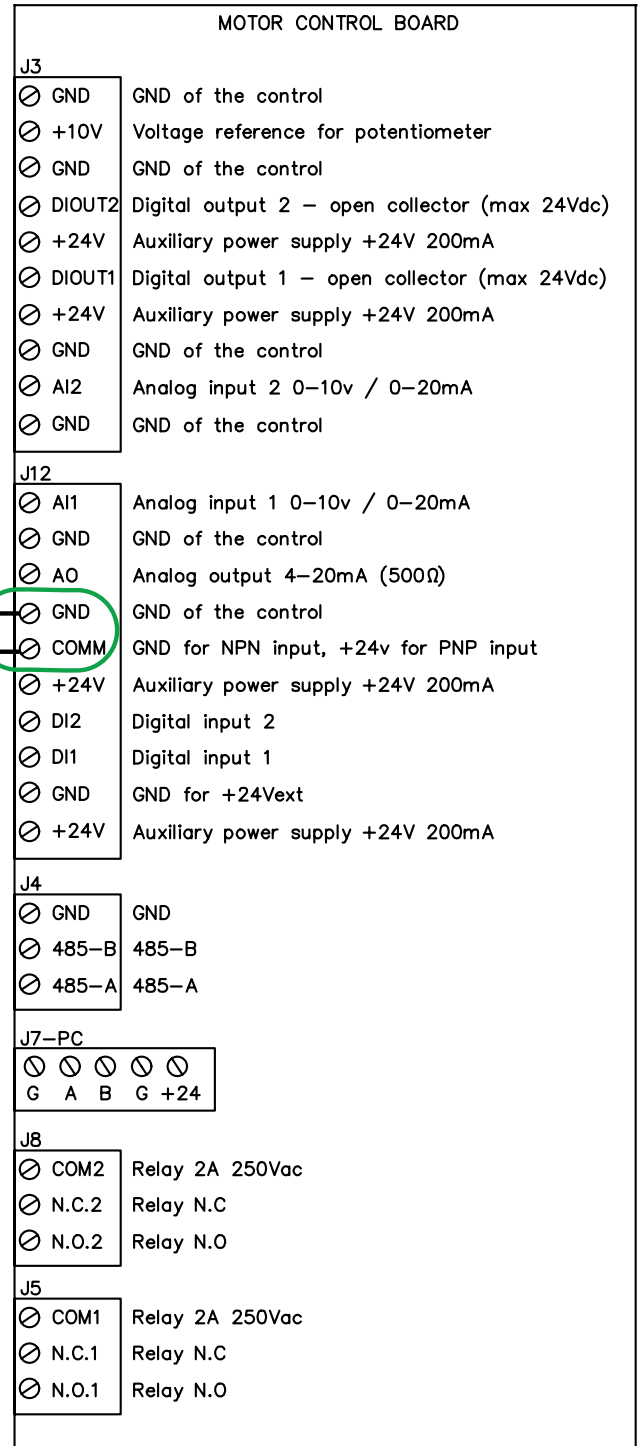

2.3.4.3 CONTROL TERMINAL WIRING FOR DEPM2 MOTORS

FIG 2.3.2.C Motor Control Board

MODBUS CONNECTOR (2x RJ-45 - Female Ports, Interchangeable)

| | |
|-------|--------------------|
| Pin 1 | NOT USED |
| Pin 2 | NOT USED |
| Pin 3 | 0 VOLT |
| Pin 4 | NOT USED |
| Pin 5 | NOT USED |
| Pin 6 | +24 VOLT |
| Pin 7 | RS 485- Modbus RTU |
| Pin 8 | RS 485+ Modbus RTU |

RELAYS CONNECTOR

| | | |
|--------|-----------|--|
| Pin 14 | RL1 - COM | Auxiliary Relay Output 1 Common |
| Pin 15 | RL1 - NO | Auxiliary Relay Output 1 Normally Open |
| Pin 16 | RL1 - NC | Auxiliary Relay Output 1 Normally Closed |
| Pin 17 | RL2 - A | Auxiliary Relay Output 2 |
| Pin 18 | RL2 - B | Auxiliary Relay Output 2 |

I/O CONNECTOR

| | | |
|--------|----------|---|
| Pin 1 | +24V DC | 24 Volt DC Output (100mA) |
| Pin 2 | DI 1 | Digital Input 1: 8-30V DC = High (30V DC Max) |
| Pin 3 | DI 2 | Digital Input 2: 8-30V DC = High (30V DC Max) |
| Pin 4 | Not Used | |
| Pin 5 | +10V DC | +10 Volt DC Output (10mA) |
| Pin 6 | AI 1 | Programmable Analog Input 1 (0-10V / 0-20mA) |
| Pin 7 | 0V / COM | 0 Volt Common for AI/AO/DI/DO |
| Pin 8 | AO | Analog Output: 4 - 20mA (20mA Max.) |
| Pin 9 | 0V / COM | 0 Volt Common for AI/AO/DI/DO |
| Pin 10 | AI 2 | Programmable Analog Input 2 (0-10V / 0-20mA) |
| Pin 11 | DO | Digital Output: 24 Volt DC (20mA Max.) when Active. |
| Pin 12 | STO+ | STO + 24V DC Connection (Run Permit). |
| Pin 13 | STO- | STO 0 Volt Connection (Run Permit). |

RELAY EXPANSION CARD (Optional Accessory)

| | | |
|-------|---------|--------------------------|
| Pin 1 | RL3 - A | Auxiliary Relay Output 3 |
| Pin 2 | RL3 - B | Auxiliary Relay Output 3 |
| Pin 3 | RL4 - A | Auxiliary Relay Output 4 |
| Pin 4 | RL4 - B | Auxiliary Relay Output 4 |
| Pin 5 | RL5 - A | Auxiliary Relay Output 5 |
| Pin 6 | RL5 - B | Auxiliary Relay Output 5 |

2.3.5 ANALOG / DIGITAL INPUTS

2.3.5.1 ANALOG / DIGITAL INPUTS FOR FRAME 71 MOTORS

I/O CONNECTOR (J16-J18)

| | |
|--------|--|
| Pin 1 | +24 ISOLATED OUTPUT (200mA) |
| Pin 2 | GND ISOLATED |
| Pin 3 | +10V ISOLATED / Analog Output 4-20mA (+) |
| Pin 4 | Analog Output 4-20mA (-) |
| Pin 5 | Analog Output 0-10V |
| Pin 6 | GND ISOLATED |
| Pin 7 | +24 ISOLATED |
| Pin 8 | Digital Input 1 |
| Pin 9 | Digital Input 2 |
| Pin 10 | Comm NPN / PNP (jumper) |
| Pin 11 | GND ISOLATED |
| Pin 12 | Digital Output 1 (open collector 20mA) |
| Pin 13 | +24 ISOLATED |
| Pin 14 | Digital Output 2 (open collector 20mA) |
| Pin 15 | Analog Input 1, 4-20mA (+) |
| Pin 16 | Analog Input 1, 0-10V |
| Pin 17 | +10V ISOLATED |
| Pin 18 | GND ISOLATED |
| Pin 19 | Analog Input 2, 4-20mA (+) |
| Pin 20 | Analog Input 2, 0-10V |

Digital Input

Wiring

Analog Input Wiring

I WIRING DIGITAL INPUTS FOR FRAME 71 MOTORS

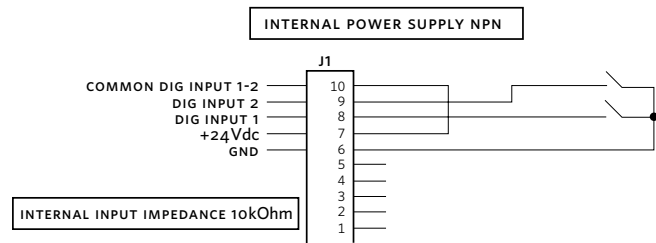

Recommended, internal NPN is default factory setting
Optional, external power supply NPN

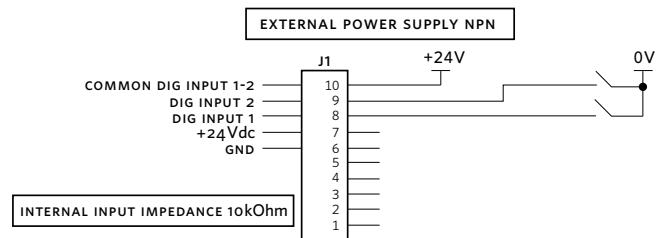

II WIRING ANALOG INPUTS FOR FRAME 71 MOTORS

0-10V INPUTS

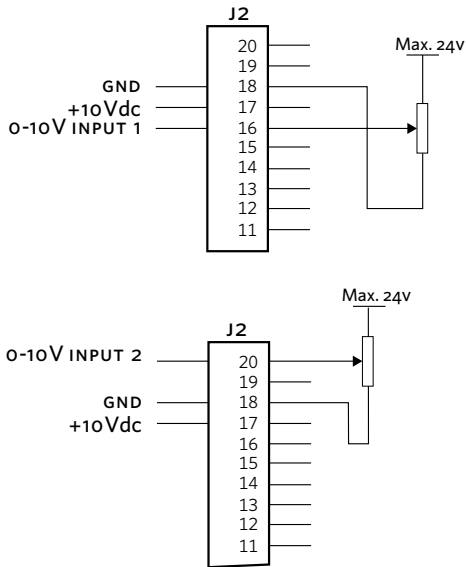

0-20mA INPUTS

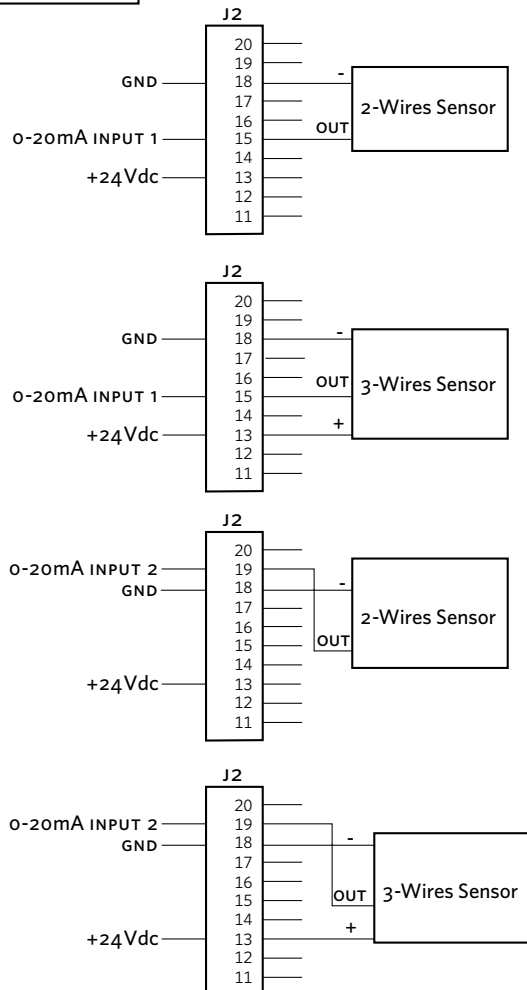

2.3.5.2 ANALOG / DIGITAL INPUTS FOR DEPM MOTORS

A WIRING

| | | |
|-----|--------|---|
| ⊗ | DIOUT1 | Digital output 1 – open collector (max 24Vdc) |
| ⊗ | +24V | Auxiliary power supply +24V 200mA |
| ⊗ | GND | GND of the control |
| ⊗ | AI2 | Analog input 2 0–10v / 0–20mA |
| ⊗ | GND | GND of the control |
| J12 | | |
| ⊗ | AI1 | Analog input 1 0–10v / 0–20mA |
| ⊗ | GND | GND of the control |
| ⊗ | A0 | Analog output 4–20mA (500Ω) |
| ⊗ | GND | GND of the control |
| ⊗ | COMM | GND for NPN input, +24v for PNP input |
| ⊗ | +24V | Auxiliary power supply +24V 200mA |
| ⊗ | DI2 | Digital input 2 |
| ⊗ | DI1 | Digital input 1 |
| ⊗ | GND | GND for +24Vext |
| ⊗ | +24V | Auxiliary power supply +24V 200mA |



The number of starts/stops via the mains voltage must not exceed one-time per minute.

If a higher number of starts/stops is required then the start/stop digital input must be used (mains voltage directly connected). This is the preferred method of starting and stopping Design Envelope Pumps.



The three phase mains must be isolated before performing maintenance of the pump.

PERSONNEL REQUIREMENTS

- 1 Armstrong Tier 3 training or equivalent
- 2 Ability to terminate simple control wiring
- 3 Ability to configure Armstrong controls
- 4 All work will be done on low voltage, however, when removing the controller cover high voltage may be exposed. An electrician license is required in some areas

I WIRING DIGITAL INPUTS

- 1 Connect one port of the contact to DIGIN1 or DIGIN2.
- 2 Connect the other port to +24VEXT

II WIRING ANALOG INPUTS

- 1 Connect signal source to ANIN1 Or ANIN2
- 2 Connect the other port to GND

2.3.5.3 ANALOG / DIGITAL INPUTS FOR DEPM2 MOTORS

FIG 2.3.5.3 - Wiring Diagram for DEPM2 Motor Inputs and Outputs

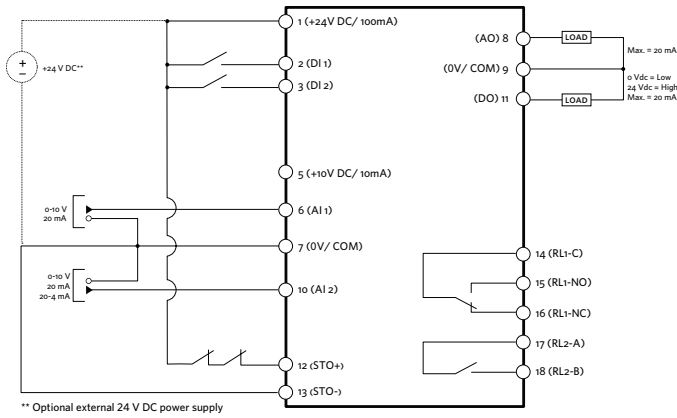

2.3.6.2 DIGITAL OUTPUT FOR FRAME 71 MOTORS

FIG 2.3.6.2

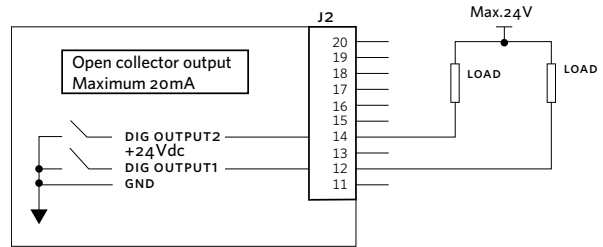

2.3.6.3 ANALOG OUTPUT FOR DEPM MOTORS

FIG 2.3.6.3

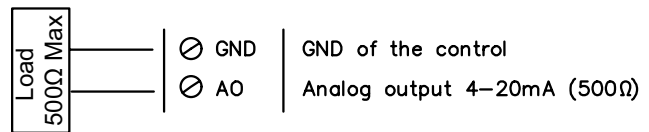

2.3.6 ANALOG / DIGITAL OUTPUT

2.3.6.1 ANALOG OUTPUT FOR FRAME 71 MOTORS

FIG 2.3.6.1

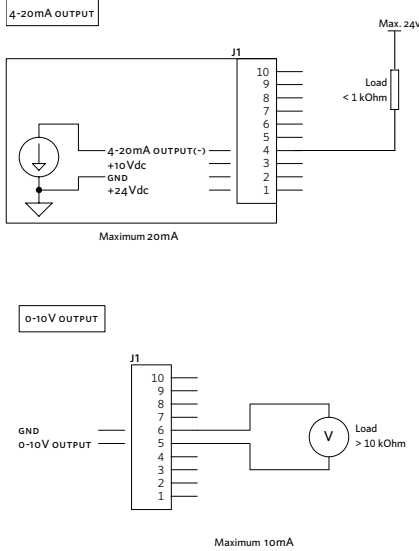

2.3.6.4 DIGITAL OUTPUT FOR DEPM MOTORS

If either of the digital outputs are to be used for voltage differential, a 500 ohm resistor (supplied by others) must be connected between the respective digital output and the 24VEXT terminal. Refer to FIG 2.3.6.4

FIG 2.3.6.4

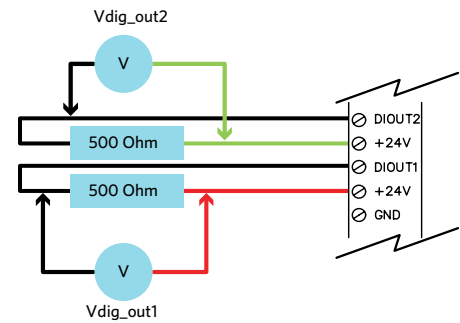

2.3.6.5 ANALOG OUTPUT FOR DEPM2 MOTORS

Refer to FIG 2.3.5.3 - Wiring Diagram for DEPM2 Motor Inputs and Outputs

2.3.6.6 DIGITAL OUTPUT FOR DEPM2 MOTORS

Refer to FIG 2.3.5.3 - Wiring Diagram for DEPM2 Motor Inputs and Outputs

| SOURCE VOLTAGE (VDC) | MAXIMUM LOAD RESISTANCE (OHM) |
|----------------------|-------------------------------|
| 5 | 150 |
| 10 | 400 |
| 24 | 1000 |

2.3.7 RELAY OUTPUT

2.3.7.1 RELAY OUTPUT FOR FRAME 71 MOTORS

Relay Connector(J12)

| | |
|-------|--------------|
| PIN 1 | Relay 1 N.O. |
| PIN 2 | Relay 1 COM |
| PIN 3 | Relay 1 N.C. |
| PIN 4 | Relay 2 N.O. |
| PIN 5 | Relay 2 COM |
| PIN 6 | Relay 2 N.C. |

2.3.7.2 RELAY OUTPUT FOR DEPM MOTORS

J5 & J8 for Relay output

| | | |
|--------------------|--------|-----------------|
| J8 Run | N.O. 2 | Relay N.O. |
| | N.C. 2 | Relay N.C. |
| | COM2 | Relay 2A 250VAC |
| J5 Alarm | N.O. 1 | Relay N.O. |
| | N.C. 1 | Relay N.C. |
| | COM 1 | Relay 2A 250VAC |

2.3.7.3 RELAY OUTPUT FOR DEPM2 MOTORS

| | |
|--------|--------------|
| PIN 14 | Relay 1 COM |
| PIN 15 | Relay 1 N.O. |
| PIN 16 | Relay 1 N.C. |
| PIN 17 | Relay 2 A |
| PIN 18 | Relay 2 B |

Max. Relay switching voltage: 250V AC/ 30V DC

Max. Relay switching current: 6A(250V AC)/5A(30V DC)

Environmental: -10°C +50°C

Terminal Torque: 0.5Nm (4.5 lb-in)

2.3.8 SUPPLY VOLTAGE

The supply voltage details can be found on the 4300 & 4380 nameplate. Please ensure that the unit is suitable for the electrical supply on which it is to be used. The mains supply for Design Envelope pumps is as follows:

1 × 200-240V ± 10%,

3 × 200-230V ± 10%,

3 × 380-480V ± 10%,

3 × 575-600V ± 10%

Frequency - 50/60Hz

2.3.9 SUPPLY FUSING

Branch circuit protection

in order to protect the installation against electrical and fire hazard, all branch circuits in an installation, switch gear, machines etc., must be short-circuit and over-current protected according to the national/international regulations. Please refer to **SECTION 8.0** (Fuse and wire recommendation).

Short circuit protection

The inverter must be protected against short-circuit to avoid electrical or fire hazard. The frequency converter provides full short circuit protection in case of a short-circuit on the motor output.

2.4 DESIGN ENVELOPE PUMP CONTROLLER WIRING

FIG 2.4 Controller Board

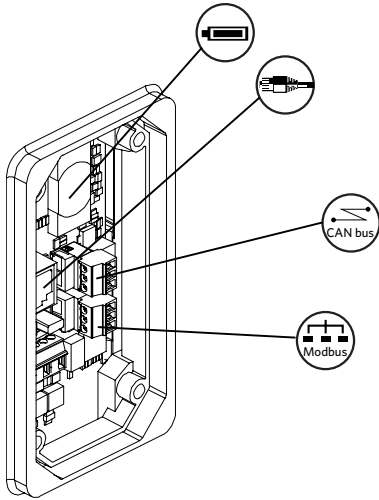
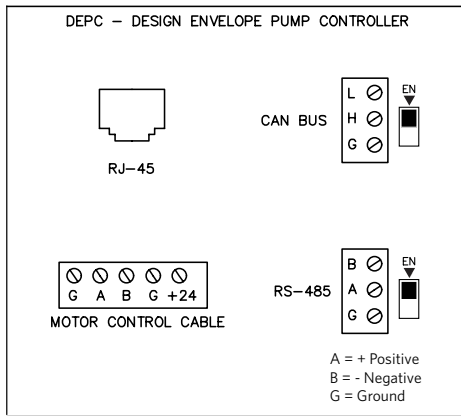

FIG 2.4A



2.4.1 BATTERY

The battery is used to power the real-time clock whenever the pump is disconnected from mains power. It is recommended the battery be changed every 2 to 3 years.

2.4.2 ETHERNET CONNECTIVITY

For a BACnet IP or Modbus TCP connection to a building automation system (BAS), connect the network cable to the RJ-45 port, as shown in FIG. 2.4A

2.4.3 CAN BUS WIRING

The CAN bus port on the DEPC has terminals for the following signal connections: High, Low, and Ground, as shown in FIG. 2.4A. If multiple pumps are connected in parallel for CAN BUS (supplied by others) they should be daisy chained together. Ensure that only the first and last terminating resistor switches are set to Enabled.

2.4.4 RS 485 WIRING

For a BACnet MS/TP or Modbus RTU connection to a building automation system, connect the network cable to the RS-485 port, as shown in FIG. 2.4A. When the DEPC is at the end of the RS-485 network, ensure that the terminating resistor is Enabled by setting the corresponding switch to the EN position.

If multiple pumps are connected to the BAS, ensure that only the first and last terminating resistor switches are set to Enabled. See example below in FIG 2.4.1

FIG 2.4.1

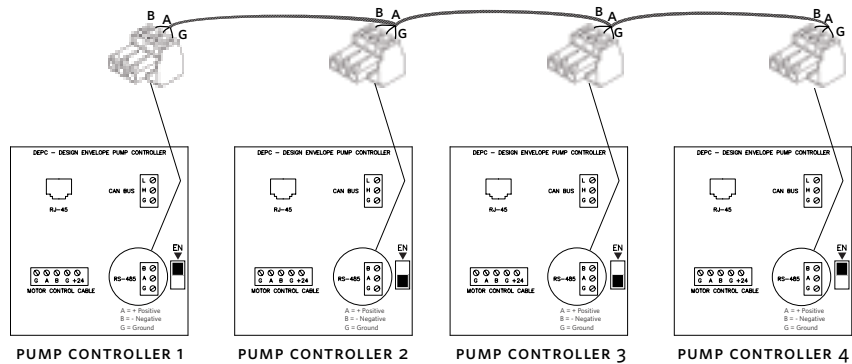

2.4.5 NETWORKING OPTIONS

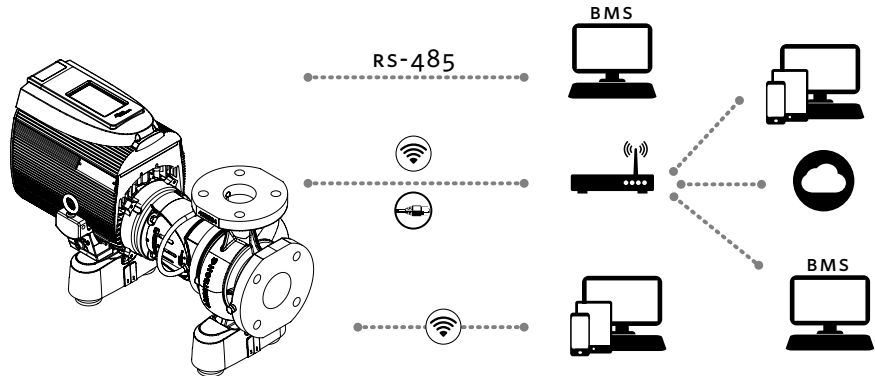

3.0 NETWORKING CONTROLS

For connection to the building automation system (BAS), the pump needs to be properly configured to the network. Ensure the RS485 cable is connected to the controller board (FIG. 2.4). Or if connecting to the bas via router, ensure that the RJ-45 cable is connected to the controller board (FIG. 2.4).

The pump controls can be configured from the touchscreen or the webserver.



For BACNet MS/TP or TCP/IP: Enter the BACNet address, baud rate, and unique device instance number (as applicable)

For Modbus RTU or TCP/IP: Enter the Modbus address, baud rate, and parity stop bits (as applicable)

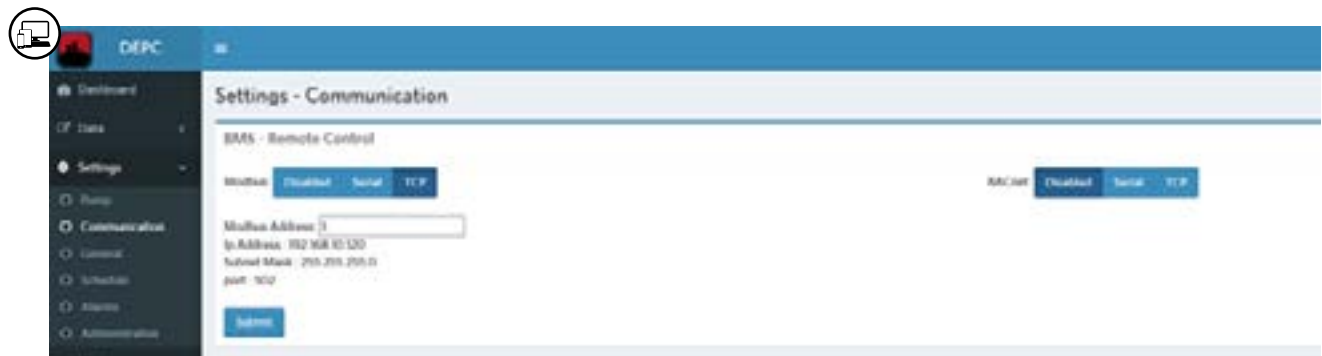

3.1 MODBUS REGISTER MAP - VERSION 1 - FOR FIRMWARE V1.16 AND OLDER

| FUNCTION CODE | | START ADDRESS | MODBUS REGISTER | DESCRIPTION | # OF REGISTERS | CHANGE DURING OPERATION | DATA TYPE | UNIT | NOTES |
|-----------------|-------|---------------|-----------------|----------------------------------|----------------|-------------------------|-----------|-----------------|---|
| READ | WRITE | | | | | | | | |
| 0x03 | 0x06 | | | | | | | | |
| Status | | | | | | | | | |
| x | | 100 | 101 | Actual Speed | 1 | N/A | UINT16 | 1 RPM | The current speed of the vfd in RPM. |
| x | | 101 | 102 | Actual Speed | 1 | N/A | UINT16 | 0.1 % | The current speed of the vfd in % of the nominal motor speed. |
| x | | 102 | 103 | Motor Power | 2 | N/A | UINT32 | 0.01 | Units as configured on Pump Control Module. |
| x | | 104 | 105 | Motor Input Voltage | 1 | N/A | UINT16 | 0.1 V | Voltage delivered by the vsd to the motor. |
| x | | 105 | 106 | Motor Input Current | 2 | N/A | UINT32 | 0.01 A | Current delivered by the vsd to the motor. |
| x | | 107 | 108 | Sensorless Head | 2 | N/A | UINT32 | 0.01 | Units as configured on Pump Control Module. |
| x | | 109 | 110 | Sensorless Flow | 2 | N/A | UINT32 | 0.01 | Units as configured on Pump Control Module. |
| x | | 111 | 112 | Total Flow | 2 | N/A | UINT32 | 0.01 | Used for Parallel sensorless mode |
| x | | 113 | 114 | Total Power | 2 | N/A | UINT32 | 0.01 | Used for Parallel sensorless mode |
| x | | 115 | 116 | Number of Running Pumps | 1 | N/A | UINT16 | - | Used for Parallel sensorless mode |
| x | | 116 | 117 | Max Sensorless Flow | 2 | N/A | UINT32 | 0.01 | Units as configured on Pump Control Module. |
| x | | 118 | 119 | Max Sensorless Head | 2 | N/A | UINT32 | 0.01 | Units as configured on Pump Control Module. |
| x | | 122 | 123 | Status | 1 | N/A | UINT16 | - | Bit: 0 = pump run status (0=not rotating, 1=rotating) |
| I/O | | | | | | | | | |
| x | | 200 | 201 | Digital In | 1 | N/A | UINT16 | - | Digital input 1 is bit 0 and input 2 is bit 1. |
| x | | 201 | 202 | Analog In 1 | 2 | N/A | UINT32 | 0.01 V, 0.01 mA | Units as configured on Pump Control Module |
| x | | 203 | 204 | Analog In 2 | 2 | N/A | UINT32 | 0.01 V, 0.01 mA | Units as configured on Pump Control Module |
| x | | 205 | 206 | Analog Out 1 | 1 | N/A | UINT16 | 0.01 mA | |
| x | | 206 | 207 | Digital Out | 1 | N/A | UINT16 | - | Digital output 1 is bit 0 and output 2 is bit 1. |
| x | | 207 | 208 | Relays | 1 | N/A | UINT16 | - | Relay 1 is bit 0 and relay 2 is bit 1. |
| Units | | | | | | | | | |
| x | | 250 | 251 | Flow Units | 1 | N/A | UINT16 | - | 1 = l/s; 2 = m ³ /h; 3 = g/m |
| x | | 251 | 252 | Pressure Units | 1 | N/A | UINT16 | - | 1 = bar; 2 = kPa; 3 = psi; 4 = ft; 5 = m |
| x | | 252 | 253 | Power Units | 1 | N/A | UINT16 | - | 1 = kw; 2 = hp |
| x | | 253 | 254 | Speed Units | 1 | N/A | UINT16 | - | 1 = RPM; 2 = % |
| x | | 254 | 255 | Temperature Units | 1 | N/A | UINT16 | - | 1 = Degrees Celsius; 2 = Degrees Fahrenheit |
| Counters | | | | | | | | | |
| x | | 275 | 276 | Total Pump Running Hours | 2 | N/A | UINT32 | 1 h | |
| x | x | 277 | 278 | Trip Pump Running Hours | 2 | N/A | UINT32 | 1 h | Writing 0 to this register resets the counter. |
| x | | 279 | 280 | Total Controller Running Hours | 2 | N/A | UINT32 | 1 h | |
| x | | 281 | 282 | Present Controller Running Hours | 2 | N/A | UINT32 | 1 h | The running hours since the controller was powered on. |
| x | | 283 | 284 | Total Pump Running kWh Counter | 2 | N/A | UINT32 | 1 kWh | |
| x | x | 285 | 286 | Trip Pump Running kWh Counter | 2 | N/A | UINT32 | 1 kWh | Writing 0 to this register rests the counter. |

| FUNCTION CODE | | START ADDRESS | MODBUS REGISTER | DESCRIPTION | # OF REGISTERS | CHANGE DURING OPERATION | DATA TYPE | UNIT | NOTES |
|----------------------------|-------|---------------|-----------------|--------------------------------|----------------|-------------------------|-----------|-------|--|
| READ | WRITE | | | | | | | | |
| 0x03 | 0x06 | | | | | | | | |
| Control Settings | | | | | | | | | |
| x | | 300 | 301 | Control Mode | 1 | Yes | UINT16 | - | 1 = Parallel; 2 = Inputs; 3 = Remote; 4 = Constant Flow; 5 = Constant Pressure; 6 = Linear Pressure; 7 = Quadratic Pressure; 8 = Quad Pressure Maximum; 9 = Quad Pressure Minimum; 10 = Quadratic Pressure Max/Min |
| x | x | 301 | 302 | HOA State | 1 | Yes | UINT16 | - | 0 = Off; 1 = Hand; 2 = Auto |
| x | x | 302 | 303 | Active Parameters | 1 | Yes | UINT16 | - | 1 = standard; 2 = mode 1 (heating mode); 3 = mode 2 (cooling mode) |
| x | x | 303 | 304 | Minimum Speed Limit | 1 | Yes | UINT16 | 0.1 | In RPM |
| x | x | 304 | 305 | Maximum Speed Limit | 1 | Yes | UINT16 | 1 | In RPM. |
| x | x | 305 | 306 | Hand Mode Speed | 1 | Yes | UINT16 | 0.1 | Units as configured on Pump Control Module. |
| x | x | 306 | 307 | BMS Set Speed | 1 | Yes | UINT16 | 0.1 | Units as configured on Pump Control Module. |
| Alarms and Warnings | | | | | | | | | |
| x | | 400 | 401 | Alarms | 2 | N/A | UINT32 | - | Refer to Alarms Table for Bit Positions |
| x | | 402 | 403 | Warnings | 2 | N/A | UINT32 | - | Refer to warnings table for Bit Positions |
| | x | 404 | 405 | Acknowledge Warnings | 2 | Yes | UINT32 | - | 32-bit field corresponding to the warning field |
| Parameters | | | | | | | | | |
| x | | 500 | 501 | Standard Mode - Zero Flow Head | 2 | Yes | UINT32 | 0.01 | Value for standard active mode. Units as configured on Pump Control Module. |
| x | | 502 | 503 | Standard Mode - Design Head | 2 | Yes | UINT32 | 0.01 | Value for standard active mode. Units as configured on Pump Control Module. |
| x | | 504 | 505 | Standard Mode - Design Flow | 2 | Yes | UINT32 | 0.01 | Value for standard active mode. Units as configured on Pump Control Module. |
| x | | 506 | 507 | Standard Mode - Minimum Flow | 2 | Yes | UINT32 | 0.01 | Value for standard active mode. Units as configured on Pump Control Module. |
| x | | 508 | 509 | Mode 1 - Zero Flow Head | 2 | Yes | UINT32 | 0.01 | Value for active mode 1. Units as configured on Pump Control Module. |
| x | | 510 | 511 | Mode 1 - Design Head | 2 | Yes | UINT32 | 0.01 | Value for active mode 1. Units as configured on Pump Control Module. |
| x | | 512 | 513 | Mode 1 - Design Flow | 2 | Yes | UINT32 | 0.01 | Value for active mode 1. Units as configured on Pump Control Module. |
| x | | 514 | 515 | Mode 1 - Minimum Flow | 2 | Yes | UINT32 | 0.01 | Value for active mode 1. Units as configured on Pump Control Module. |
| x | | 516 | 517 | Mode 2 - Zero Flow Head | 2 | Yes | UINT32 | 0.01 | Value for active mode 2. Units as configured on Pump Control Module. |
| x | | 518 | 519 | Mode 2 - Design Head | 2 | Yes | UINT32 | 0.01 | Value for active mode 2. Units as configured on Pump Control Module. |
| x | | 520 | 521 | Mode 2 - Design Flow | 2 | Yes | UINT32 | 0.01 | Value for active mode 2. Units as configured on Pump Control Module. |
| x | | 522 | 523 | Mode 2 - Minimum Flow | 2 | Yes | UINT32 | 0.01 | Value for active mode 2. Units as configured on Pump Control Module. |
| Information | | | | | | | | | |
| x | | 900 | 901 | Pump Name / Tag name | 8 | N/A | ASCII | - | The pump name as a series of ASCII characters. |
| x | | 908 | 909 | Serial Number | 7 | N/A | ASCII | - | Serial No. of the Pump represented by ASCII characters |
| x | | 915 | 916 | Firmware Version | 1 | N/A | UINT16 | 00.00 | Divide the number by 100 to get the major. minor version of the DEPC. |
| x | | 916 | 917 | Hardware Version | 1 | N/A | UINT16 | - | The Pump Control Module hardware version. |
| x | | 917 | 918 | Modbus Version | 1 | N/A | UINT16 | - | Version of the Armstrong Modbus version |

3.2 BACNET OBJECTS - VERSION 1 - FOR FIRMWARE V1.16 AND OLDER

| OBJECT ID | OBJECT NAME | READ/WRITE | COMMENTS |
|----------------------------|----------------------------------|------------|--|
| Status | | | |
| AV:100 | Actual Speed | Read | In RPM |
| AV:101 | Actual speed | Read | In % |
| AV:102 | Motor Power | Read | Unit as configured in Pump Control Module |
| AV:103 | Motor Input Voltage | Read | In Volts |
| AV:104 | Motor Input Current | Read | In Amps |
| AV:105 | Sensorless Head | Read | Unit as configured in Pump Control Module |
| AV:106 | Sensorless Flow | Read | Unit as configured in Pump Control Module |
| AV:107 | Total Flow | Read | Used for Parallel sensorless mode |
| AV:108 | Total Power | Read | Used for Parallel sensorless mode |
| AV:109 | No. Of Running Pumps | Read | Used for Parallel sensorless mode |
| AV:110 | Max Sensorless Flow | Read | Unit as configured in Pump Control Module |
| AV:111 | Max Sensorless Head | Read | Unit as configured in Pump Control Module |
| BV:2 | Run Status | Read | 1 → pump is running |
| Counters | | | |
| AV:275 | Total Pump Running Hours | Read | |
| AV:276 | Trip Pump Running Hours | Read/Write | Writing 0 to this register resets the counter. |
| AV:277 | Total Controller Running Hours | Read | |
| AV:278 | Present Controller Running Hours | Read | The running hours since the controller was powered on. |
| AV:279 | Total Pump Running kWh Counter | Read | |
| AV:280 | Trip Pump Running kWh Counter | Read/Write | Writing 0 to this register resets the counter. |
| Control Settings | | | |
| AV:300 | Control Mode | Read | 1 = Parallel; 2 = Inputs; 3 = Remote; 4 = Constant Flow; 5 = Constant Pressure; 6 = Linear Pressure; 7 = Quadratic Pressure; 8 = Quadratic Pressure with Maximum Flow; 9 = Quadratic Pressure with Minimum Flow; 10 = Quadratic Pressure with Minimum and Maximum Flow |
| AV:301 | HOA State | Read/Write | 0 = OFF; 1 = Hand Mode; 2 = Auto |
| AV:302 | Active Parameters | Read/Write | 1 = standard; 2 = mode 1 (heating mode); 3 = mode 2 (cooling mode) |
| AV:303 | Minimum Speed Limit | Read | in RPM |
| AV:304 | Maximum Speed Limit | Read | in RPM |
| AV:305 | Hand Mode Speed | Read/Write | Unit as configured in Pump Control Module. |
| AV:306 | BMS Set Speed | Read/Write | Unit as configured in Pump Control Module. |
| Alarms and Warnings | | | |
| AV:400 | Alarms | Read | Refer to Alarms Table for Bit Positions |
| AV:401 | Warnings | Read | Refer to Warnings Table for Bit Positions |
| AV:402 | Acknowledge Warnings | Write | 32-bit field corresponding to the warning field |

| OBJECT ID | OBJECT NAME | READ/WRITE | COMMENTS |
|-------------------|--------------------------------|------------|---|
| Parameters | | | |
| AV:500 | Standard Mode - Zero Flow Head | Read | Value for standard active mode. Unit as configured in Pump Control Module |
| AV:501 | Standard Mode - Design Head | Read | Value for standard active mode. Unit as configured in Pump Control Module |
| AV:502 | Standard Mode - Design Flow | Read | Value for standard active mode. Unit as configured in Pump Control Module |
| AV:503 | Standard Mode - Minimum Flow | Read | Value for standard active mode. Unit as configured in Pump Control Module |
| AV:504 | Mode 1 - Zero Flow Head | Read | Value for active mode 1. Unit as configured in Pump Control Module |
| AV:505 | Mode 1 - Design Head | Read | Value for active mode 1. Unit as configured in Pump Control Module |
| AV:506 | Mode 1 - Design Flow | Read | Value for active mode 1. Unit as configured in Pump Control Module |
| AV:507 | Mode 1 - Minimum Flow | Read | Value for active mode 1. Unit as configured in Pump Control Module |
| AV:508 | Mode 2 - Zero Flow Head | Read | Value for active mode 2. Unit as configured in Pump Control Module |
| AV:509 | Mode 2 - Design Head | Read | Value for active mode 2. Unit as configured in Pump Control Module |
| AV:510 | Mode 2 - Design Flow | Read | Value for active mode 2. Unit as configured in Pump Control Module |
| AV:511 | Mode 2 - Minimum Flow | Read | Value for active mode 2. Unit as configured in Pump Control Module |
| I/O | | | |
| AI:0 | Analog In 1 | Read | As configured in Pump Control Module |
| AI:1 | Analog In 2 | Read | As configured in Pump Control Module |
| AO:0 | Analog Out 1 | Read | As configured in Pump Control Module |
| BI:0 | Digital In:1 | Read | As configured in Pump Control Module |
| BI:1 | Digital In:2 | Read | As configured in Pump Control Module |
| BO:0 | Digital Out:1 | Read | As configured in Pump Control Module |
| BO:1 | Digital Out:2 | Read | As configured in Pump Control Module |
| BV:0 | Relay 1 | Read | As configured in Pump Control Module |
| BV:1 | Relay 2 | Read | As configured in Pump Control Module |

3.3 MODBUS REGISTER MAP - VERSION 2 - FOR FIRMWARE V1.17 AND NEWER

| FUNCTION CODE | | START ADDRESS | MODBUS REGISTER | DESCRIPTION | # OF REGISTERS | CHANGE DURING OPERATION | DATA TYPE | UNIT | NOTES |
|-----------------|-------|---------------|-----------------|----------------------------------|----------------|-------------------------|-----------|--------------------|---|
| READ | WRITE | | | | | | | | |
| 0x03 | 0x06 | | | | | | | | |
| Status | | | | | | | | | |
| x | | 100 | 101 | Actual Speed | 1 | N/A | UINT16 | 1 RPM | The current speed of the VFD in RPM. |
| x | | 101 | 102 | Actual Speed | 1 | N/A | UINT16 | 0.1 % | The current speed of the VFD in % of the nominal motor speed. |
| x | | 102 | 103 | Motor Power | 2 | N/A | UINT32 | 0.01 | Units as configured on Pump Control Module. |
| x | | 104 | 105 | Motor Input Voltage | 1 | N/A | UINT16 | 0.1 V | Voltage delivered by the VSD to the motor. |
| x | | 105 | 106 | Motor Input Current | 2 | N/A | UINT32 | 0.01 A | Current delivered by the VSD to the motor. |
| x | | 107 | 108 | Sensorless Head | 2 | N/A | UINT32 | 0.01 | Units as configured on Pump Control Module. |
| x | | 109 | 110 | Sensorless Flow | 2 | N/A | UINT32 | 0.01 | Units as configured on Pump Control Module. |
| x | | 111 | 112 | Total Flow | 2 | N/A | UINT32 | 0.01 | Used for Parallel sensorless mode |
| x | | 113 | 114 | Total Power | 2 | N/A | UINT32 | 0.01 | Used for Parallel sensorless mode |
| x | | 115 | 116 | Number of Running Pumps | 1 | N/A | UINT16 | - | Used for Parallel sensorless mode |
| x | | 116 | 117 | Max Sensorless Flow | 2 | N/A | UINT32 | 0.01 | Units as configured on Pump Control Module. |
| x | | 118 | 119 | Max Sensorless Head | 2 | N/A | UINT32 | 0.01 | Units as configured on Pump Control Module. |
| x | | 122 | 123 | Status | 1 | N/A | UINT16 | - | Bit:0 = pump run status (0=not rotating, 1=rotating) |
| I/O | | | | | | | | | |
| x | | 200 | 201 | Digital In | 1 | N/A | UINT16 | - | Digital input 1 is bit 0 and input 2 is bit 1. |
| x | | 201 | 202 | Analog In 1 | 2 | N/A | UINT32 | 0.01 V, 0.01 mA | Units as configured on Pump Control Module |
| x | | 203 | 204 | Analog In 2 | 2 | N/A | UINT32 | 0.01 V, 0.01 mA | Units as configured on Pump Control Module |
| x | | 205 | 206 | Analog Out 1 | 1 | N/A | UINT16 | 0.01 mA | |
| x | | 206 | 207 | Digital Out | 1 | N/A | UINT16 | - | Digital output 1 is bit 0 and output 2 is bit 1. |
| x | | 207 | 208 | Relays | 1 | N/A | UINT16 | - | Relay 1 is bit 0 and relay 2 is bit 1. |
| Units | | | | | | | | | |
| x | | 250 | 251 | Flow Units | 1 | N/A | UINT16 | - | 1 = l/s; 2 = m ³ /h; 3 = g/m |
| x | | 251 | 252 | Pressure Units | 1 | N/A | UINT16 | - | 1 = bar; 2 = kPa; 3 = psi; 4 = ft; 5 = m |
| x | | 252 | 253 | Power Units | 1 | N/A | UINT16 | - | 1 = kw; 2 = hp |
| x | | 253 | 254 | Speed Units | 1 | N/A | UINT16 | - | 1 = RPM; 2 = % |
| x | | 254 | 255 | Temperature Units | 1 | N/A | UINT16 | - | 1 = Degrees Celsius; 2 = Degrees Fahrenheit |
| Counters | | | | | | | | | |
| x | | 275 | 276 | Total Pump Running Hours | 2 | N/A | UINT32 | 1 h | |
| x | x | 277 | 278 | Trip Pump Running Hours | 2 | N/A | UINT32 | 1 h | Writing 0 to this register resets the counter. |
| x | | 279 | 280 | Total Controller Running Hours | 2 | N/A | UINT32 | 1 h | |
| x | | 281 | 282 | Present Controller Running Hours | 2 | N/A | UINT32 | 1 h | The running hours since the controller was powered on. |
| x | | 283 | 284 | Total Pump Running kWh Counter | 2 | N/A | UINT32 | 1 kWh | |
| x | x | 285 | 286 | Trip Pump Running kWh Counter | 2 | N/A | UINT32 | 1 kWh | Writing 0 to this register rests the counter. |

| FUNCTION CODE | | START ADDRESS | MODBUS REGISTER | DESCRIPTION | # OF REGISTERS | CHANGE DURING OPERATION | DATA TYPE | UNIT | NOTES |
|---------------|-------|---------------|-----------------|-------------|----------------|-------------------------|-----------|------|-------|
| READ | WRITE | | | | | | | | |
| 0x03 | 0x06 | | | | | | | | |

Control Settings

| | | | | | | | | | |
|---|---|-----|-----|---------------------|---|-----|--------|-----|--|
| x | | 300 | 301 | Control Mode | 1 | Yes | UINT16 | - | 1 = Parallel; 2 = Inputs; 3 = Remote; 4 = Constant Flow; 5 = Constant Pressure; 6 = Linear Pressure; 7 = Quadratic Pressure; 8 = Quad Pressure Maximum; 9 = Quad Pressure Minimum; 10 = Quadratic Pressure Max/Min |
| x | x | 301 | 302 | HOA State | 1 | Yes | UINT16 | - | 0 = Off; 1 = Hand; 2 = Auto |
| x | x | 302 | 303 | Active Parameters | 1 | Yes | UINT16 | - | 1 = standard; 2 = mode 1 (heating mode); 3 = mode 2 (cooling mode) |
| x | x | 303 | 304 | Minimum Speed Limit | 1 | Yes | UINT16 | 1 | In RPM |
| x | x | 304 | 305 | Maximum Speed Limit | 1 | Yes | UINT16 | 1 | In RPM. |
| x | x | 305 | 306 | Hand Mode Speed | 1 | Yes | UINT16 | 0.1 | Units as configured on Pump Control Module. |
| x | x | 306 | 307 | BMS Set Speed | 1 | Yes | UINT16 | 0.1 | Units as configured on Pump Control Module. |
| x | x | 308 | 309 | Start/Stop | 1 | Yes | UINT16 | - | 0 = stop pump; 1 = start pump |

Alarms and Warnings

| | | | | | | | | | |
|---|---|-----|-----|----------------------|---|-----|--------|---|--|
| x | | 400 | 401 | Alarms | 2 | N/A | UINT32 | - | Refer to alarms table for bit positions. |
| x | | 402 | 403 | Warnings | 2 | N/A | UINT32 | - | Refer to warnings table for bit positions. |
| x | x | 404 | 405 | Acknowledge Warnings | 2 | Yes | UINT32 | - | 32-bit field corresponding to the warning field. |

Parameters

| | | | | | | | | | |
|---|---|-----|-----|--------------------------------|---|-----|--------|------|--|
| x | | 500 | 501 | Standard Mode - Zero Flow Head | 2 | Yes | UINT32 | 0.01 | Value for standard active mode. Units as configured on Pump Control Module. |
| x | | 502 | 503 | Standard Mode - Design Head | 2 | Yes | UINT32 | 0.01 | Value for standard active mode. Units as configured on Pump Control Module. |
| x | | 504 | 505 | Standard Mode - Design Flow | 2 | Yes | UINT32 | 0.01 | Value for standard active mode. Units as configured on Pump Control Module. |
| x | | 506 | 507 | Standard Mode - Minimum Flow | 2 | Yes | UINT32 | 0.01 | Value for standard active mode. Units as configured on Pump Control Module. |
| x | | 508 | 509 | Mode 1 - Zero Flow Head | 2 | Yes | UINT32 | 0.01 | Value for active mode 1. Units as configured on Pump Control Module. |
| x | | 510 | 511 | Mode 1 - Design Head | 2 | Yes | UINT32 | 0.01 | Value for active mode 1. Units as configured on Pump Control Module. |
| x | | 512 | 513 | Mode 1 - Design Flow | 2 | Yes | UINT32 | 0.01 | Value for active mode 1. Units as configured on Pump Control Module. |
| x | | 514 | 515 | Mode 1 - Minimum Flow | 2 | Yes | UINT32 | 0.01 | Value for active mode 1. Units as configured on Pump Control Module. |
| x | | 516 | 517 | Mode 2 - Zero Flow Head | 2 | Yes | UINT32 | 0.01 | Value for active mode 2. Units as configured on Pump Control Module. |
| x | | 518 | 519 | Mode 2 - Design Head | 2 | Yes | UINT32 | 0.01 | Value for active mode 2. Units as configured on Pump Control Module. |
| x | | 520 | 521 | Mode 2 - Design Flow | 2 | Yes | UINT32 | 0.01 | Value for active mode 2. Units as configured on Pump Control Module. |
| x | | 522 | 523 | Mode 2 - Minimum Flow | 2 | Yes | UINT32 | 0.01 | Value for active mode 2. Units as configured on Pump Control Module. |
| x | x | 539 | 540 | Control Setpoint | 2 | Yes | UINT32 | 0.01 | Value and unit as configured on pump control mode (constant pressure or constant flow) |

| FUNCTION CODE | | START ADDRESS | MODBUS REGISTER | DESCRIPTION | # OF REGISTERS | CHANGE DURING OPERATION | DATA TYPE | UNIT | NOTES |
|--------------------|-------|---------------|-----------------|------------------------|----------------|-------------------------|-----------|-------|---|
| READ | WRITE | | | | | | | | |
| 0x03 | 0x06 | | | | | | | | |
| Information | | | | | | | | | |
| x | | 900 | 901 | Pump Name / Tag name | 8 | N/A | ASCII | - | The pump name as a series of ASCII characters. |
| x | | 908 | 909 | Serial Number | 7 | N/A | ASCII | - | Serial No. of the Pump represented by ASCII characters |
| x | | 915 | 916 | Firmware Version | 1 | N/A | UINT16 | 00.00 | Divide the number by 100 to get the major, minor version of the DEPC. |
| x | | 916 | 917 | Hardware Version | 1 | N/A | UINT16 | - | The Pump Control Module hardware version. |
| x | | 917 | 918 | BMS Modbus Version | 1 | N/A | UINT16 | - | Version of the Armstrong Modbus registers used. |
| x | | 918 | 919 | Firmware Patch Version | 1 | N/A | UINT16 | 00 | Patch version of the DEPC. To be appended to firmware version register. |

3.4 BACNET OBJECTS - VERSION 2 - FOR FIRMWARE V1.17 AND NEWER

| OBJECT ID | OBJECT NAME | READ/WRITE | COMMENTS |
|-----------------|----------------------------------|------------|--|
| Status | | | |
| AV:100 | Actual Speed | Read | In RPM |
| AV:101 | Actual speed | Read | In % |
| AV:102 | Motor Power | Read | Unit as configured in Pump Control Module |
| AV:103 | Motor Input Voltage | Read | In Volts |
| AV:104 | Motor Input Current | Read | In Amps |
| AV:105 | Sensorless Head | Read | Unit as configured in Pump Control Module |
| AV:106 | Sensorless Flow | Read | Unit as configured in Pump Control Module |
| AV:107 | Total Flow | Read | Used for Parallel sensorless mode |
| AV:108 | Total Power | Read | Used for Parallel sensorless mode |
| AV:109 | No. Of Running Pumps | Read | Used for Parallel sensorless mode |
| AV:110 | Max Sensorless Flow | Read | Unit as configured in Pump Control Module |
| AV:111 | Max Sensorless Head | Read | Unit as configured in Pump Control Module |
| BV:2 | Run Status | Read | 1 → pump is running |
| Counters | | | |
| AV:275 | Total Pump Running Hours | Read | |
| AV:276 | Trip Pump Running Hours | Read/Write | Writing 0 to this register resets the counter. |
| AV:277 | Total Controller Running Hours | Read | |
| AV:278 | Present Controller Running Hours | Read | The running hours since the controller was powered on. |
| AV:279 | Total Pump Running kWh Counter | Read | |
| AV:280 | Trip Pump Running kWh Counter | Read/Write | Writing 0 to this register resets the counter. |

| OBJECT ID | OBJECT NAME | READ/WRITE | COMMENTS |
|----------------------------|--------------------------------|------------|--|
| Control Settings | | | |
| AV:300 | Control Mode | Read | 1 = Parallel; 2 = Inputs; 3 = Remote; 4 = Constant Flow; 5 = Constant Pressure; 6 = Linear Pressure; 7 = Quadratic Pressure; 8 = Quadratic Pressure with Maximum Flow; 9 = Quadratic Pressure with Minimum Flow; 10 = Quadratic Pressure with Minimum and Maximum Flow |
| AV:301 | HOA State | Read/Write | 0 = OFF; 1 = Hand Mode; 2 = Auto |
| AV:302 | Active Parameters | Read/Write | 1 = standard; 2 = mode 1 (heating mode); 3 = mode 2 (cooling mode) |
| AV:303 | Minimum Speed Limit | Read | in RPM |
| AV:304 | Maximum Speed Limit | Read | in RPM |
| AV:305 | Hand Mode Speed | Read/Write | Unit as configured in Pump Control Module. |
| AV:306 | BMS Set Speed | Read/Write | Unit as configured in Pump Control Module. |
| BV:14 | Start/Stop | Read/Write | Start/stop of pump |
| Alarms and Warnings | | | |
| AV:400 | Alarms | Read | Refer to Alarms Table for Bit Positions |
| AV:401 | Warnings | Read | Refer to Warnings Table for Bit Positions |
| AV:402 | Acknowledge Warnings | Read/Write | 32-bit field corresponding to the warning field |
| Parameters | | | |
| AV:500 | Standard Mode - Zero Flow Head | Read/Write | Value for standard active mode. Unit as configured in Pump Control Module |
| AV:501 | Standard Mode - Design Head | Read/Write | Value for standard active mode. Unit as configured in Pump Control Module |
| AV:502 | Standard Mode - Design Flow | Read/Write | Value for standard active mode. Unit as configured in Pump Control Module |
| AV:503 | Standard Mode - Minimum Flow | Read/Write | Value for standard active mode. Unit as configured in Pump Control Module |
| AV:504 | Mode 1 - Zero Flow Head | Read/Write | Value for active mode 1. Unit as configured in Pump Control Module |
| AV:505 | Mode 1 - Design Head | Read/Write | Value for active mode 1. Unit as configured in Pump Control Module |
| AV:506 | Mode 1 - Design Flow | Read/Write | Value for active mode 1. Unit as configured in Pump Control Module |
| AV:507 | Mode 1 - Minimum Flow | Read/Write | Value for active mode 1. Unit as configured in Pump Control Module |
| AV:508 | Mode 2 - Zero Flow Head | Read/Write | Value for active mode 2. Unit as configured in Pump Control Module |
| AV:509 | Mode 2 - Design Head | Read/Write | Value for active mode 2. Unit as configured in Pump Control Module |
| AV:510 | Mode 2 - Design Flow | Read/Write | Value for active mode 2. Unit as configured in Pump Control Module |
| AV:511 | Mode 2 - Minimum Flow | Read/Write | Value for active mode 2. Unit as configured in Pump Control Module |
| AV:520 | Control Setpoint | Read/Write | Value and unit as configured on pump control mode (constant pressure or constant flow) |
| INFORMATION | | | |
| AV:900 | BMS BACnet Version | Read | Version of the Armstrong BACnet points used. |
| I/O | | | |
| AI:0 | Analog In 1 | Read | As configured in Pump Control Module |
| AI:1 | Analog In 2 | Read | As configured in Pump Control Module |
| AV:113 | Analog Out 1 | Read | As configured in Pump Control Module |
| BI:0 | Digital In 1 | Read | As configured in Pump Control Module |
| BI:1 | Digital In 2 | Read | As configured in Pump Control Module |
| BV:15 | Digital Out 1 | Read | As configured in Pump Control Module |
| BV:16 | Digital Out 2 | Read | As configured in Pump Control Module |
| BV:0 | Relay 1 | Read | As configured in Pump Control Module |
| BV:1 | Relay 2 | Read | As configured in Pump Control Module |

4.0 OPERATION

4.1 START-UP CHECKLIST



Particular care must be taken to check the following before the pump is put into operation:

- A Pump primed?
- B Rotation **ok**?
- C Lubrication **ok**?
- D Pipe work properly supported?
- E Voltage supply **ok**?
- F Overload protection **ok**?
- G Is the system clean?
- H Is the area around the pump clean?

NOTE: FOR DEPM2 MOTORS:

Ensure that the STO jumpers are in place

Warranty

Does not cover any damages to the equipment resulting from failure to observe the above precautions. Refer to Armstrong General Terms and Warranty sheet. Contact your local Armstrong representative for full information.

4.2 STARTING PUMP



Ensure that the pump turns freely by hand, or with some gentle mechanical help such as a strap or Allen key in coupling bolt.

Ensure that all protective guarding is securely fixed in position.

The pump must be fully primed on start up. Fill the pump casing with liquid and rotate the shaft by hand to remove any air trapped in the impeller. On split-coupled Design Envelope units any air trapped in the casing as the system is filled must be removed by the manual air vent in the seal flush line. **Ensure entrained air is removed from Design Envelope pumps, prior to starting, through the air vent on the seal flush line. Open vent until clear of air.**

Design Envelope close-coupled units are fitted with seal flush/vent lines piped to the pump suction area. When these units operate, residual air is drawn out of the pump towards the suction piping. energize the motor momentarily and check that the rotation corresponds with the directional arrow on the pump casing (clockwise when viewed from non-drive end of motor).

Start the pump with the discharge valve closed and the suction valve open, then gradually open the discharge valve when the motor is at operating speed. The discharge valve may be **cracked** or open slightly at start up to help eliminate trapped air.

When stopping the pump: Close the discharge valve and de-energize the motor.

Do not run the pump against a closed discharge valve at full speed for an extended period of time (a few minutes maximum.)

Should the pump be noisy or vibrate on start-up a common reason is overstated system head. Check this by calculating the pump operating head by deducting the suction pressure gauge value from the discharge gauge reading. Convert the result into the units of the pump head as stated on the pump nameplate and compare the values. The system designer or operator should be made aware of this soon as some adjustment may be required to the drive settings to make the pump suitable for the system as installed.



Check rotation arrow prior to operating the unit. The rotation of all Armstrong 4200H & 4280 Vertical in-line units is clockwise when viewed from behind the motor (NDE).

4.2.1 AUTO FLOW BALANCING

Auto-Flow Balancing automatically determines the control curve between the design flow at the on-site system head, and the minimum (zero-flow) head that will typically be lowered (reset).

Often the actual system head is less than expected, and the pump will operate further to the right of the curve at a higher flow rate than it was designed for due to less system resistance. The Auto Flow Balancing function performs a scan of the sensorless map against the actual system to establish the actual head for the design flow. The minimum (zero-flow) head will be reset according to the actual head at the design flow - the factory default is 40% of the design head, but can be lowered further for more energy savings if all zones are still satisfied.

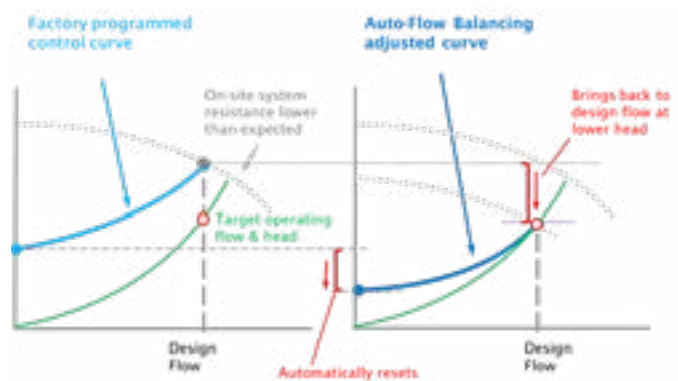

For buildings that are commissioned in multiple stages, or where the design flow changes each time, the Auto Flow Balancing function can be run at the beginning of each stage.

From the touch screen, go to **Pump Configuration -> Auto Flow Balancing**, then follow the on-screen instructions. The Auto Flow Balancing scan takes approximately 3 minutes to complete.

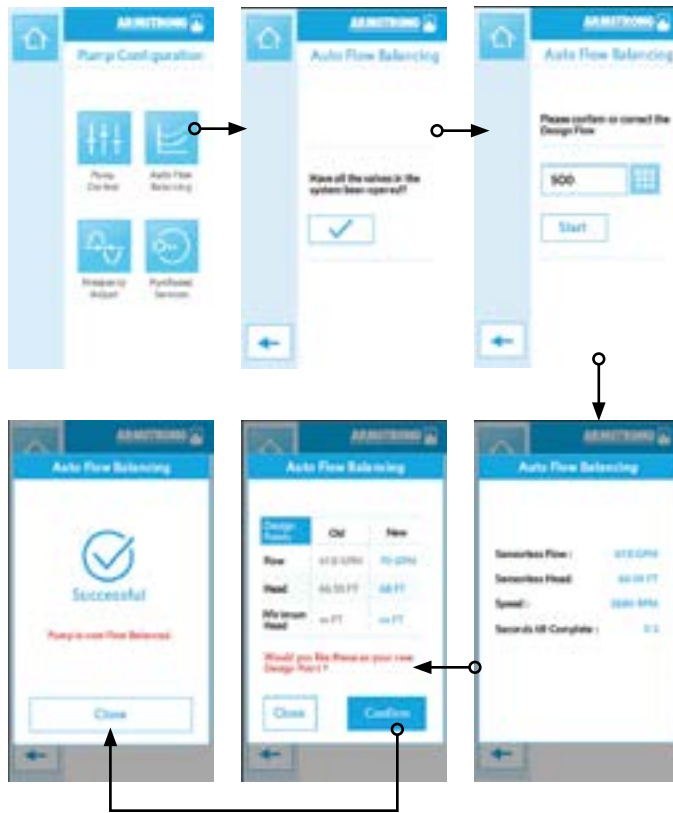

4.3 TOUCH SCREEN

4.3.1 LOGIN

Default Password 1234



4.3.2 LOGOUT



4.3.3 ABOUT

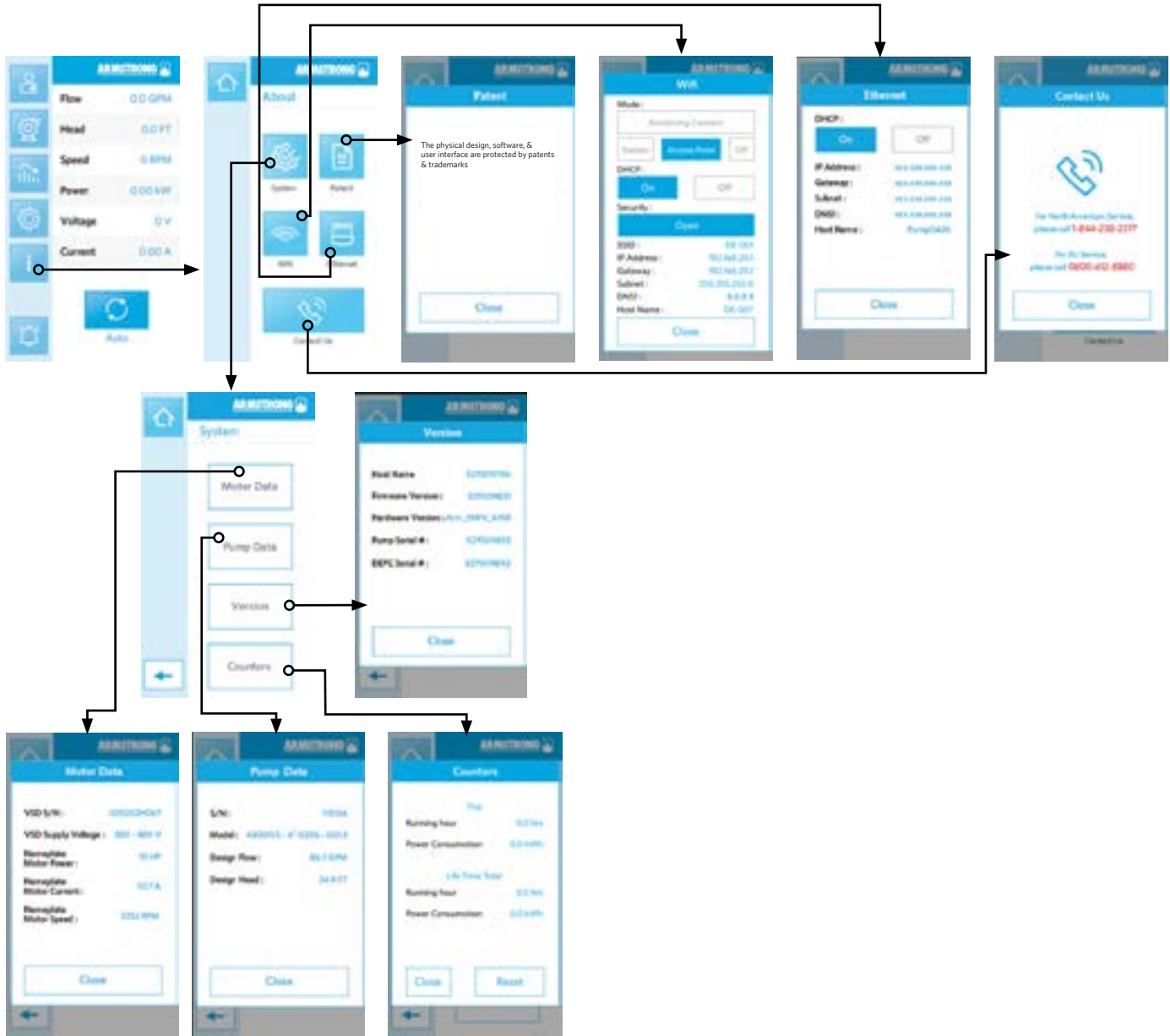

Click on **Reset** to reset Trip counters

4.3.4 GENERAL SETTINGS

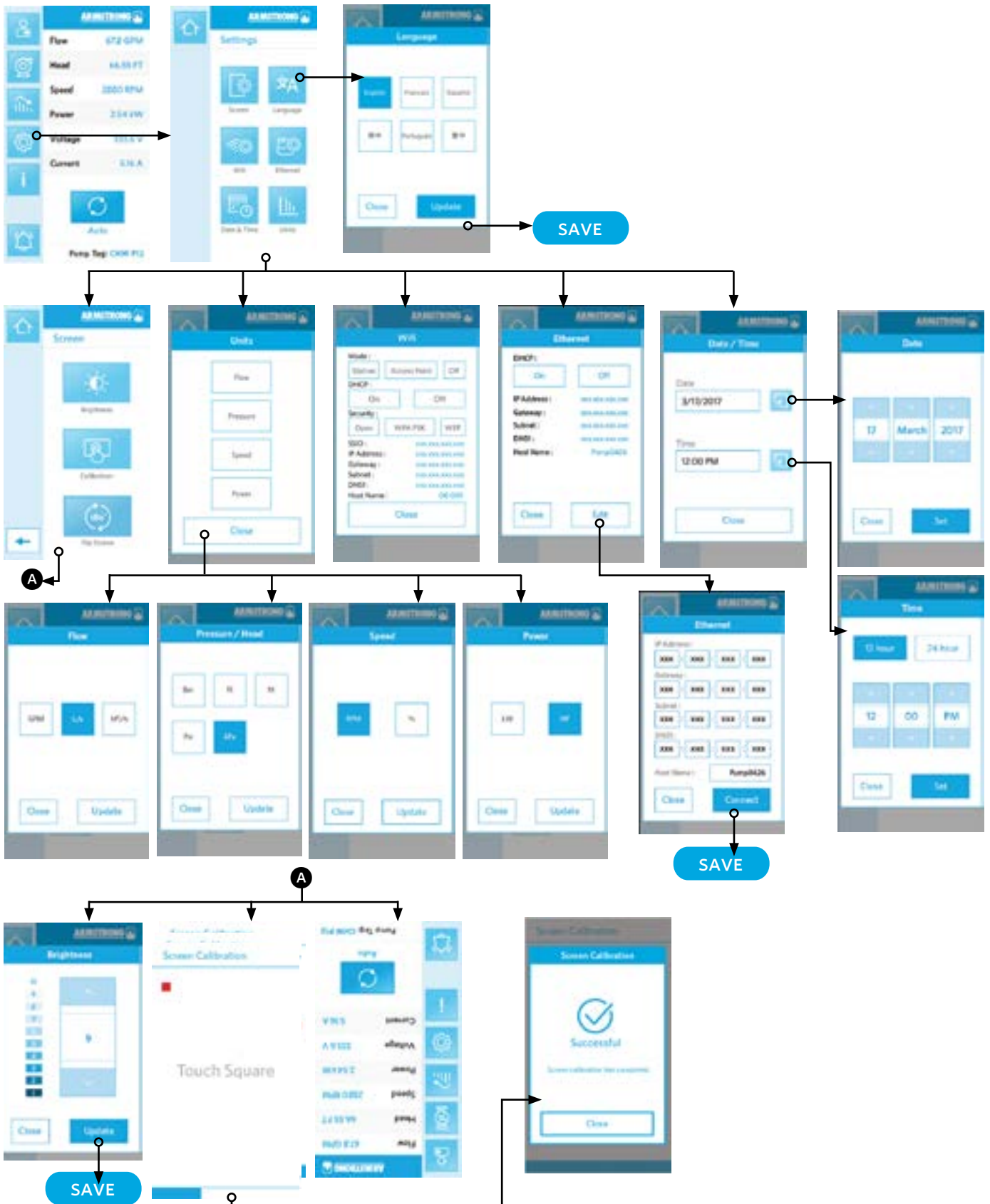

4.3.5 MANUAL/AUTO MODE

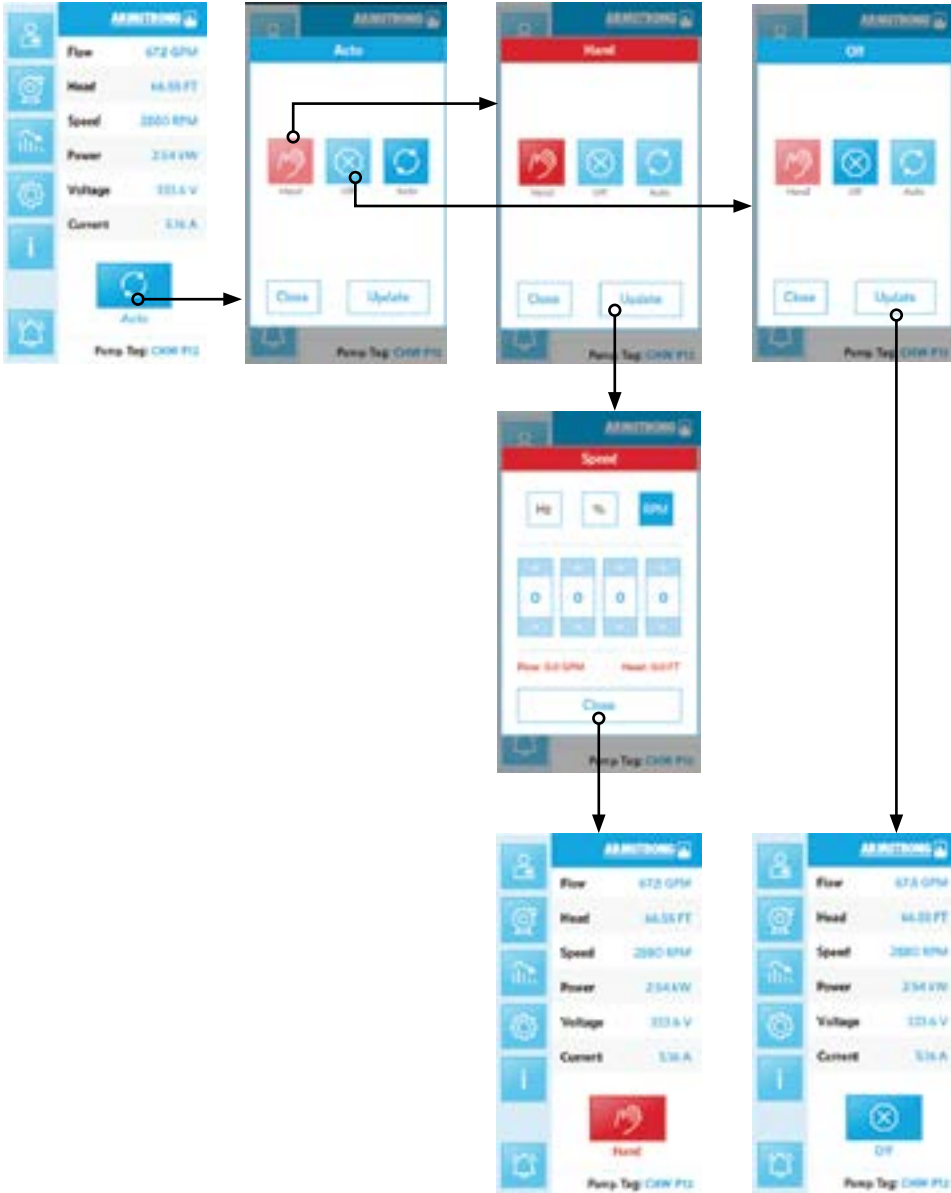

4.3.6 PUMP CONTROL

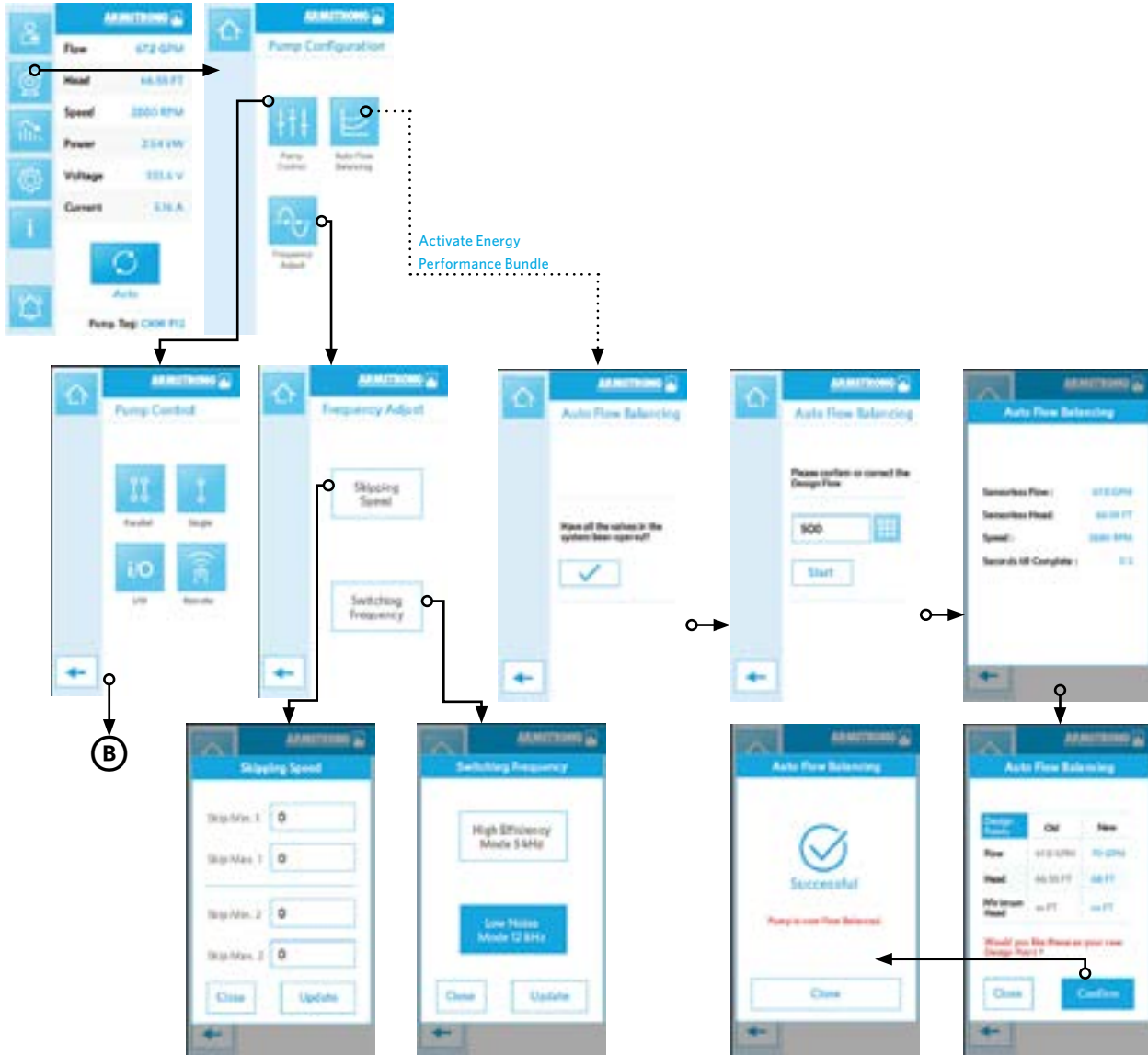

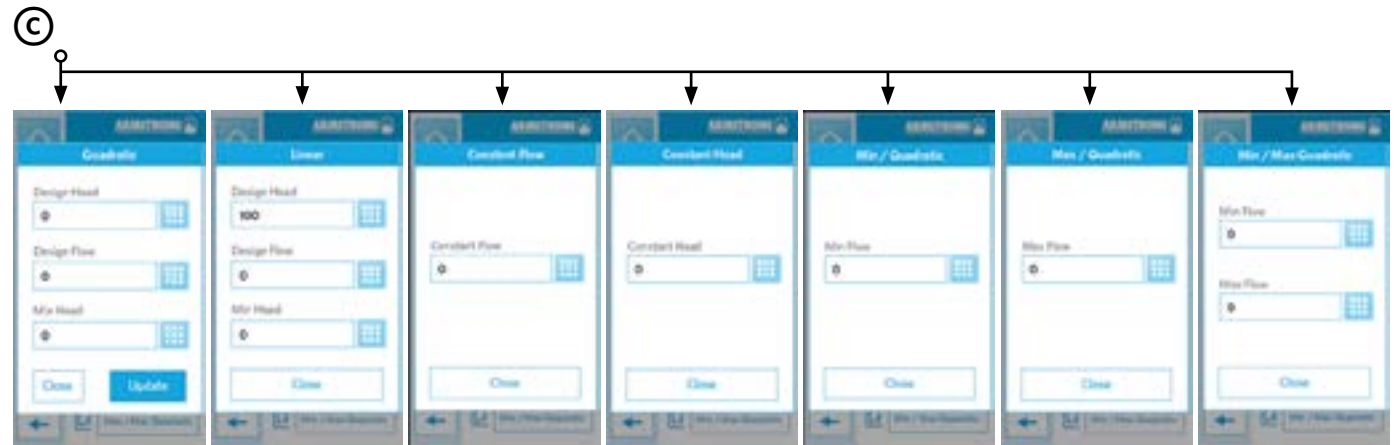
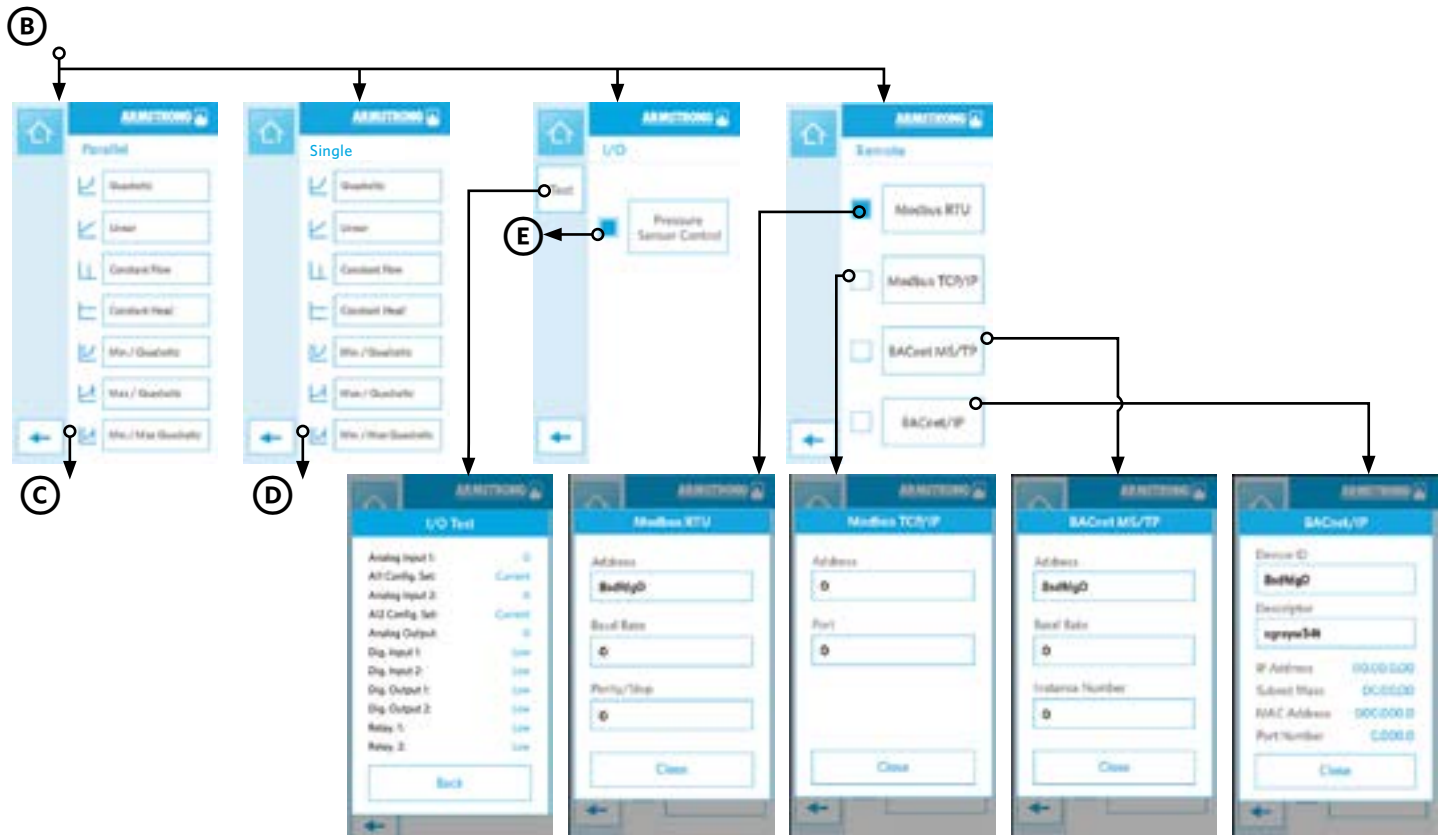

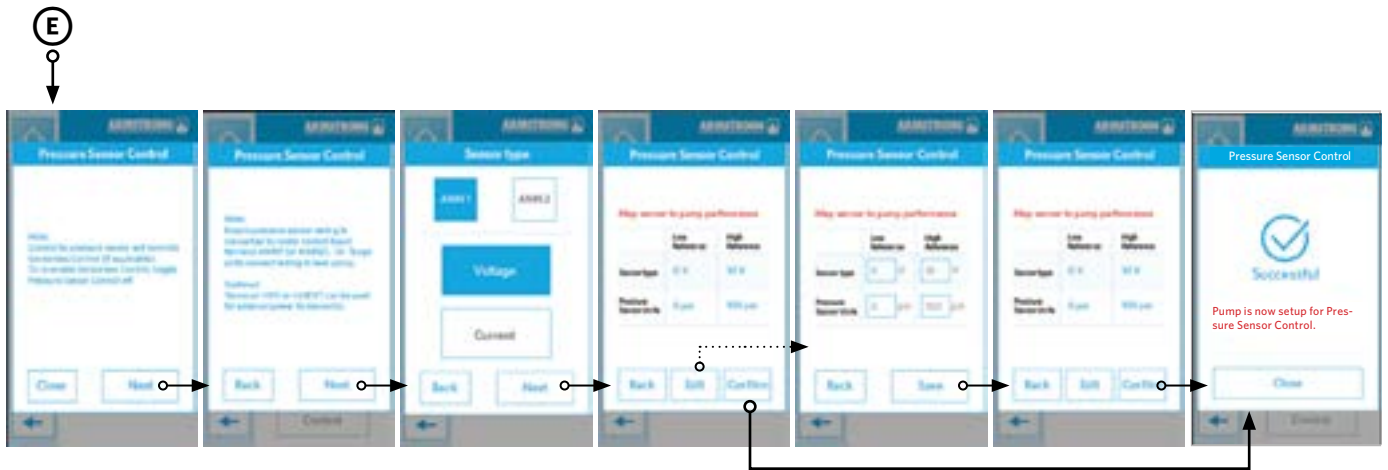

4.3.7 ALARMS & WARNINGS

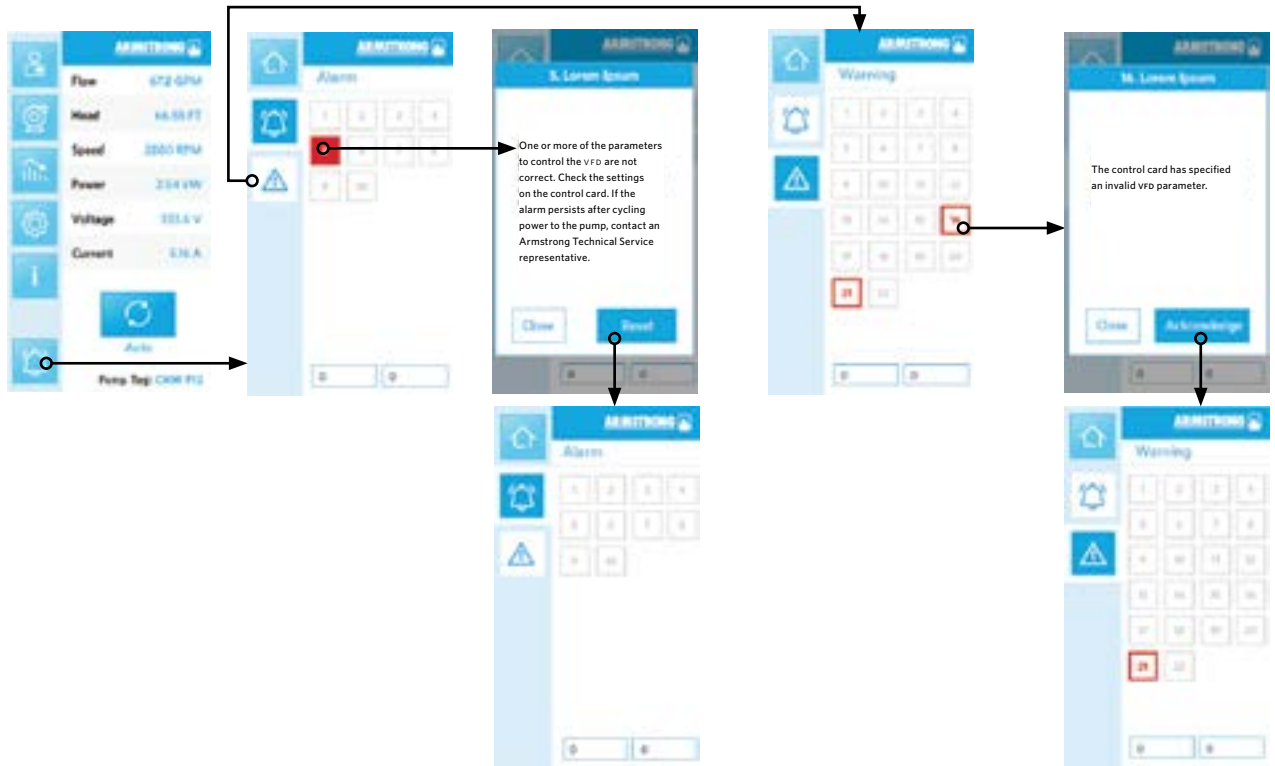

4.3.8 TREND-GRAPH

There are 3 parameters that can be trended on the touch screen interface:

- Power
- Flow
- Head

Which allows users to see a quick history of key performance data.

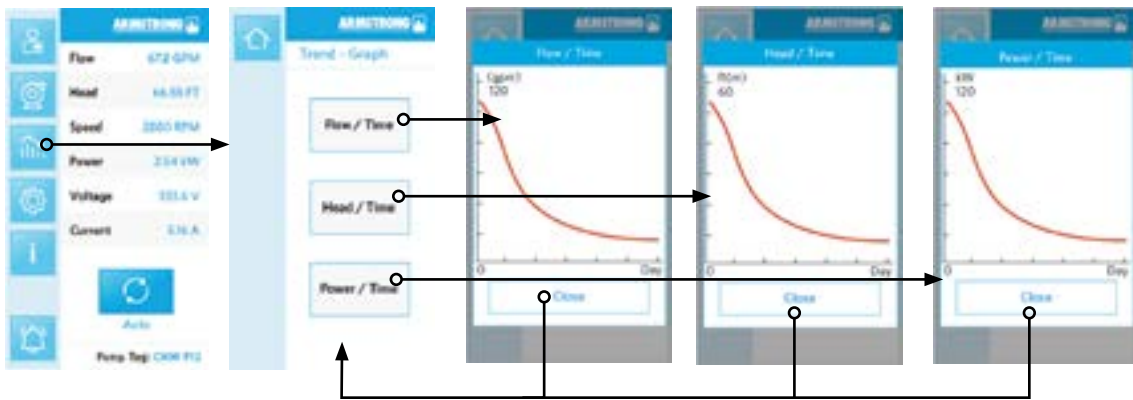

To see a more comprehensive view of the trends, the pump data can be exported in CSV format for review and analysis on a separate computing device.

4.3.9 BRIGHTNESS ADJUSTMENT

To adjust the brightness of the touch screen interface, go to **Settings -> Brightness**.

10 = highest brightness, 1 = lowest brightness



4.3.10 TOUCH SCREEN CALIBRATION

If you are having issues with the touch screen, including:

- Being unable to access items to the edge of the screen
- Some buttons from the display are unresponsive

The touch screen may require re-calibration. To calibrate the touch screen, go to **Settings -> Screen -> Calibration**

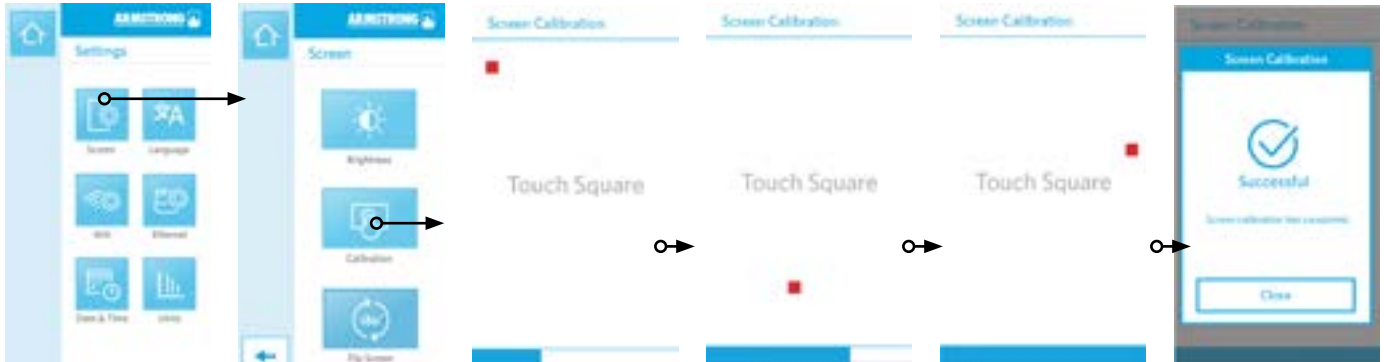

Follow the following 3-step calibration sequence (touching the squares) to reset the display coordinates.

If you are unable to access the Calibration function from the touch screen itself, connect the pump to the webserver and go to **Settings -> General -> Recalibrate LCD Screen**. This will trigger the calibration sequence on the touch screen of the pump. Follow the above 3-step calibration sequence to reset the display coordinates.

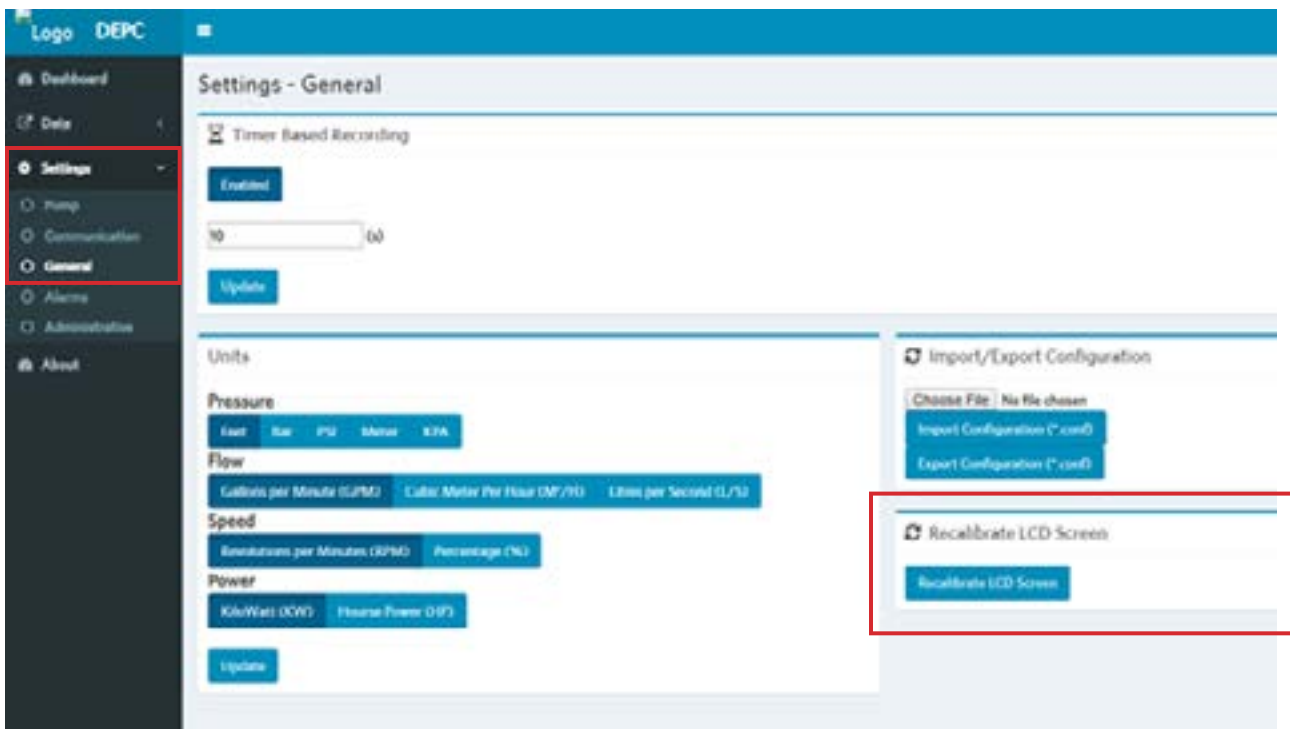

4.3.11 DATA LOGGING

Data logs can be used for energy performance analyses or to troubleshoot system issues. The data logs can be used with a building automation system (BAS) or for each standalone pump. Each pump controller logs the following data parameters over pre-defined time intervals (default is 5 minutes).

- Speed (rpm)
- Power (kW)
- Current (A)
- Flow (gpm)
- Head (ft)
- Analog Input 1
- Analog Input 2
- Analog Output
- Digital Input
- Digital Output
- Alarms
- Warnings
- kW-hours

The DEPC stores up to 3 months of data, at 5 min. intervals. More data storage is available on the cloud server if the pump is connected to the internet and has an active Pump Manager subscription.



Connect the DEPC to the Webserver, in the **Data -> Trends -> Export Log File** section.

Select the start date, the end date, and then click **Export History** to download the data log file in CSV format.

4.4 WEB INTERFACE

Armstrong Strongly recommends to use Google Chrome browser to access DEPC web interface. Other browsers might be used but Google Chrome will guarantee the best operation.

4.4.1 CONNECTING VIA ETHERNET

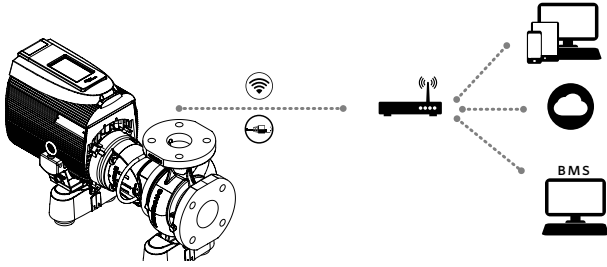

Connect your device to the router via wifi or by Ethernet cable.

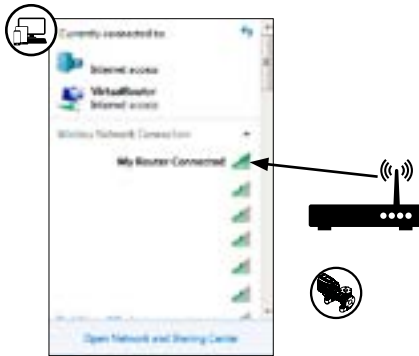

4.4.2 CONNECTING VIA WIFI

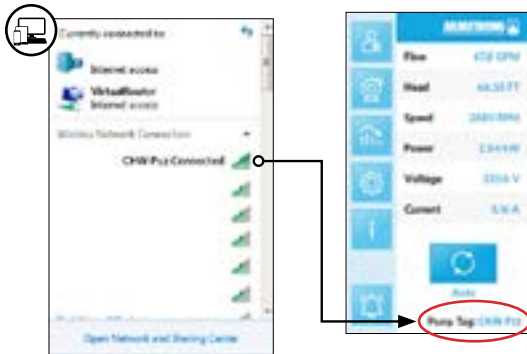

At the web browser address bar, type the Pump's IP (from Pump's About screen, Ethernet IP address).

Default user level 1 Password: Armstrong1



To access the control modes:

Press settings → Pump



Press settings → General, select desired units and click Update



To set the interval for timer based recording: Press settings → General, click on enable and input the desired time (default is 300 seconds)

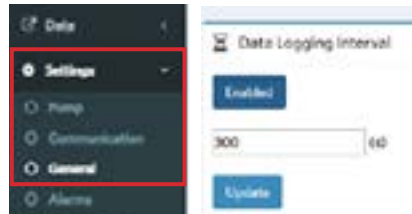

To Import/Export configuration files: Press Settings → General, select a file and click on **Import Configuration** to input. Click on Export Configuration to export

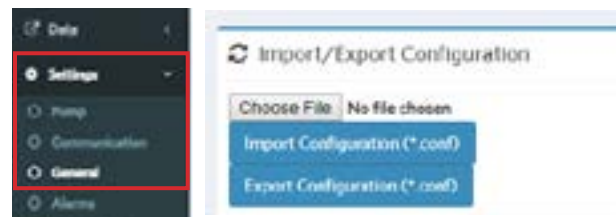

To modify Date/Time: click Settings → General and modify date and time



To modify out settings: Settings → Pump,

To modify digital outputs: enable in Outputs and select desire,

To modify analog outputs: click enable and speed.

To modify relay settings: enable Relay functions and select desired settings



To access the control modes: Press settings → Pump

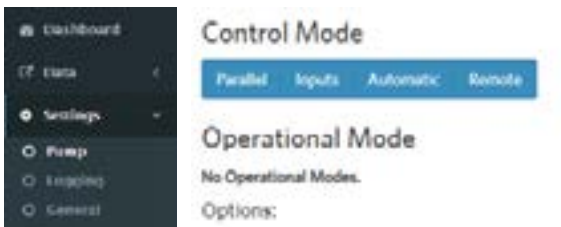

To enable Armstrong Connect: Settings → Communication, and click on Armstrong Connect to enable

To select Version 1 or 2 of BMS settings, Click on Remote mode and select Version 1 or 2.

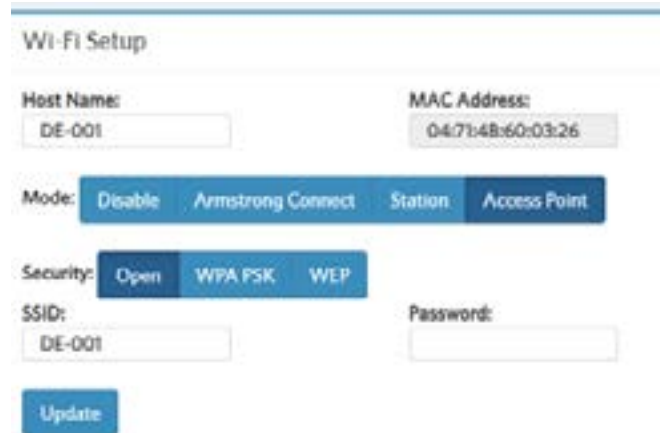
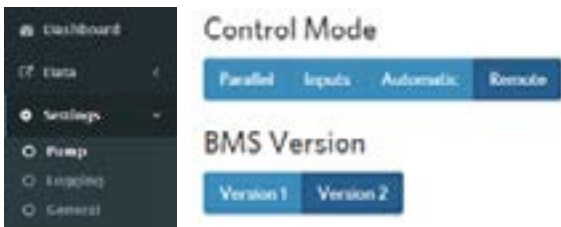

Settings → Pump,

To change motor ramp up and down settings, input in **Motor Ramp up Time** and **Motor Ramp Down Time**

To change Pump high and Low Speed, input RPM in **High Speed Limit** and **Low Speed Limit**

To change pump tag, input new tag in **Pump Tag**

To set the BACnet max info from, Settings → Communication, enable BACnet Serial and input in **Max Info. Frame**



4.5 DESIGN ENVELOPE FLOW READOUT TOLERANCE

Tolerance on flow and head readings between test stand instrumentation and Design Envelope controller readout will be within 5% of BEP flow & head values for all Design Envelope sensorless pump selections.

The same BEP flow & head tolerance values will be carried to the Design Envelope selection point for that model (Guarantee point, to ANSI 40.6 Hydraulic Institute Standard-See FIG. 4.1), as follows:

FIG. 4.1

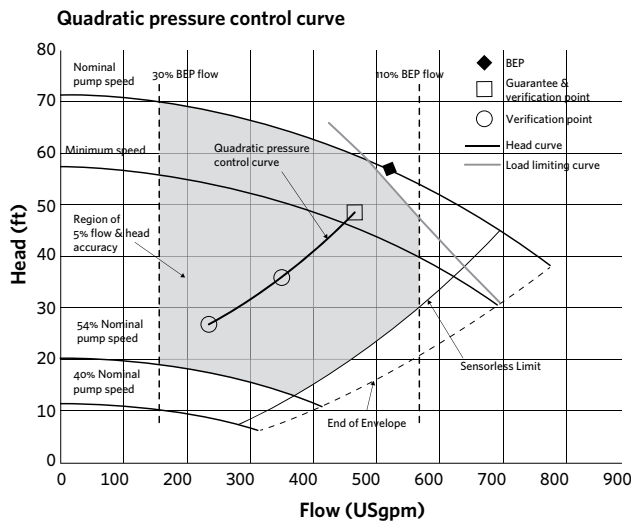

The tolerance is applicable when the flow is between 30% and 110% of BEP flow at Nominal Pump Speed; and the operating point is at 54% of Nominal Pump Speed, or greater.

Nominal Pump Speed is displayed as the top speed on any Design Envelope pump curve.

4.6 NOISE LEVELS

Motor Maximum Sound Pressure Level

| PUMP MODEL | HP | [dBA] |
|-------------|-----|-------|
| 1203-001.0 | 1 | 68 |
| 1203-001.5 | 1.5 | 68 |
| 1505-001.5 | 1.5 | 64 |
| 1505H-001.5 | 1.5 | 64 |
| 1505-002.0 | 2 | 64 |
| 1505H-002.0 | 2 | 64 |
| 1505-003.0 | 3 | 62.6 |
| 1505H-003.0 | 3 | 62.6 |
| 1505-005.0 | 5 | 69.2 |
| 1505-007.5 | 7.5 | 69.2 |
| 1505-010.0 | 10 | 80.3 |
| 0205-001.5 | 1.5 | 64 |
| 0205-002.0 | 2 | 64 |
| 0205-003.0 | 3 | 62.6 |
| 0205-005.0 | 5 | 69.2 |
| 0205-007.5 | 7.5 | 69.2 |
| 2505-003.0 | 3 | 62.6 |
| 2505-005.0 | 5 | 62.6 |
| 2505-007.5 | 7.5 | 69.2 |
| 2505-010.0 | 7.5 | 77.0 |

Sound pressure level measurements made in accordance with ISO 3744, ± 3dB tolerance (measuring level A-Weighted)

Data based on motor frames at 380-480V. Audible noise is mainly from the motor fan and will be reduced when operating at part load.

5.0 CONTROL MODES

5.1 CONSTANT FLOW

Design Envelope pumps can be configured to maintain a constant pump flow in a system as the system head varies. This effectively simulates speed control by a flow meter in the piping.

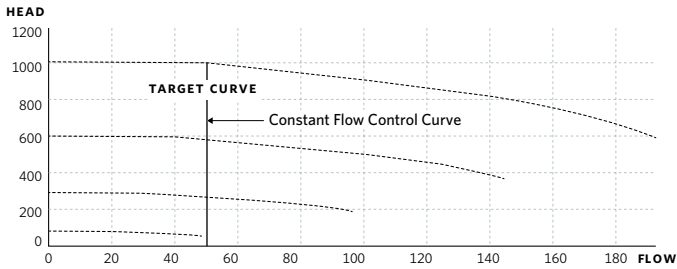

5.2 CONSTANT PRESSURE

Design Envelope pumps can be configured to maintain a constant pump head in a system as the demand varies. This effectively simulates the mounting of a differential pressure sensor at, or near, the pump.

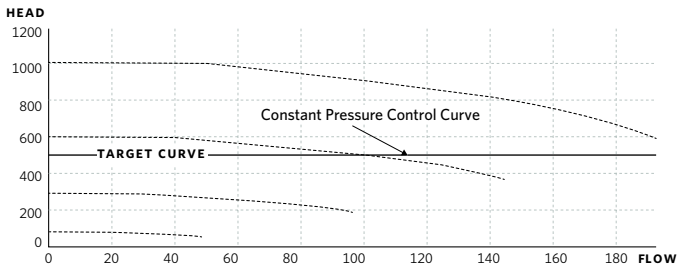

5.3 LINEAR PRESSURE

Linear Pressure Control is where the controller is set to control the speed according to a control 'curve' between max and min flow. This type of control will change the pump speed to ensure the pump operates on the projected linear control curve, where the pump head varies directly with the flow. This type of control is well known globally and is effective as far as the straight linear line will allow. For more realistic HVAC control with superior energy savings, consider the following control recommendation 5.4 Quadratic Curve Control.

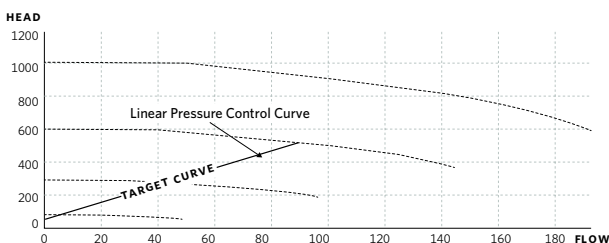

5.4 QUADRATIC CURVE CONTROL

Quadratic Pressure Control is where the controller is set to control the speed according to a control curve between max and min flow. It is widely recognized that fitting a differential pressure sensor at the most remote load, across the supply piping and return piping encompassing the valve and coil set, is the benchmark scheme for energy efficiency.

Design Envelope pumps can replicate this control without the need for the remote sensor. As the flow required by the system is reduced, the pump automatically reduces the head developed according to the pre-set control curve.

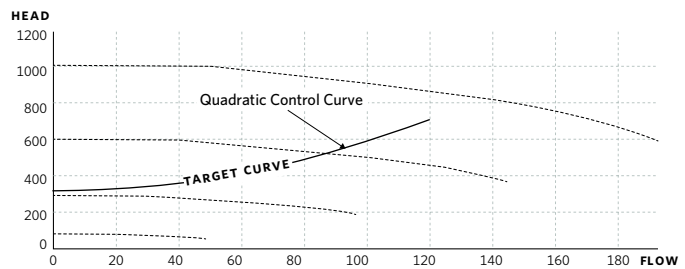

5.5 QUADRATIC CURVE CONTROL WITH MINIMUM FLOW PROTECTION

This configuration is designed for HVAC hydronic systems where flow sensitive equipment required a minimum flow for equipment stability; such as a chiller that cannot tolerate flow below a certain volume. This control will take advantage of the 5.4 Quadratic Curve Control mode, where the pump will increase speed to maintain a minimum flow setting as the system load is shutting down.

Pump controls can only control the flow to the maximum speed or motor limit;

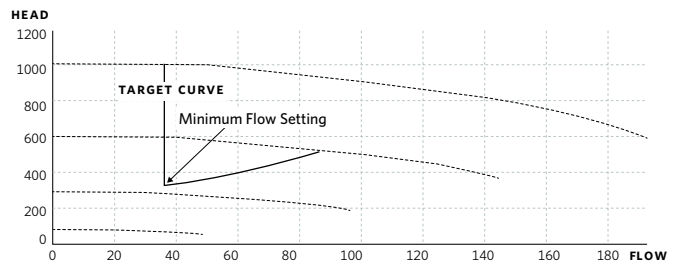

5.6 QUADRATIC CURVE CONTROL WITH MAXIMUM FLOW PROTECTION

This configuration is ideal for HVAC hydronic systems where pumps are generally oversized and a flow limit is required for system equipment stability and resulting energy savings. This control will take advantage of the 5.4 Quadratic Curve Control mode, where the pump will decrease speed to maintain

a maximum flow setting. This will prevent over-pumping and save energy costs. Over-pumping is common in HVAC systems as pumps are typically oversized for the application. Pump controls can only control the flow to a minimum speed; thus a dry-contact relay is supplied which will close when maximum flow is reached, which can be used for an alarm or other device.

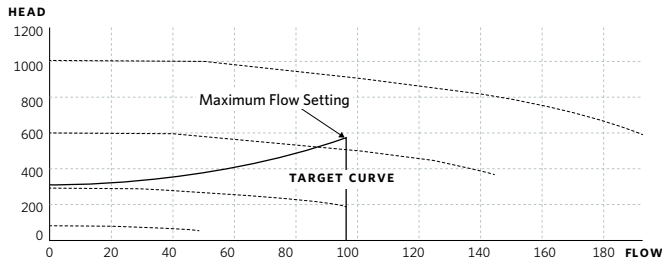

5.7 QUADRATIC CURVE CONTROL WITH MINIMUM & MAXIMUM FLOW PROTECTION

This control mode combines the control logic of 5.5 & 5.6 which takes the values of the quadratic control curve and protection for both the maximum & minimum flow limits. Pump controls can only control the flow to the motor limit or maximum / minimum speed limits of the unit, thus a dry-contact relay is supplied which will close when either the minimum or maximum flow is reached, which can be used for an alarm or other device.

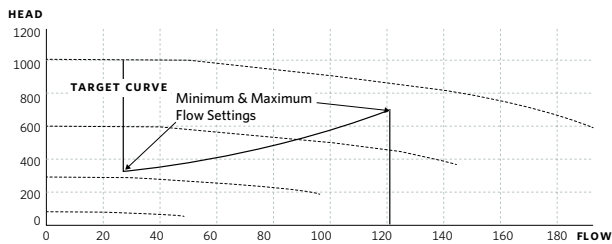

5.8 PARALLEL SENSORLESS PUMP CONTROL (PSPC)

This configuration maps the quadratic control curve into the pump controls and ensures the system flow requirements are met, while staging the pumps on and off to maintain optimum pump energy usage. This is accomplished by operating the pumping units at the best pumping efficiency level for the required flow.

This control is available for 2, 3, or 4 Design Envelope pump units operating in parallel. Tango and dualArm units have Parallel Sensorless Pump Control (PSPC) pre-programmed in the controls at Armstrong factories. For all other models (except twin pumps), PSPC can be enabled aftermarket; please contact your local Armstrong factory for details.

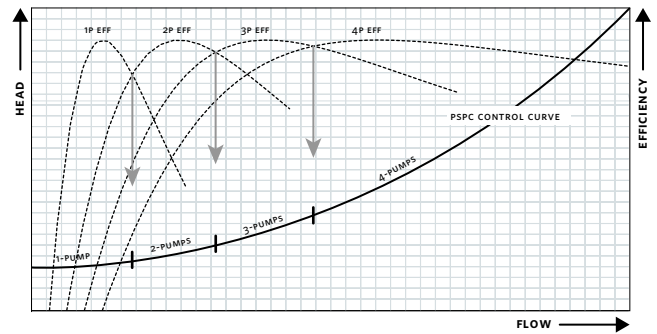

Both individual pumps and total parallel flow can be monitored by accessing **Settings -> Pump -> Control Mode -> Parallel Sensorless**



5.8.1 EMBEDDED PARALLEL SENSORLESS PUMP CONTROL FOR MULTIPLE PUMPS

If the Parallel Sensorless Pump Control option was purchased for control of 2, 3 or 4 single pumps (VILs and End Suctions) the function can be enabled at any time. Note that pumps must be of the same model for parallel operation.

Start by installing a wiring bridge between the pumps (supplied by others). The wiring between the control cards is a CANBUS (3-wire) cable with terminal blocks at each end (3 position strain 3.81 mm).

For connection of 3 or 4 pumps, the CANBUS connectors should be daisy-chained together.

Wiring bridge supplied by others.

For 2 pump parallel operation:

Ensure that both terminating resistor switches are set to Enabled (towards the **EN** label for the CANBUS port).

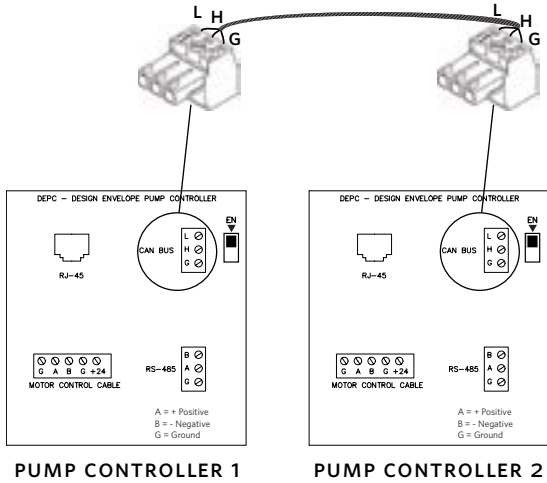

From the Webserver, choose Settings -> Pump, set control mode to Parallel with the following parameter values:

Control Mode



Options:

A Id:

Flow BEP:

Head BEP:

B Dead Band:

C Total Design Flow:

Stage On Speed Percent:

Stage Off Speed Percent:

D Sensorless Map Adjust Factor:

Alternation Interval (minutes):

E Minimum On Time (Seconds):

For 3 or 4 pump parallel operation:

Ensure that only the first and last terminating resistor switches are set to Enabled (towards the **EN** label for the CANBUS port).

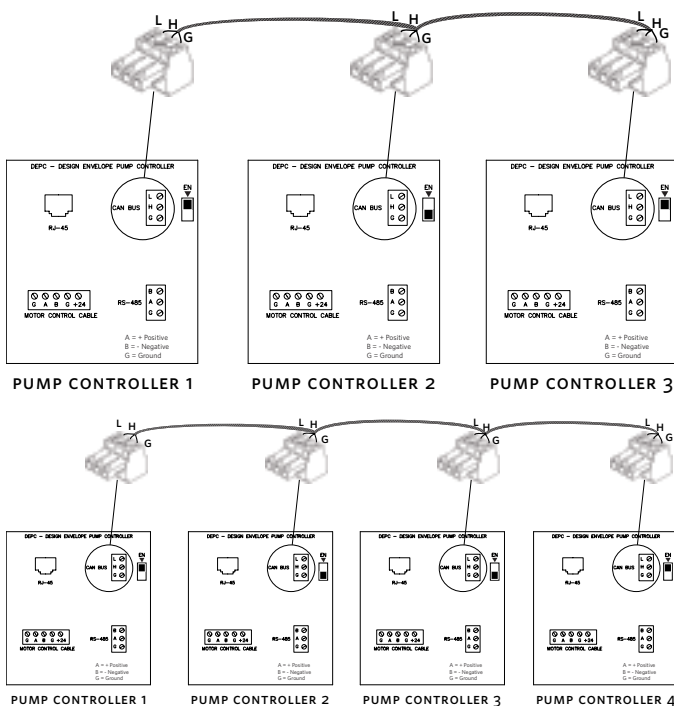

- A** ID: 1 to 8, the lower number is the lead pump e.g. enter **1** for lead pump, **2** for lag pump
- B** Dead Band: set to 0.25
- C** Total Design Flow: enter the parallel flow rate
- D** Sensorless Map Adjust Factor: set to 0.1
- E** Minimum On Time (seconds): set to 15

Click **UPDATE** to save all changes. Connect the Webserver to the second pump and then repeat above steps **A** to **E**.

5.8.2 MODIFYING MOTOR RAMP UP AND DOWN TIME

Modify the time in the respective fields after clicking on **Pump** under **Settings**

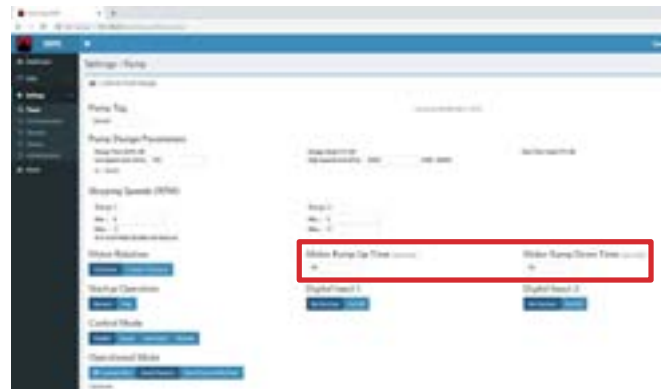

5.8.3 THREE DIFFERENT CONTROL MODES CAN BE ACCESSED

Constant Flow, Quadratic Pressure and Quadratic Pressure with Minimum Flow.



5.8.4 FALLBACK PERCENTAGE OF MAXIMUM SPEED

While operating multiple pumps in Parallel Sensorless mode, if any of the pumps are disconnected from the communication circuit (e.g. the pump is disconnected from the CANbus wire), the disconnected pump will now continue to operate at a pre-set constant speed - or the fallback speed. The fallback speed can be set to a percentage of the pump's maximum speed (between 40-100%).

Note that only the disconnected pump will operate at constant speed, the other remaining pumps in the communication circuit will continue to operate in Parallel Sensorless mode to the control curve.

This can be done in **Operational Mode** and input the **Fallback % of Max Speed**

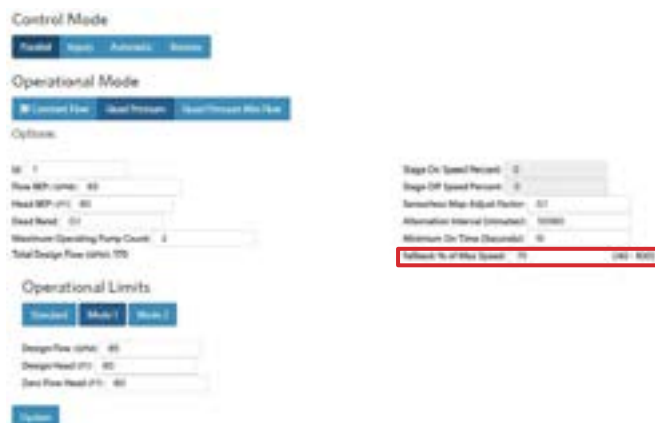

5.8.5 STANDBY PUMPS

Scroll down to **Operational Mode** and input the **Maximum Operating Pump Count**. The remaining pumps will be Standby. Calculated Design Flow will automatically update based on the number of pumps inputted.

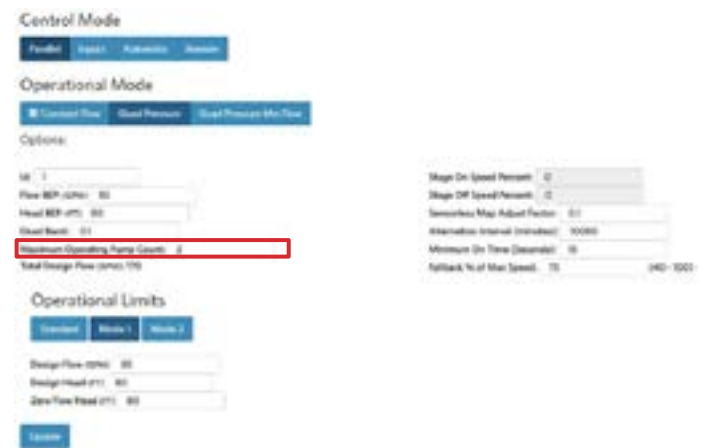

5.9 2*100% CAPACITY SPLIT UNITS

When duty / standby is specified, enter the total system flow into ACE Online or ADEPT, then select 2*100% unit split for a superior customer value. The 100% flow redundancy is still in place **plus** the onboard PSpC will engage the second unit in parallel operation should it predict lower operating costs.

If second side power is locked out, the operating pump will operate alone on the control curve to 100% design flow.

5.10 ALTERNATION

Design Envelope Tango, dualARM, and Twin units are pre-set to alternate lead-pump operation of each pump head to achieve equal run hours. The default alternation interval is 10,080 minutes (1 week). This can also be set or adjusted for multiple single pumps operating in sequence.

To change this setting, use the Webserver and go to Settings -> Pump, and then go the Control Mode section, under the Parallel tab, and input the Alternation Interval (in minutes) to the new value. Press UPDATE to complete the change. Connect the Webserver to the second pump and repeat.

Control Mode



Options:

| | |
|---------------------------------|-------|
| Id: | 1 |
| Flow BEP: | 85 |
| Head BEP: | 80 |
| Dead Band: | 0.25 |
| Total Design Flow: | 171.4 |
| Stage On Speed Percent: | 0 |
| Stage Off Speed Percent: | 0 |
| Sensorless Map Adjust Factor: | 0.1 |
| Alternation Interval (minutes): | 10080 |
| Minimum On Time (Seconds): | 15 |

5.11 CONSTANT PRESSURE CONTROL

Can be achieved if **Design Head** and **Zero Flow Head** are set to same value



5.12 DUAL SEASON SETUP

Design Flow, Head and Zero Flow Head in Mode 1 and Mode 2 can be used as the two seasons of a Dual Season Setup

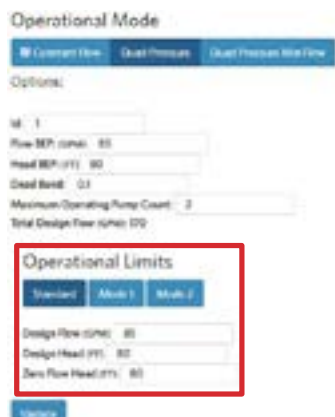

5.13 SENSORED CONTROL

dP sensors can be added to a single pump or a parallel pumping system through either the LCD Screen on the Pump or the Webserver.

5.13.1 ADDING DP SENSORS THROUGH LCD SCREEN

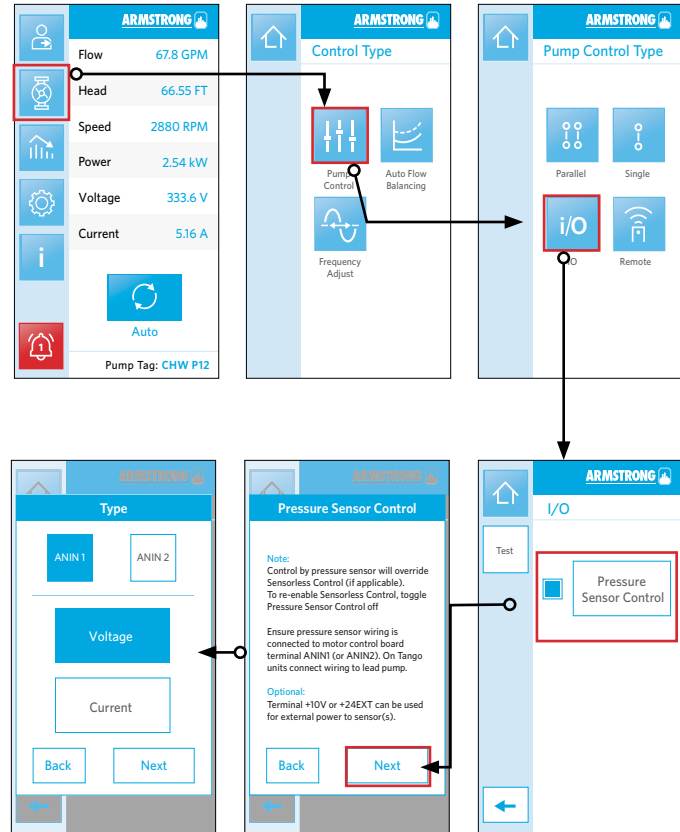

5.13.2 ADDING DP SENSORS FROM WEBSERVER

Scroll down to **Control Mode: Inputs**



5.14 BYPASS VALVE CONTROL

The bypass valve control is used to protect flow sensitive equipment (such as chillers). If the flow is less than Setpoint 1, the DEPC analog output sends 20 mA to fully open the valve. If the flow is greater than Setpoint 2, the DEPC analog output sends 4 mA to fully close the valve. There should be a sufficient gap between Setpoint 1 and 2 Flows to prevent the bypass valve from opening and closing unnecessarily. The recommended bypass valve is a modulating non-spring return valve (normally closed) with either 4-20 mA analog input, or 2-10 Vdc analog input (requires adding 500 ohm resistor across the valve input).

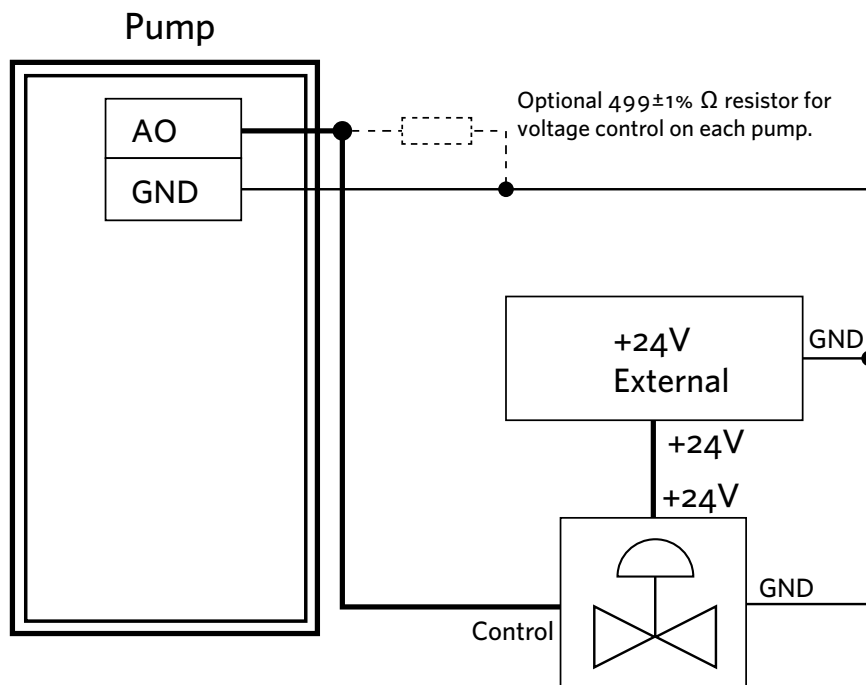
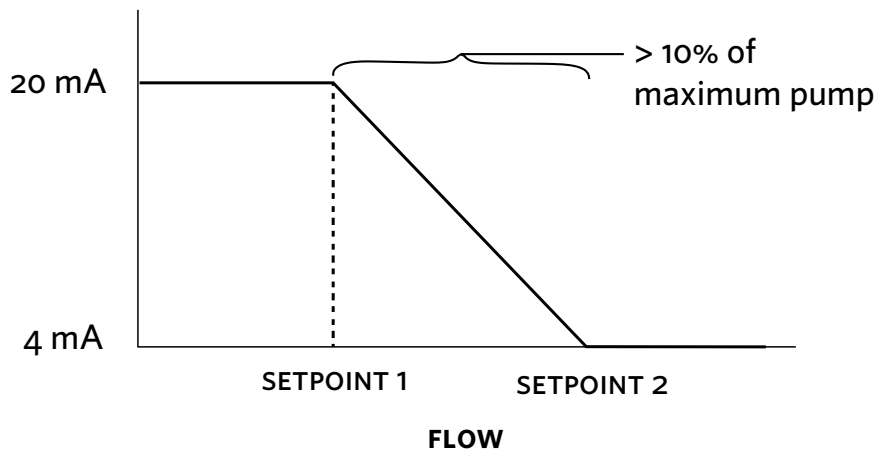

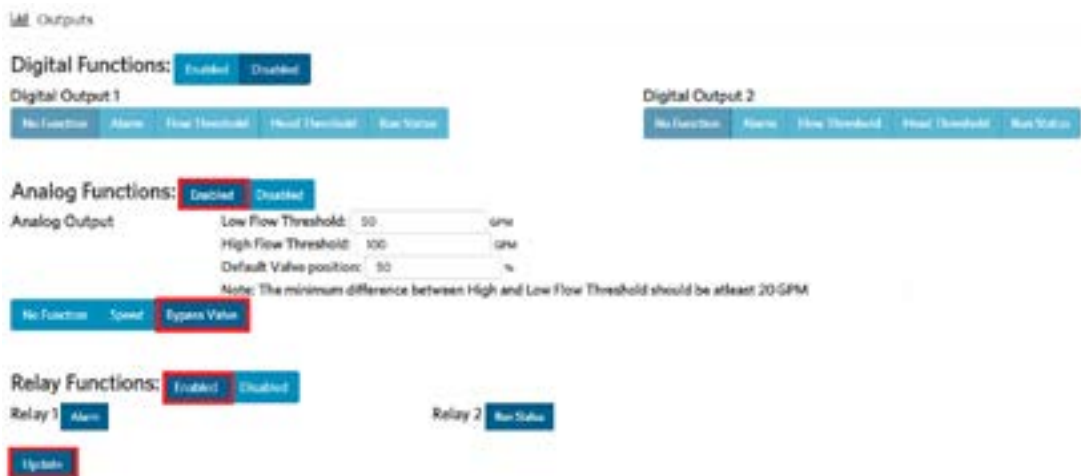
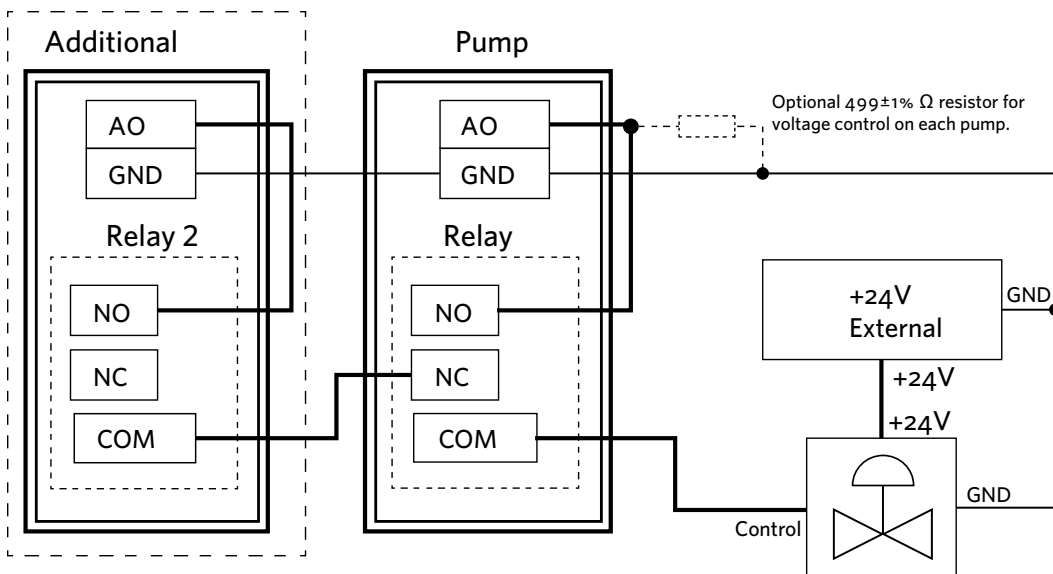

6.0 MAINTENANCE

6.1 GENERAL CARE

Vertical in-Line pumps are built to operate without periodic maintenance, other than motor lubrication on larger units. A systematic inspection made at regular intervals, will ensure years of trouble-free operation, giving special attention to the following:

- Keep unit clean
- Provide the motor with correctly sized overload protection. Keep moisture, refuse, dust or other loose particles away from the pump and ventilating openings of the motor.
- Avoid operating the unit in overheated surroundings (Above 100°F/40°C).

WARNING



Whenever any service work is to be performed on a pumping unit, disconnect the power source to the driver, lock it off and tag with the reason. Any possibility of the unit starting while being serviced must be eliminated. If mechanical seal environmental accessories are installed, ensure water is flowing through the sight flow indicator and that filter cartridges are replaced as recommended. (See Armstrong files 43.85 and 43.86 for seal environmental instructions).

6.2 LUBRICATION

Pump

Lubrication is not required. There are no bearings in the pump that need external lubrication service.

Large Design Envelope 4200H units are installed with a shaft bushing located beneath the impeller that is lubricated from the pump discharge.

Motor

Follow the lubrication procedures recommended by the motor manufacturer. Many small and medium sized motors are permanently lubricated and need no added lubrication. Generally, if there are grease fittings evident the motor needs periodic lubrication. None if not.

Check the lubrication instructions supplied with the motor for the particular frame size indicated on the motor nameplate.

6.3 MECHANICAL SEAL

Mechanical seals require no special attention. The mechanical seal is fitted with a flush line. The seal is flushed from discharge of the pump casing on Design Envelope 4200H pumps and from the suction on Design Envelope 4280 pumps.

The Design Envelope 4200H pump is flushed from the pump discharge because the mechanical seal chamber is isolated from the liquid in the pump by a throttle bushing. Because the seal chamber is isolated, seal environmental controls such as filters and separators, when installed in the Design Envelope 4200H flush line are very effective, as only the seal chamber needs cleansing, and will prolong seal life in HVAC systems.

Do not run the pump unless properly filled with water as the mechanical seals need a film of liquid between the faces for proper operation.

Mechanical seals may weep slightly at start-up. Allow the pump to continue operating for several hours and the mechanical seal to seat properly prior to calling for service personnel.

WARNING



Hydronic system components may be pressurized which, if suddenly released, can cause serious injury or death. When performing any kind of service to the pump, the pressure must be released in the system and the unit should be properly drained before starting any service work.

**6.3.1 MECHANICAL SEAL REPLACEMENT
INSTRUCTIONS FOR RIGID SPLIT- COUPLED
PUMPING UNITS (SERIES 4300, 4200H &
4322)**

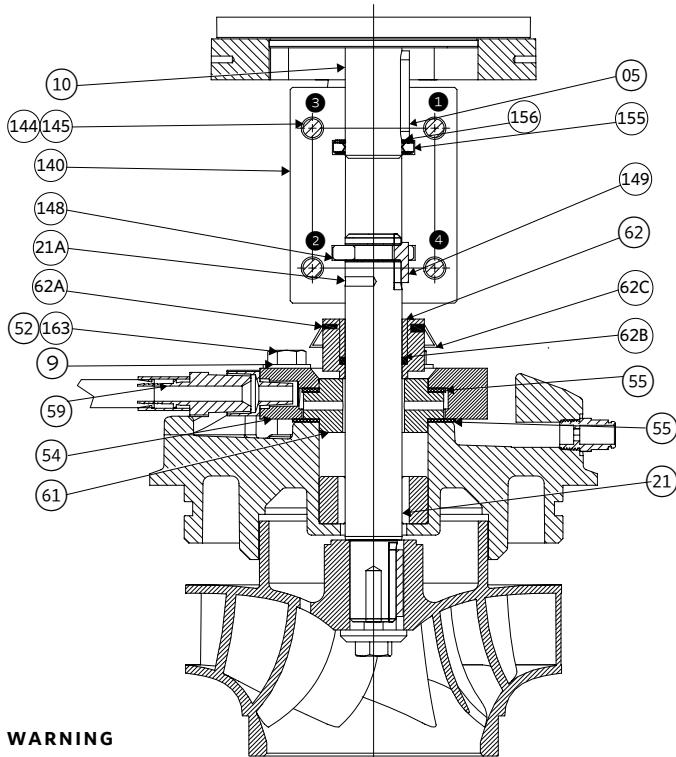

WARNING



When reinstalling the clamp, tighten the clamp nut to 90-100 in-lb torque.

CAUTION



Do not use oil, Vaseline or other petroleum or silicon based products for seal elastomer lubrication. Otherwise elastomer swelling may occur, causing seal failure. Recommended: International Products Corp p-80 Rubber Lubricant Emulsion in USA & UK www.ipcol.com

Seal Removal

An important feature of the rigid split-coupled pump is that the design permits removal of the mechanical seal without disturbing the pump, motor or electrical wiring.

- A** Disconnect the power supply at the main switch and close the isolating valves on the suction and discharge. Empty casing by removing drain plug(s) located at the bottom.
- B** Loosen off the seal collar set screws (62A) Remove the coupling screws and lock washer (144,145) and separate the coupling halves (140). Remove the motor shaft key (05) and the pump shaft key (149).

Do not remove motor collar (155) for seal replacement.

- C** Remove the mechanical seal rotating assembly (62)

through the gap between the pump and motor shafts..

- D** Disconnect the seal flush piping (59) from pump discharge. Mark seal gland plate (54) position. Remove the seal gland plate bolts and washer (lock washer) (52,163) and seal gland plate (54). Remove the stationary seat (61) and seat gaskets (55).

Seal replacement

Handle mechanical seal carefully to protect seal faces from damage. Do not contaminate seal faces with finger prints

- E** Replace the stationary seat (61) and gaskets (55) from mechanical seal package, aligning the seat flush hole with the seal gland plate flush line connection. Ensure the large diameter gasket is on the bottom. Replace seal gland plate (54) and tighten the seal gland plate bolts (52,163) evenly and diagonally to 5 (ft. lbs) for 0.75" seal size.
- F** When installing the mechanical seal (62), ensure parts are perfectly clean.
- G** Apply a small amount of temporary rubber lubricant emulsion to the O-ring (62B). Carefully slide the mechanical seal rotating assembly (62) down the shaft onto the stationary seat (61). Do not tighten the set screws (62A) on the side of the mechanical seal yet. Do not remove holding clips (62C).

If motor is replaced: Loosen set screws (56) on motor shaft collar (155) and remove from old motor shaft. To position the collar (155) correctly on the new motor shaft, temporarily fit motor shaft collar (155) into groove of the keyed coupling half. Slide collar, with coupling half onto new motor shaft until end of shaft lines up with line scored into coupling. Tighten the visible set screws (156) in the collar (155) enough to hold the collar in place on the shaft and remove the coupling half. Tighten all collar set screws (156) evenly and diagonally.

- H** Fit the motor shaft key (05) and the pump shaft key (149) then install the keyed coupling half (140) first.

NOTE:

For easier coupling installation, motor and pump shaft keys (05 & 149) should be 180 degrees from the working area. To automatically locate the impeller in the pump, insert the coupling screw Allan wrench into positioning hole (21A) and lift pump shaft until the pump shaft collar is positioned in the coupling groove, then rotate shaft to locate the pump shaft key (149) into blind keyway in coupling.

- I** Place the second coupling half into position and tighten the coupling screws (144,145) following the tightening pattern shown on the illustration (1-2-3-4).

NOTE:

Snug fit the coupling screws and confirm even gap spacing between coupling halves, then firmly tighten coupling screws following the tightening pattern illustrated. Then push (or slide) mechanical seal (62) firmly onto the stationary seat (61) and tighten the set screws (62A) by a torque wrench to 5 (ft. lbs). The mechanical seal is now pre-set at the correct working length.

- J Replace the seal flush piping (59) and drain plug(s). Open all isolating valves prior to operating pump(s). Reconnect power supply.

**6.3.2 MECHANICAL SEAL REPLACEMENT
INSTRUCTIONS FOR CLOSE-COUPLED PUMPING
UNITS (SERIES 4380, 4280 & 4372)**

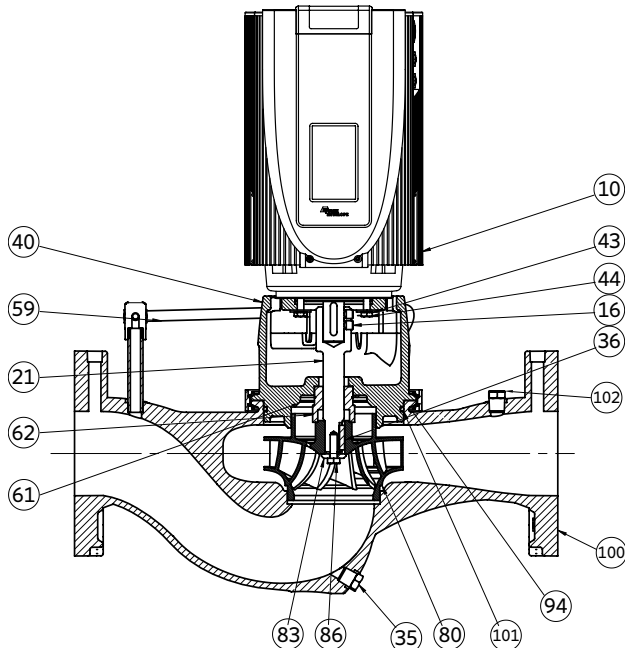

The close-coupled or motor mounted type Vertical in-Line pumps use vertical shaft-down ball bearing motors (integrated motors and drives). Each pump and motor unit is pipe mounted and as such relies on the piping only for support. The piping support is designed for the weight of the piping, liquid, pump and motor and other pipe fittings. The pumping unit should not be independently secured to the building structure. If the pump is mounted separately to any structure, the pump must be isolated from the piping with flexible piping connections. For units with larger motors it is advisable to install a permanent device for lifting the rotating assembly out of the pipe mounted casing to service the unit.

Breakdown procedures:

CAUTION



Exercise extreme care when handling power wiring. Ensure that the fuses are removed or breaker disconnected in the power line to the motor. Power disconnect should be within sight of the pump being serviced and tagged with the reason for disconnection.

A Electrical wiring

If the pump and/or motor assembly is to be serviced on a bench, the motor wiring must be disconnected.

B Isolation valves

If the system is not drained: Ensure that the suction and discharge piping isolation valves are closed. Remove drain plug (35) from the bottom of the casing and drain the pump.

C Prepare assembly for removal

Secure the motor (10) by lifting straps to an overhead chain fall or similar lifting device. The device must be designed to lift the weight of the unit safely. Raise the lifter to bring the lifting straps taut. Disconnect the flush/vent flex hose from pump suction and secure flex hose to one side. Remove the clamp ring between casing (100) and adapter (40). Care should be taken not to apply pressure to the outside diameter of the adapter, to prevent possible breakage, outside pressure should be on the casing only.

D Remove rotating assembly

The rotating assembly [motor, adapter and impeller] (10, 40 & 80) may now be lifted out of the casing.

E Rotating assembly notes

The impeller (80) is fastened directly to the stub shaft and must be removed to replace the mechanical seal assembly (61/62). This may be accomplished on a safe surface near the installation, or more conveniently on a work bench.

F Impeller cap screw

The impeller (80) should be prevented from rotating while the impeller cap screw (86) is loosened. A heavy screwdriver or pry bar may be inserted in between the impeller blades to enable the impeller cap screw (86) to be backed off with a socket wrench [**NOTE:** be careful not to damage the impeller blades]. Remove the impeller cap screw and washer (86 & 83).

G Pump impeller

Using wheel pullers, with the jaws behind the rear shroud of the impeller (80) [Behind a vane at each side] pull the impeller free of the pump shaft. Impeller that is difficult to remove may be loosened by heating the impeller hub with a torch during the pulling process to remove the impeller from the motor shaft.

H Remove mechanical seal from motor shaft

The mechanical seal spring usually comes free with the impeller. The mechanical seal rotating element [seal head] (62) must be pried loose with pry bars or screwdrivers, placed under each side of the seal drive band. Leverage is applied against the adapter. Once loosened, the seal may be pulled free of the shaft.

Do not damage the carbon face when removing the rotating element [seal head]. It may be needed for analysis if seal failure investigation is required.

I Remove seal seat from adapter

The stationary seat (61) typically O-ring or L-cup mounted Silicon Carbide material, is pried loose from the recess in the adapter. If the seat cannot be removed in this manner, remove the motor cap screws and washers [lock washers] (43, 44) and separate the adapter (40) from the motor (10). A screwdriver may then be used to push the seat out of the adapter from the rear.

J Remove old casing gasket

The former adapter O-ring should be scraped from the adapter, leaving clean surfaces [groove] for the new O-ring. [A standard putty knife and wire brush are useful for this purpose].

Assembly Procedures

K Replace mechanical seal

- Clean the shaft stub (21) surface, ensuring all the former seal elastomer pieces have been removed. Inspect for damage. Replace if necessary.
- Install a new stationary seat (61) in the adapter cavity, being sure the lapped (polished) side of the insert is facing up. Ensure that the cavity has been thoroughly cleaned. Lubricate the stationary seat O-ring or L-cup with a small amount silicon or glycerine lubricant and firmly press down straight and even into the adapter cavity. Do not press the seat in with bare fingers or hammer it down, use a clean cloth or the cardboard disc typically supplied with the seal packaging. Contamination of the polished and lapped stationary seat face could cause leakage. If the adapter was removed from the motor, taking care that the stationary seat is carefully guided over the stub shaft when assemble the adapter back onto the motor.
- Lubricate the inside of the rotating seal [seal head] (62) with a small amount of silicon or glycerine lubricant and slide onto the stub shaft (21) with a twisting motion, carbon face first, until the carbon face is pressed firmly against the stationary seat (61). Firmly press on the rotating seal [seal head] metal parts with a screw driver all the way around

the seal which will ensure that the faces are mated properly. Remove the spring retainer from the seal spring and place the seal spring over the rotating seal.

L Replace pump impeller

- Install the impeller key on the shaft and place the seal spring retainer onto the impeller hub register. Slide the impeller in place on the stub shaft.
- Take care and ensure that the seal spring is kept in place on the seal rotating assembly and fits well into the retainer on the impeller hub.

M Tighten impeller cap screw

It is good practice to replace self locking screws, once removed. Install the impeller cap screw and washer (83 & 86). Hold the impeller the same way as when the cap screw was successfully loosened (pry bar or screw driver placed carefully between the impeller blades) and tighten the cap screw with a socket wrench.

N Install new adapter O-ring

Insert new adapter O-ring into the O-ring groove of the adapter and apply silicon or glycerine lubricant around the O-ring.

O Clamp Ring

Insert Clamp Ring thru the impeller and adapter flange. Tighten the nut on the clamp ring to 90-100 lbs-in.

P Lower rotating assembly into place

The rotating assembly motor, adapter and impeller combination may now be lowered into the casing.

Q Casing and adapter clamp-ring

The casing and adapter clamp-ring is now installed and tightened with a wrench.

Reconnect the flush/vent flex hose assembly [check for damage and replace if necessary].

R Isolation valves

Replace the casing drain plug and open the suction and discharge isolation valves.

S Motor wiring

- The motor conduit and its wiring are now replaced. If the motor is new, double check that the voltage and RPM are identical to the original motor.
- Be sure to check rotation of the motor after rewiring if the motor is three phase and correct if necessary, by switching any two lead wires.
- Ensure that the pump is filled with water before operating to check rotation.

T Conduit Box Cover

The conduit box cover is replaced after checking the motor rotation. The pump may now be placed in operation.

6.4 SYSTEM CLEANLINESS

Before starting the pump, the system must be thoroughly cleaned, flushed and drained and replenished with clean liquid.

Welding slag and other foreign materials, Stop Leak and cleaning compounds and improper or excessive water treatment are all detrimental to the pump internals and sealing arrangement.

Proper operation cannot be guaranteed if the above conditions are not adhered to.

7.0 WARNINGS AND ALARMS

7.1 ALARM SUMMARY FOR INTERFACES

| ALARM NUMBER | NAME | ALARM DESCRIPTION |
|--------------|----------------------------|--|
| 1 | vSD over temperature | The temperature of a vSD or motor component is exceeding the thermal alarm limit. Turn off the power to the pump and verify that the motor, fan and vSD cooling is functioning correctly. Verify that the pump is not overloaded. Wait until hot components have cooled before returning to service and if the alarm persists after powering up contact an Armstrong Technical Service representative. |
| 2 | vSD over current | The vSD has detected current exceeding the safe limit. Turn the pump off. (If there is a discharge from the output phases to earth it can be verified by checking for any faults with a megohmmeter between ground and the motor leads). If a current limit has been exceeded in the vSD check that the motor can be turned. If the pump is being overloaded reduce the pump speed using hand mode control. If the alarm persists after powering up contact an Armstrong Technical Service representative. |
| 3 | External vSD voltage | The voltage into the vSD is out of range. Verify that the correct voltage required to operate the vSD is present by measuring each of the 3 phases. If the alarm persists after cycling power to the pump, contact an Armstrong Technical Service representative. |
| 4 | Internal vSD voltage | An internal voltage generated by vSD is out of range. If the alarm persists after cycling power to the pump, contact an Armstrong Technical Service representative. |
| 5 | Internal vSD | An internal error in the vSD has occurred. If the alarm persists after cycling power to the pump, contact an Armstrong Technical Service representative. |
| 6 | vSD parameter | One or more of the parameters to control the vSD are not correct. Check the settings on the control card. If the alarm persists after cycling power to the pump, contact an Armstrong Technical Service representative. |
| 7 | vSD startup | An error occurred during the startup of the motor. Turn off the power to the pump and verify that the motor can be turned by using hand mode control. If the alarm persists after powering up contact an Armstrong Technical Service representative. |
| 8 | Other vSD | There has been an unknown alarm condition generated by the vSD. If the alarm persists after cycling power to the pump, contact an Armstrong Technical Service representative. |
| 9 | vSD communication | There is a communication issue between the control card and vSD. Turn off the power to the pump and check the connections between the control card and the vSD. |
| 10 | vSD speed | The speed set by the vSD is not within tolerance. If the alarm persists after cycling power to the pump, contact an Armstrong Technical Service representative. |
| 11 | vSD initialization failure | The control card was not able to receive the initial parameters correctly. Please try to restart the pump. If the alarm persists after restart, contact an Armstrong Technical Service representative. |

7.2 WARNING SUMMARY FOR INTERFACES

| WARNING NUMBER | NAME | WARNING DESCRIPTION |
|----------------|----------------------------|---|
| 1 | vSD over temperature | The temperature of a vSD or motor component is near the thermal warning limit. Check that the motor, fan and vSD cooling is functioning correctly. Verify that the pump is not overloaded. If the warning persists, contact an Armstrong Technical Service representative. |
| 2 | vSD over current | The vSD has detected current exceeding the warning limit. Turn the pump off. (If there is a discharge from the output phases to earth it can be verified by checking for any faults with a megohmmeter between ground and the motor leads.) If a current limit has been exceeded in the vSD check that the motor can be turned. If the pump is being overloaded reduce the pump speed using hand mode control. If the warning persists after powering up contact an Armstrong Technical Service representative. |
| 3 | External vSD voltage | The voltage into the vSD is out of range. Verify that the correct voltage required to operate the vSD is present by measuring each of the 3 phases. If the warning persists, contact an Armstrong Technical Service representative. |
| 4 | Internal vSD voltage | An internal voltage generated by vSD is out of range. If the warning persists, contact an Armstrong Technical Service representative. |
| 5 | Internal vSD | An internal warning in the vSD has occurred. If the warning persists, contact an Armstrong Technical Service representative. |
| 6 | Reserved | |
| 7 | vSD startup | A warning occurred during the startup of the motor. Turn off the power to the pump and verify that the motor can be turned using hand mode control. If the warning persists after powering up contact an Armstrong Technical Service representative. |
| 8 | Other vSD | There has been an unknown warning condition generated by the vSD. If the alarm persists, contact an Armstrong Technical Service representative. |
| 9 | vSD communication | There is a communication issue between the control card and vSD. |
| 10 | vSD speed | The speed set by the vSD is not within tolerance. If the alarm persists, contact an Armstrong Technical Service representative. |
| 11 | vSD wiring | There is an issue in wiring to the vSD. Check the wiring to the motor from the vSD. If any I/O are used on the vSD, verify that there is continuity and no shorts for the connections. |
| 12 | System over temperature | The temperature measured by the control card is approaching the recommended operating conditions. |
| 13 | System under temperature | The temperature measured by the control card is approaching the recommended operating conditions. |
| 14 | Battery under voltage | The battery voltage is low. Replace the battery with CR2032 type cell. |
| 15 | BMS communication loss | BMS communication has been lost. |
| 16 | vSD communication loss | The communication with the vSD and the control card has stopped. |
| 17 | Invalid vSD parameter | The control card has specified an invalid vSD parameter. |
| 18 | vSD initialization failure | The initialization of the vSD through Modbus has failed. Cycle power to the pump to re-initialize. |
| 19 | vSD speed set failure | The speed could not be set by the controller. Check the connections between the vSD and control card. |
| 20 | vSD start set failure | The controller could not start the motor. Check the connections between the vSD and control card. |
| 21 | Sensorless error | The sensorless map that was entered has an error please refer to the I & O Manual for further details. |
| 22 | Hand mode timeout | The pump has been in hand mode too long. Consider setting to automatic mode to save energy. |

8.0 FUSE AND WIRE RECOMMENDATION

Armstrong recommends UL 508 listed fast-acting, current-limiting fuses for upstream protection of installations within the NEC/UL jurisdiction.

Example fuses suitable for upstream protection are detailed below.

ARMSTRONG DISCONNECT SWITCH AND FUSE RATING - 1PH 200-240V INPUT POWER FOR USE WITH DESIGN ENVELOPE PERMANENT MAGNET MOTORS - FRAME 71

| RATED POWER | | DISCONNECT SWITCH RATING | FUSE RATING | FUSE CLASS TYPES | MAXIMUM DRIVER INPUT CURRENT (A) | |
|-------------|------|--------------------------|-------------|------------------|----------------------------------|---------|
| HP | KW | | | | 200 VAC | 240 VAC |
| 0.33 | 0.25 | 30A | 6A | CC FAST-ACTING | 2.0 | 1.6 |
| 0.5 | 0.37 | | 6A | | 2.6 | 2.0 |
| 0.75 | 0.55 | | 10A | J FAST-ACTING | 3.3 | 2.9 |
| 1 | 0.75 | | 10A | RK1 FAST-ACTING | 4.8 | 4.0 |
| 1.5 | 1.1 | | 15A | | 7.1 | 5.8 |
| 2 | 1.5 | | 20A | | 9.3 | 7.6 |

ARMSTRONG DISCONNECT SWITCH AND FUSE RATING - 3PH 200-240V INPUT POWER FOR USE WITH DESIGN ENVELOPE PERMANENT MAGNET MOTORS - DEPM

| RATED POWER | | DISCONNECT SWITCH RATING | FUSE RATING | FUSE CLASS TYPES | MAXIMUM DRIVER INPUT CURRENT (A) | |
|-------------|------|--------------------------|-------------|------------------|----------------------------------|---------|
| HP | KW | | | | 200 VAC | 240 VAC |
| 1 | 0.75 | 30A | 10A | CC FAST-ACTING | 3.1 | 2.7 |
| 1.5 | 1.1 | | 10A | | 4.2 | 3.7 |
| 2 | 1.5 | | 15A | J FAST-ACTING | 6.0 | 4.8 |
| 3 | 2.2 | | 20A | RK1 FAST-ACTING | 8.8 | 7.2 |
| 5 | 4 | | 30A | | 15.7 | 14.0 |
| 7.5 | 5.5 | 60A | 50A | J FAST-ACTING | 20.7 | 18.5 |
| 10 | 7.5 | | 60A | RK1 FAST-ACTING | 28.1 | 25.1 |

ARMSTRONG DISCONNECT SWITCH AND FUSE RATING - 3PH 200-240V INPUT POWER FOR USE WITH DESIGN ENVELOPE PERMANENT MAGNET MOTORS - FRAME 71

| RATED POWER | | DISCONNECT SWITCH RATING | FUSE RATING | FUSE CLASS TYPES | MAXIMUM DRIVER INPUT CURRENT (A) | |
|-------------|------|--------------------------|-------------|------------------|----------------------------------|---------|
| HP | KW | | | | 200 VAC | 240 VAC |
| 0.33 | 0.25 | 30A | 5 | CC FAST-ACTING | 1.5 | 1.2 |
| 0.5 | 0.37 | | 6 | | 2.1 | 1.8 |
| 0.75 | 0.55 | | 10 | | 2.9 | 2.6 |
| 1 | 0.75 | | 10 | | 3.5 | 3.1 |
| 1.5 | 1.1 | | 15 | | 4.8 | 4.6 |
| 2 | 1.5 | | 20 | | 6.4 | 5.9 |

ARMSTRONG DISCONNECT SWITCH AND FUSE RATING - 3PH 200-240V INPUT POWER FOR USE WITH DESIGN ENVELOPE PERMANENT MAGNET MOTORS - DEPM2

| RATED POWER | | DISCONNECT SWITCH RATING | FUSE RATING | FUSE CLASS TYPES | MAXIMUM DRIVER INPUT CURRENT (A) | |
|-------------|-----|--------------------------|-------------|------------------|----------------------------------|---------|
| HP | KW | | | | 200 VAC | 240 VAC |
| 3 | 2.2 | 30A | 20A | CC FAST-ACTING | 7.4 | 6.4 |
| 5.5 | 4 | | 30A | | 14.2 | 12.6 |
| 7.5 | 5.5 | | 30A | | 19.0 | 16.6 |
| 10 | 7.5 | | 30A | | 26.2 | 23.0 |

ARMSTRONG DISCONNECT SWITCH AND FUSE RATING - 3PH 380V-480V INPUT POWER FOR USE WITH DESIGN ENVELOPE PERMANENT MAGNET MOTORS - FRAME 71

| RATED POWER | | DISCONNECT SWITCH RATING | FUSE RATING | FUSE CLASS TYPES | MAXIMUM DRIVER INPUT CURRENT (A) | |
|-------------|------|--------------------------|-------------|------------------|----------------------------------|---------|
| HP | KW | | | | 380 VAC | 480 VAC |
| 0.33 | 0.25 | 30A | 5A | CC FAST-ACTING | 1.3 | 0.8 |
| 0.5 | 0.37 | | 5A | | 1.6 | 1.1 |
| 0.75 | 0.55 | | 6A | | 1.9 | 1.5 |
| 1 | 0.75 | | 6A | 2.5 | 2.0 | |
| 1.5 | 1.1 | | 10A | 4.1 | 3.5 | |
| 2 | 1.5 | | 10A | J FAST-ACTING | 5.3 | 3.9 |
| 3 | 2.2 | | 10A | RK1 FAST-ACTING | 6.5 | 5.8 |
| 4 | 3 | | 15A | | 6.1 | 4.9 |
| 5 | 4 | | 20A | | 9.2 | 7.1 |
| 7.5 | 5.5 | | 25A | | 12.5 | 8.2 |
| 10 | 7.5 | 30A | 18.5 | 14.5 | | |

ARMSTRONG DISCONNECT SWITCH AND FUSE RATING - 3PH 380V-480V INPUT POWER FOR USE WITH DESIGN ENVELOPE PERMANENT MAGNET MOTORS - DEPM

| RATED POWER | | DISCONNECT SWITCH RATING | FUSE RATING | FUSE CLASS TYPES | MAXIMUM DRIVER INPUT CURRENT (A) | |
|-------------|------|--------------------------|-------------|------------------|----------------------------------|---------|
| HP | KW | | | | 380 VAC | 480 VAC |
| 1 | 0.75 | 30A | 6A | CC FAST-ACTING | 2.1 | 1.7 |
| 1.5 | 1.1 | | 6A | | 2.8 | 2.3 |
| 2 | 1.5 | | 10A | 4.8 | 4.1 | |
| 3 | 2.2 | | 10A | J FAST-ACTING | 6.5 | 5.8 |
| 4 | 3 | | 15A | RK1 FAST-ACTING | 6.1 | 4.9 |
| 5 | 4 | | 20A | | 9.2 | 7.1 |
| 7.5 | 5.5 | | 25A | | 12.5 | 8.2 |
| 10 | 7.5 | | 30A | 18.5 | 14.5 | |

ARMSTRONG DISCONNECT SWITCH AND FUSE RATING - 3PH 380V-480V INPUT POWER FOR USE WITH DESIGN ENVELOPE PERMANENT MAGNET MOTORS - DEPM2

| RATED POWER | | DISCONNECT SWITCH RATING | FUSE RATING | FUSE CLASS TYPES | MAXIMUM DRIVER INPUT CURRENT (A) | |
|-------------|-----|--------------------------|-------------|------------------|----------------------------------|---------|
| HP | KW | | | | 380 VAC | 480 VAC |
| 3 | 2.2 | 30A | 10A | CC FAST-ACTING | 3.9 | 3.2 |
| 4 | 3 | | 10A | | 5.4 | 4.2 |
| 5.5 | 4 | | 15A | | 7.1 | 5.7 |
| 7.5 | 5.5 | | 15A | | 9.5 | 7.6 |
| 10 | 7.5 | | 25A | | 13.6 | 11.3 |
| 15 | 11 | | 30A | | 18.8 | 15.5 |

ARMSTRONG DISCONNECT SWITCH AND FUSE RATING - 3PH 575-600V INPUT POWER FOR USE WITH DESIGN ENVELOPE PERMANENT MAGNET MOTORS - DEPM MOTORS

| RATED POWER | | DISCONNECT SWITCH RATING | FUSE RATING | FUSE CLASS TYPES | MAXIMUM DRIVER INPUT CURRENT (A) | |
|-------------|------|--------------------------|-------------|------------------|----------------------------------|---------|
| HP | KW | | | | 575 VAC | 600 VAC |
| 1 | 0.75 | 30A | 5A | CC FAST-ACTING | 1.6 | 1.3 |
| 1.5 | 1.1 | | 6A | | 2.2 | 1.8 |
| 2 | 1.5 | | 8A | | 2.0 | 1.6 |
| 3 | 2.2 | | 10A | | 3.4 | 2.8 |
| 5 | 4 | | 20A | | 5.5 | 4.9 |
| 7.5 | 5.5 | | 25A | | 7.2 | 6.0 |
| 10 | 7.5 | 30A | 9.8 | 9.4 | | |

ARMSTRONG DISCONNECT SWITCH AND FUSE RATING - 3PH 575-600V INPUT POWER FOR USE WITH DESIGN ENVELOPE PERMANENT MAGNET MOTORS - DEPM2 MOTORS

| RATED POWER | | DISCONNECT SWITCH RATING | FUSE RATING | FUSE CLASS TYPES | MAXIMUM DRIVER INPUT CURRENT (A) | |
|-------------|------|--------------------------|-------------|------------------|----------------------------------|---------|
| HP | KW | | | | 575 VAC | 600 VAC |
| 1 | 0.75 | 30A | 5A | CC FAST-ACTING | 1.6 | 1.5 |
| 1.5 | 1.1 | | 6A | | 2.1 | 2.0 |
| 2 | 1.5 | | 6A | | 2.6 | 2.6 |
| 3 | 2.2 | | 6A | | 3.5 | 3.2 |
| 5 | 4 | | 15A | | 5.7 | 5.3 |
| 7.5 | 5.5 | | 15A | | 7.5 | 7.4 |
| 10 | 7.5 | 30A | 10.8 | 10.1 | | |

All cabling and must comply with national and local regulations on cable cross-sections and ambient temperature

9.0 PUMP MANAGER

Pump Manager is a cloud based analytics service providing real time alerts and insights on the flow and the system's efficiency. Pump Manager provides unique and critical insights to drive savings in energy, maintenance, emergency repairs and down-time costs.

Features

Secure IoT Connectivity

Plug 'n play setup, no LAN connection required. Pump connected to the IBM Watson analytics platform cloud via a 4G LTE router with built-in cellular modem. Authentication key and 1-way push notifications only with no inbound communication to pumps make for safe connection

Real Time Alerts

Know of problems before they occur. Pump Manager will alert you when something is wrong

Performance Reports

You can now view operation trends and make data informed decisions

Predictive Maintenance

The pump will advise which parts it needs! And tell you where to buy them as well

Building Management System Integration

Integrate the pump data to your building automation system via API so you can view all your assets in one place

Benefits

Lower Operating Costs

- Optimal operation for maximum energy efficiency
- Lower OpEx costs

Increase Availability & Reliability

- Reduce unexpected failures
- Early problem detection
- Faster return to service

Improve Comfort and Productivity

- Keep flows in the desired range, reducing temperature swings

Improve Building Resilience and Future Decisions

- Make informed capital investment decisions

Start Now in Two Easy Steps

<http://armstrongfluidtechnology.com/en/registration> OR info@armstrongfluidtechnology.com

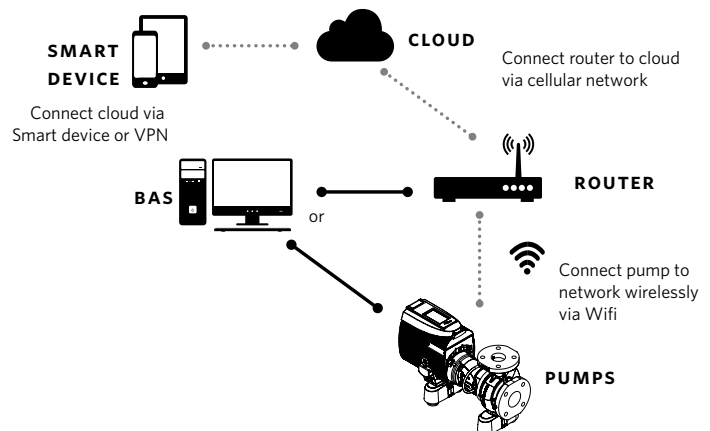

10.0 CONNECTIVITY KIT

Pump Manger integration procedure

This procedure describes the steps to connect an Armstrong Pump Manger router to a Design Envelope Pump with a DEPC controller.

Each site will be required to have a factory programmed router for data transfer (included with each Design Envelope Pump order).

Refer to **File No:** 100.8154 on Armstrong Corporate Website for full details.

TORONTO

23 BERTRAND AVENUE,
TORONTO, ONTARIO,
CANADA, M1L 2P3
+1 416 755 2291

BUFFALO

93 EAST AVENUE, NORTH
TONAWANDA, NEW YORK,
U.S.A., 14120-6594
+1 716 693 8813

DROITWICH SPA

POINTON WAY, STONEBRIDGE CROSS
BUSINESS PARK, DROITWICH SPA,
WORCESTERSHIRE,
UNITED KINGDOM, WR9 0LW
+44 121 550 5333

MANCHESTER

WOLVERTON STREET, MANCHESTER
UNITED KINGDOM, M11 2ET
+44 161 223 2223

BANGALORE

#18, LEWIS WORKSPACE, 3RD FLOOR,
OFF MILLERS - NANDIDURGA ROAD,
JAYAMAHAL CBD, BENSON TOWN,
BANGALORE, INDIA 560 046
+91 80 4906 3555

SHANGHAI

UNIT 903, 888 NORTH SICHUAN RD.
HONGKOU DISTRICT, SHANGHAI
CHINA, 200085
+86 21 5237 0909

BEIJING

ROOM 1612, NANYIN BUILDING NO.2
NORTH EAST THRID RING ROAD
CHAOYANG DISTRICT, BEIJING,
CHINA 100027
+86 21 5237 0909

SÃO PAULO

RUA JOSÉ SEMIÃO RODRIGUES
AGOSTINHO, 1370 GALPÃO 6 EMBU
DAS ARTES, SAO PAULO, BRAZIL
+55 11 4785 1330

LYON

93 RUE DE LA VILLETTE
LYON, 69003 FRANCE
+33 4 26 83 78 74

DUBAI

JAFZA VIEW 19, OFFICE 402
P.O. BOX 18226 JAFZA,
DUBAI - UNITED ARAB EMIRATES
+971 4 887 6775

JIMBOLIA

STR CALEA MOTILOR NR. 2C
JIMBOLIA 305400, JUD.TIMIS
ROMANIA
+40 256 360 030

FRANKFURT

WESTERBACHSTRASSE 32,
D-61476 KRONBERG IM TAUNUS
GERMANY
+49 6173 999 77 55

ARMSTRONG FLUID TECHNOLOGY®
ESTABLISHED 1934

ARMSTRONGFLUIDTECHNOLOGY.COM