

# Design Envelope 4300 & 4380

Vertical In-line pumping  
unit with permanent  
magnet motors up to  
7.5 kW

Installation and  
operating instructions

File No: 101.801EC  
Date: SEPTEMBER 14, 2023  
Supersedes: 101.801EC  
Date: JUNE 12, 2023

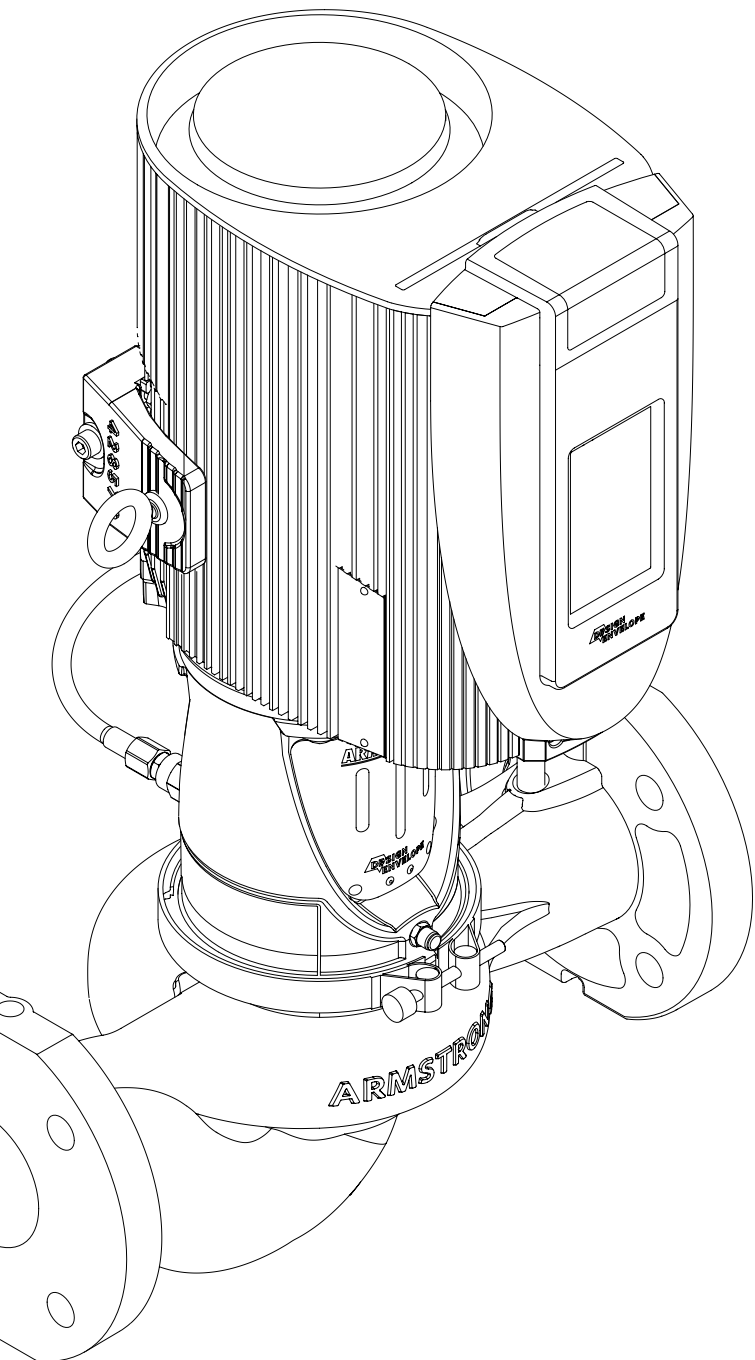

# CONTENTS

<b>1.0 MECHANICAL SETUP</b>	4	2.3.4.3 CONTROL TERMINAL WIRING FOR DEPM2 MOTORS	18
<b>1.1 PRECAUTIONS</b>	4	2.3.5 ANALOG / DIGITAL INPUTS	19
1.1.1 INSTRUCTIONS FOR SAFE USE	4	2.3.5.1 ANALOG / DIGITAL INPUTS FOR FRAME 71 MOTORS	19
1.1.2 AMBIENT TEMPERATURE	4	2.3.5.2 ANALOG / DIGITAL INPUTS FOR DEPM MOTORS	20
1.1.3 ENCLOSURE RATING	4	2.3.5.3 ANALOG / DIGITAL INPUTS FOR DEPM2 MOTORS	20
1.1.4 STORAGE	4	2.3.6 ANALOG / DIGITAL OUTPUT	20
1.1.5 WARRANTY	4	2.3.6.1 ANALOG OUTPUT FOR FRAME 71 MOTORS	20
1.1.6 UNCRATING	4	2.3.6.2 DIGITAL OUTPUT FOR FRAME 71 MOTORS	21
1.1.7 HANDLING DESIGN ENVELOPE 4300 & 4380 UNITS	5	2.3.6.3 ANALOG OUTPUT FOR DEPM MOTORS	21
<b>1.2 MECHANICAL INSTALLATION</b>	5	2.3.6.4 DIGITAL OUTPUT FOR DEPM MOTORS	21
1.2.1 LOCATION	5	2.3.6.5 ANALOG OUTPUT FOR DEPM2 MOTORS	21
1.2.2 INSTALLATION	5	2.3.6.6 DIGITAL OUTPUT FOR DEPM2 MOTORS	21
1.2.3 PUMP PIPING-GENERAL	8	2.3.7 RELAY OUTPUT	21
1.2.4 ALIGNMENT	8	2.3.7.1 RELAY OUTPUT FOR FRAME 71 MOTORS	21
<b>2.0 ELECTRICAL SETUP</b>	9	2.3.7.2 RELAY OUTPUT FOR DEPM MOTORS	21
<b>2.1 PRECAUTIONS</b>	9	2.3.7.3 RELAY OUTPUT FOR DEPM2 MOTORS	21
2.1.1 GROUND LEAKAGE CURRENT	9	2.3.9 SUPPLY FUSING	22
2.1.2 START/STOP OF PUMP	9	<b>2.4 DESIGN ENVELOPE PUMP CONTROLLER WIRING</b>	23
2.1.3 ADDITIONAL MOTOR PROTECTION	9	2.4.1 BATTERY	23
2.1.4 MOTOR THERMAL PROTECTION AND DERATING	9	2.4.2 ETHERNET CONNECTIVITY	23
<b>2.2 ELECTRICAL SPECIFICATION</b>	10	2.4.3 CAN BUS WIRING	23
2.2.1 DEPM	10	2.4.4 RS 485 WIRING	23
2.2.2 FRAME 71	11	2.4.5 NETWORKING OPTIONS	23
2.2.3 DEPM 2	12	<b>3.0 NETWORKING CONTROLS</b>	24
<b>2.3 ELECTRICAL INSTALLATION</b>	14	3.1 MODBUS REGISTER MAP - VERSION 1 - FOR FIRMWARE V1.16 AND OLDER	25
2.3.1 POWER WIRING	14	3.2 BACNET OBJECTS - VERSION 1 - FOR FIRMWARE V1.16 AND OLDER	27
2.3.1.1 POWER WIRING FOR FRAME 71 MOTORS - 1 PHASE	14	3.3 MODBUS REGISTER MAP - VERSION 2 - FOR FIRMWARE V1.17 AND NEWER	29
2.3.1.2 POWER WIRING FOR FRAME 71 MOTORS - 3 PHASE	14	3.4 BACNET OBJECTS - VERSION 2 - FOR FIRMWARE V1.17 AND NEWER	31
2.3.1.3 POWER WIRING FOR DEPM MOTORS	14	<b>4.0 OPERATION</b>	33
2.3.1.4 POWER WIRING FOR DEPM 2 MOTORS	14	4.1 START-UP CHECKLIST	33
2.3.3 THE MAIN COVER DISASSEMBLY	15	4.2 STARTING PUMP	33
2.3.3.1 MAIN COVER DISASSEMBLY - FRAME 71 MOTORS	15	4.2.1 AUTO FLOW BALANCING	33
2.3.3.2 THE MAIN COVER DISASSEMBLY- DEPM MOTORS	15		
2.3.3.3 THE MAIN COVER DISASSEMBLY-DEPM2 MOTORS	16		
2.3.4 CONTROL TERMINAL WIRING	17		
2.3.4.1 CONTROL TERMINAL WIRING FOR FRAME 71 MOTORS	17		
2.3.4.2 CONTROL TERMINAL WIRING FOR DEPM MOTORS	18		

<b>4.3 TOUCH SCREEN</b>	34	<b>5.13 SENSORED CONTROL</b>	51
4.3.1 LOGIN	34	5.13.1 ADDING DP SENSORS THROUGH LCD SCREEN	51
4.3.2 LOGOUT	34	5.13.2 ADDING DP SENSORS FROM WEBSERVER	51
4.3.3 ABOUT	35	<b>5.14 BYPASS VALVE CONTROL</b>	52
4.3.4 GENERAL SETTINGS	36	<b>6.0 MAINTENANCE</b>	54
4.3.5 MANUAL/AUTO MODE	37	<b>6.1 GENERAL CARE</b>	54
4.3.6 PUMP CONTROL	38	<b>6.2 LUBRICATION</b>	54
4.3.7 ALARMS & WARNINGS	40	<b>6.3 MECHANICAL SEAL</b>	54
4.3.8 TREND-GRAPH	41	6.3.1 MECHANICAL SEAL REPLACEMENT INSTRUCTIONS FOR RIGID SPLIT-COUPLED PUMPING UNITS (SERIES 4300 & 4322)	54
4.3.9 BRIGHTNESS ADJUSTMENT	41	6.3.2 MECHANICAL SEAL REPLACEMENT INSTRUCTIONS FOR CLOSE-COUPLED PUMPING UNITS (SERIES 4380 & 4372)	56
4.3.10 TOUCH SCREEN CALIBRATION	42	<b>6.4 SYSTEM CLEANLINESS</b>	58
4.3.11 DATA LOGGING	43	<b>7.0 WARNINGS AND ALARMS</b>	58
<b>4.4 WEB INTERFACE</b>	44	7.1 ALARM SUMMARY FOR INTERFACES	58
4.4.1 CONNECTING VIA ETHERNET	44	7.2 WARNING SUMMARY FOR INTERFACES	59
4.4.2 CONNECTING VIA WIFI	44	<b>8.0 FUSE AND WIRE RECOMMENDATION</b>	60
<b>4.5 DESIGN ENVELOPE FLOW READOUT TOLERANCE</b>	46	<b>9.0 PUMP MANAGER</b>	61
<b>4.6 NOISE LEVELS</b>	46	<b>10.0 CONNECTIVITY KIT</b>	61
<b>5.0 CONTROL MODES</b>	47		
5.1 CONSTANT FLOW	47		
5.2 CONSTANT PRESSURE	47		
5.3 LINEAR PRESSURE	47		
5.4 QUADRATIC CURVE CONTROL	47		
5.5 QUADRATIC CURVE CONTROL WITH MINIMUM FLOW PROTECTION	47		
5.6 QUADRATIC CURVE CONTROL WITH MAXIMUM FLOW PROTECTION	47		
5.7 QUADRATIC CURVE CONTROL WITH MINIMUM & MAXIMUM FLOW PROTECTION	48		
<b>5.8 PARALLEL SENSORLESS PUMP CONTROL (PSPC)</b>	48		
5.8.1 EMBEDDED PARALLEL SENSORLESS PUMP CONTROL FOR MULTIPLE PUMPS	48		
5.8.2 MODIFYING MOTOR RAMP UP AND DOWN TIME	49		
5.8.3 THREE DIFFERENT CONTROL MODES CAN BE ACCESSED	50		
5.8.4 FALLBACK PERCENTAGE OF MAXIMUM SPEED	50		
5.8.5 STANDBY PUMPS	50		
5.9 2*100% CAPACITY SPLIT UNITS	50		
5.10 ALTERNATION	50		
5.11 CONSTANT PRESSURE CONTROL	51		
5.12 DUAL SEASON SETUP	51		

**Note:** Document subject to change.

## 1.0 MECHANICAL SETUP

This manual contains specific information regarding the safe installation, operation and maintenance of Armstrong Design Envelope pumps. Read this manual carefully before installing or using the product. If clarification is needed on any point please contact Armstrong quoting the equipment serial number.

### 1.1 PRECAUTIONS

#### 1.1.1 INSTRUCTIONS FOR SAFE USE



No installation of this equipment should take place unless this document has been studied and understood.

Handling, transportation and installation of this equipment should only be undertaken by trained personnel with proper use of lifting equipment. See later diagrams for lifting advice. Refer to the pump nameplate for pump speed, pressure and temperature limitations. The limits stated must not be exceeded without written permission from Armstrong.

#### 1.1.2 AMBIENT TEMPERATURE



Install the Design Envelope unit with adequate access for routine maintenance. A minimum of 50 mm (2") clearance is required at the fan inlet to facilitate airflow. Where several Design Envelope units are installed in close proximity, care must be taken to ensure that there is no re-circulation of exhausted warm air.



To avoid the DEPM unit getting overheated, the ambient temperature is not to exceed the average daily temperature. Operating in higher ambient temperatures will require derating of the DEPM unit (See section 2.1.4 for details).

Under normal operating conditions the pump surface temperature may reach 68°C /155°F (Restricted Zone) to 80°C /176°F (Unrestricted Zone). Steps should be taken to minimise contact or warn operators/users that normal operating conditions will be exceeded. In certain cases, where the temperature of the pumped liquid exceeds the above stated temperature levels, pump casing temperatures may exceed 100°C /212°F and notwithstanding pump insulation techniques appropriate measures must be taken to minimise risk for operating personnel.

#### 1.1.3 ENCLOSURE RATING

The standard enclosure rating for Design Envelope 4300 and Design Envelope 4380 integrated controls is IP55. If the pump is to be installed in a wet or dusty environment, then the IP66 enclosure is available. IP66 units are supplied with a touchscreen cover to protect the interface from UV degradation, and a weather shield to protect the motor fan from freezing rain or snow.

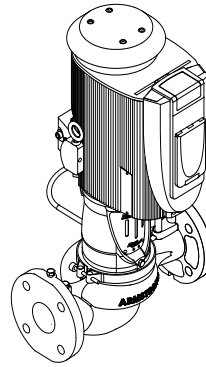

#### 1.1.4 STORAGE

Pumps not immediately placed into service, or removed from service and stored, must be properly prepared to prevent excessive rusting. Pump port protection plates must not be removed until the pump is ready to connect to the piping.

Rotate the shaft periodically (at least monthly) to keep rotating element free and bearings fully functional.

For long term storage (longer than three months), the pump must be placed in a vertical position in a dry environment.

Internal rusting can be prevented by removing the plugs at the top and bottom of the casing and drain or air blow out all water to prevent rust buildup or the possibility of freezing. Be sure to reinstall the plugs when the unit is made operational. Rustproofing or packing the casing with moisture absorbing material and covering the flanges is acceptable. When returning to service be sure to remove the drying agent from the pump.

#### 1.1.5 WARRANTY

Armstrong's warranty period for Design Envelope pumps is [18] months from date of shipment, or [12] months from date of installation, whichever comes first. Please refer to File 9.10UK / 9.10IN for full terms and conditions. To receive an additional six [6] months of standard coverage, the owner may register the pump unit at [www.armstrongfluidtechnology.com/warrantyregistration](http://www.armstrongfluidtechnology.com/warrantyregistration)

#### 1.1.6 UNCRATING

Armstrong Design Envelope 4300 & 4380 Vertical In-Line pumps are thoroughly inspected before shipment to assure they meet with your order requirements. After removing the pump from the packaging, make sure the equipment is in good order and that all components are received as called for on the packing list. Any shortages or damage should be reported immediately. Use extreme care in handling the unit, placing slings and hooks carefully so that stress will not be imposed on the integrated controls, pump or motor. Never place cable slings around the pump shaft or integrated controls. The hoist rings should be used to lift the complete pump assembly.



### 1.1.7 HANDLING DESIGN ENVELOPE 4300 & 4380 UNITS

To handle Design Envelope 4300 & 4380 units after they have been received on site, uncover the units and secure the pallet; then hook straps as detailed below and in **FIG. 1.1.1**, and carefully lift the pumping unit. Connect the lifting straps around the lifting rings on each side of the integrated motor. The pumping unit will not free-stand on the casing ribs. Extra care is required to ensure the integrated controls do not get damaged during lifting and installation.

As the lifting device is engaged (using a spacer bar if necessary) and the straps tighten, ensure no part of the strapping is touching any part of the control or motor fan cover.

**FIG. 1.1.1**

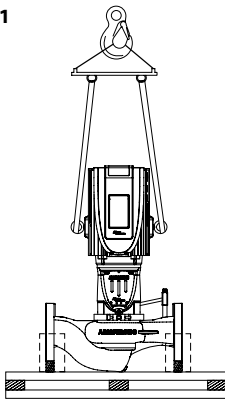

**IMPORTANT:**



Do not run the pump for any length of time under very low flow conditions at the maximum speed or with the discharge valve closed.

To do so could cause the water in the casing to reach superheated steam conditions and will cause premature failure; it can also result in serious and dramatic damage to the pump and surrounding area.

## 1.2 MECHANICAL INSTALLATION

### 1.2.1 LOCATION

In open systems, locate the unit as close as practical to the liquid being pumped, with a short, direct suction pipe. Ensure adequate space is left above and around the unit for operation, maintenance, service and inspection of parts.

In closed systems, where possible, the pumps should be installed immediately downstream of the expansion tank / make-up connection. This is the point of zero pressure change and is necessary for effective pump operation. Do not install more than one expansion tank connection into any closed hydronic system.

Electric motor driven pumps should not be located in damp or dusty locations without special protection.

Airflow into the motor and/or motor fan should not be obstructed.

It is good practice to leave sufficient space around equipment for operation, maintenance, and service needs.

### 1.2.2 INSTALLATION

When installing vertical in-line pumps, an important consideration to accrue full added-value from the pump design is to ensure that the pump is pipe-mounted and free to **float** with any movement, expansion and contraction of the piping. If a Vertical In-Line pump uses supports that rest on the base structure, it is imperative that no pipe strain is imposed on the pump flanges. Tell-tale pieces of equipment such as springs or **waffle** style neoprene isolation pads that distort with pressure to indicate added piping weight, should be used under pump supports should the pump not be truly pipe mounted.

#### A HANGER SUPPORTED PIPE MOUNTED

4300 & 4380 Vertical In-Line pumps may be installed directly in the system piping with no additional support. Pipe hangers are simply sized for the additional weight of the pumping unit. Many pumps are installed in this manner and can be mounted at sufficient height to take zero floor space.

**FIG. 1.2.1**

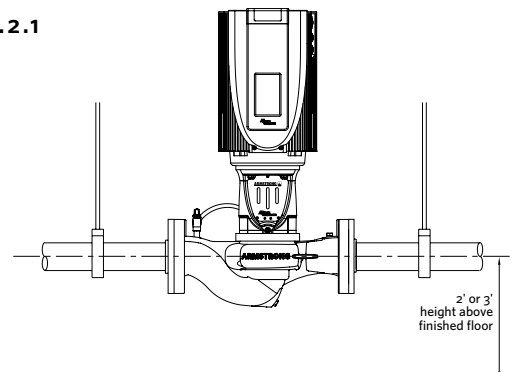

For application with no suction guide, straight pipe of a length equivalent up to 4 times its diameter for 1.5-6" pumps and 6 times diameter for 8" to 12" pumps will be required.

#### B PIPE MOUNTED SUPPORTED AT CEILING

Piping in many mechanical rooms is hung close to the ceiling and larger pumps are mounted near ground level for ease of maintenance. **FIG. 1.2.2** illustrates such an arrangement with the piping supported at the ceiling and the VIL unit installed with an Armstrong Suction Guide and Flo-Trex valve. Many very large VIL pumps are installed in this manner.

**FIG. 1.2.2**

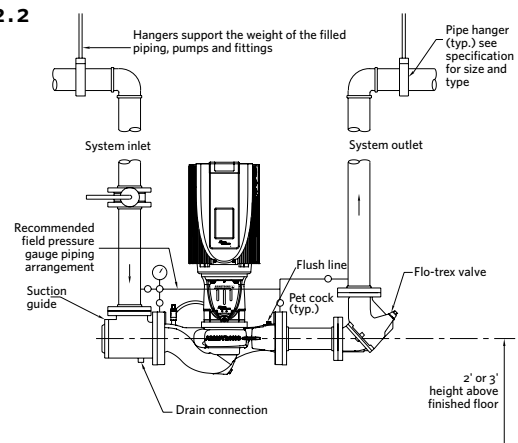

**C DISCHARGE ELBOW FOR MINIMUM FOOTPRINT**

Should additional space saving be required the discharge spool piece may be replaced by a long-radius elbow.

**FIG. 1.2.3**

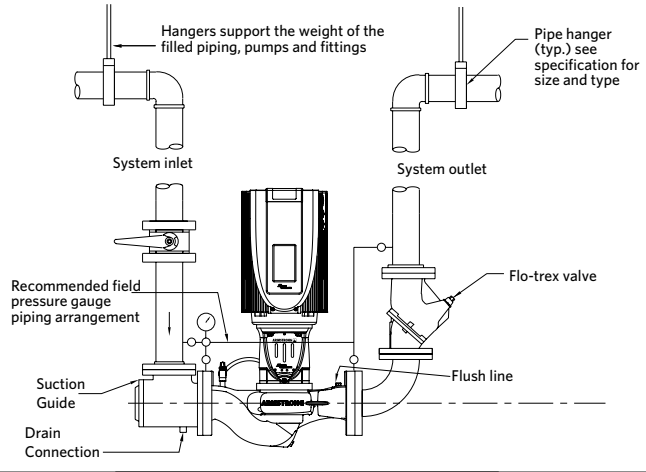

**D WITH ADDITIONAL PIPE SUPPORTS**

Fig 1.2.4 illustrates a similar arrangement to Fig 1.2.2 with additional floor mounted pipe-stools isolated from the structure by waffle style neoprene isolation pads under the Armstrong Suction Guide and Flo-Trex valve.

**FIG. 1.2.4**

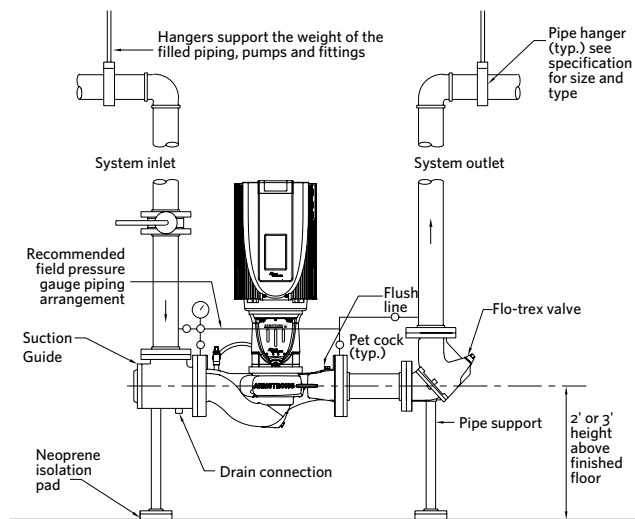

**E FLOOR SADDLE SUPPORT**

Floor mounted saddle supports (FIG. 1.2.5) are typical for condenser water pumps where the cooling tower base is at the mechanical room elevation.

**FIG. 1.2.5**

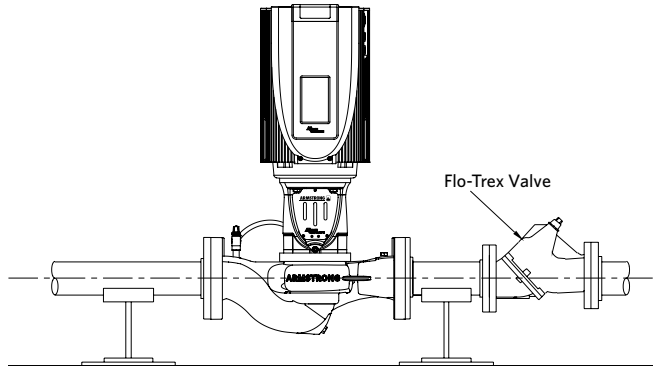

For application with no suction guide, straight pipe of a length equivalent up to 4 times its diameter for 1.5-6" pumps and 6 times diameter for 8" to 12" pumps will be required.

**F WITH STANCHION PLATES**

Where required, additional floor support may be used as shown in FIG. 1.2.6 Note that the pump should not be rigidly attached to the column. Leave a small gap between pump and column or install a 'waffle' isolation pad under the pump. It is critical that piping be installed in such a manner that the pump does not become a pipe support.

**FIG. 1.2.6**

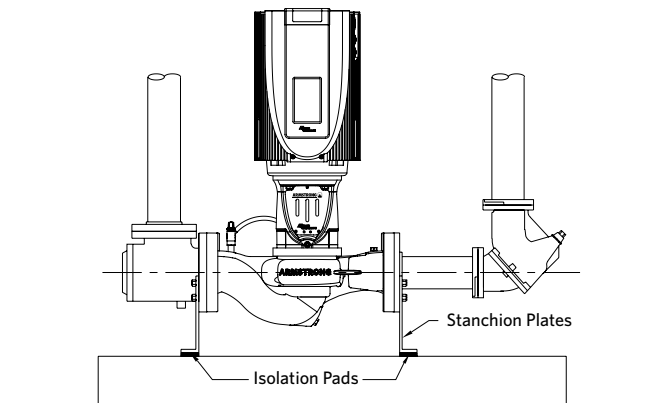

**G SEISMIC REGION INSTALLATION**

FIG. 1.2.7 illustrates installations with stanchion plates for seismically active regions. Seismically rated isolation pads or snubbers with bolts isolated from the stanchion plates are installed to restrain the pump during a seismic event. Pipe hangers carry the weight of the equipment as seismic components are designed only to restrain the equipment during a seismic event.

FIG. 1.2.7

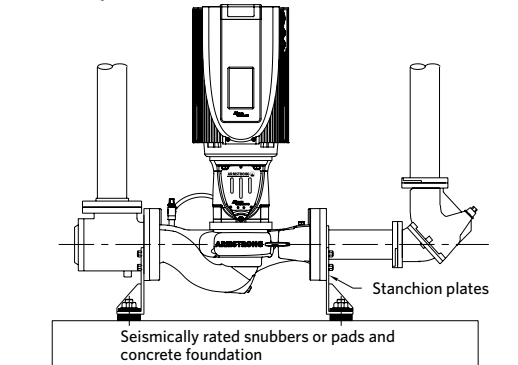

**H MOUNTING IN GROOVED PIPE SYSTEMS**

Many Vertical In-Line pumps are piped successfully into grooved piping systems. In-line pumps are supported well by grooved piping however flange adapter locking devices or a welded flange at the pump should be used to prevent the possibility of pipe mounted pumps rotating in the piping. Armstrong offers grooved suction guides with cast-in outlet flanges and Flo-Trex valves with Armgrip™ fittings to reduce this possibility.

FIG. 1.2.8

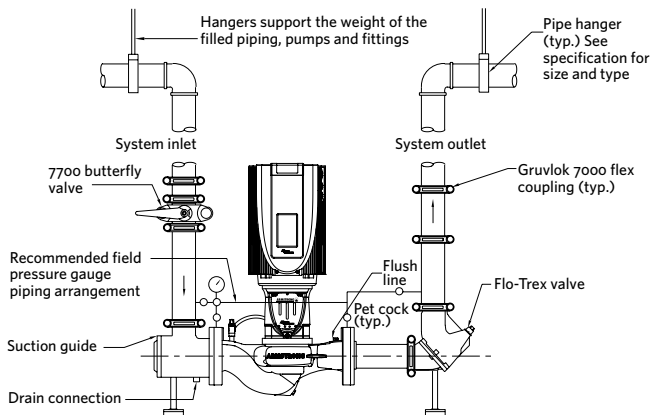

**I MOUNTED ON RIGID BASE WITHOUT FLEXIBLE CONNECTORS**

Connecting the pump to a permanent rigid base (FIG. 1.2.9) is not recommended unless it is isolated from the piping by flexible connectors and the base is isolated from the building structure on an inertia base. (FIG. 1.2.9 is generally acceptable when using plastic piping).

FIG. 1.2.9

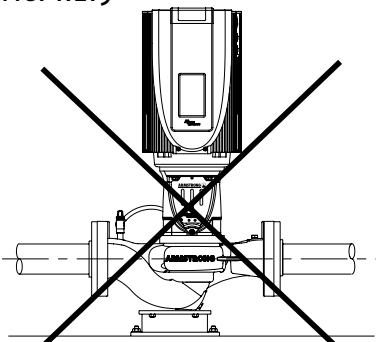

**J HORIZONTAL SHAFT MOUNTING**

Design Envelope pump units with Permanent Magnet motors can be installed in a horizontal shaft orientation.

FIG. 1.2.10

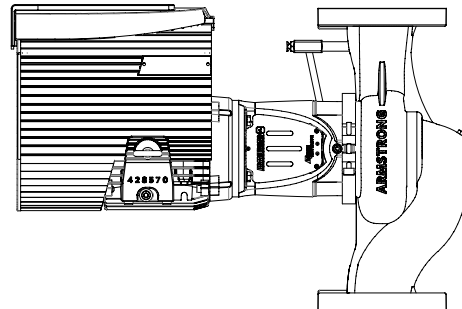

**K**

The motor and integrated control assembly has 2 factory orientations available, each perpendicular to the flow to meet installation spacing requirements.

Where applicable, remove the coupling guard to access the motor bolts. Remove the motor bolts to rotate the motor and integrated control assembly by hand. Care should be taken that the controls are not damaged during lifting and that the flushline, accessories and the coupling guard removal/seal service window are not compromised following the turn (FIG. 1.2.11).

If not convenient for other equipment, motor and controls may be rotated at installation site at 90° increments and the rotating assembly at up to 45° in either direction, provided there are no physical clashes with other equipment. Remove the clamp ring between the casing and adaptor/pedestal and carefully rotate the rotating assembly. Note that the seal flush line may need to be replaced to fit the new orientation.

FIG. 1.2.11

 When reinstalling the clamp, tighten the clamp nut to 90-100 in-lb torque.

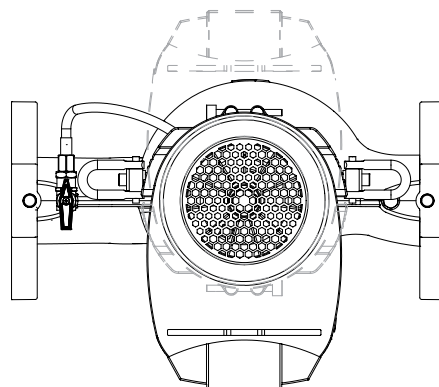

**L CLEARANCE NOTE**

**FIG. 1.2.11**

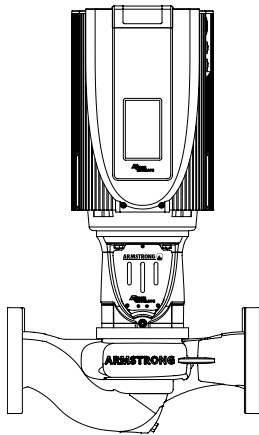

The working clearance in front of the controls should be sufficient for access to service the controls

**IMPORTANT:**

Design Envelope pumps contain a tapped hole in the motor bracket above the discharge flange (see **FIG. 1.2.12**) for draining the well. Pipe this drain hole to a floor drain to avoid overflow of the cavity caused by collecting chilled water condensate or from seal failure.

**M TAPPED COLLECTION WELL ON DESIGN ENVELOPE 4300**

**FIG. 1.2.12**

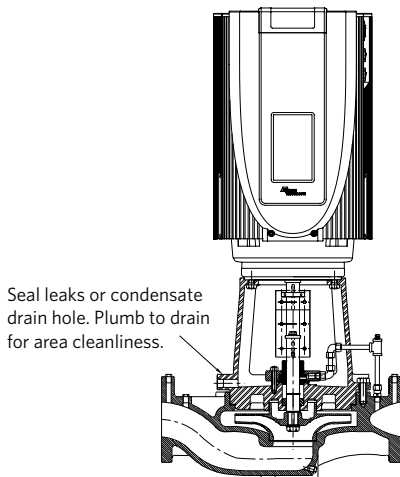

**1.2.3 PUMP PIPING-GENERAL**

Never connect a pump to piping, unless extra care is taken to measure and align the piping flanges well. Always start piping from pump.

Use as few bends as possible and preferably long radius elbows.

Do not use flexible connectors on the suction or discharge of a Vertical In-Line pump, unless the pump is rigidly mounted to a foundation.

Ensure piping exerts no strain on pump as this could distort the casing causing breakage or early failure due to pump misalignment.

All connecting pipe flanges must be square to the pipework and parallel to the pump flanges.

Suction and discharge pipes may be increased or decreased at pump nozzle to suit pump capacity and particular conditions of installation. Use eccentric reducers on suction connection with flat side uppermost.

Layout the suction line with a continual rise towards the pump without high points, thus eliminating possibility of air pockets that may prevent the pump from operating effectively.

A strainer of three or four times the area of the suction pipe, installed in the suction line, will prevent the entrance of foreign materials into the pump. 5 mm (<sup>3</sup>/<sub>16</sub>" ) diameter perforations in the strainer is typical.

In open systems, test suction line for air leaks before starting; this becomes essential with long suction line or static lift.

Install, at the pump suction, a straight pipe of a length equivalent to four or six times its diameter; this becomes essential when handling liquids above 49°C (120°F). Armstrong suction guides may be used in place of the straight pipe run and in-line strainer.

Install an isolation valve in both suction and discharge lines on flooded suction application; these valves are used primarily to isolate the pump for inspection or repair.

Install a non-slam non-return check valve in discharge line between pump and isolation valve to protect pump from excessive back pressure and to prevent water running back through the pump in case of driver failure on open systems.

Armstrong FTV triple function valve may be installed in place of separate check and isolation valves. The FTV valve also includes a throttling feature which **must not** be used to throttle with variable speed pumps operating in variable flow systems, unless the pump is oversized and operating beyond the published pump curve.

**1.2.4 ALIGNMENT**

Design Envelope units are accurately aligned at the factory prior to being shipped and do not need re-aligning when installed. Alignment on a Design Envelope unit may be verified by assuring an equal and parallel gap between coupling halves on both sides of the coupling.

## 2.0 ELECTRICAL SETUP

### 2.1 PRECAUTIONS

#### Safety, risk of death



All electrical connections should be carried out by a qualified and authorised electrician in accordance with local site regulations and the latest issue of the IEE regulations.



For retrofit applications with multiple pumping units operating in parallel, the ampacity of conductors, ratings of switches, branch-circuit, short circuit and ground-fault protection should be reviewed prior to installation (Reference NEC/NFPA 70 section 430, or OESC section 28).



Before removing the system must be disconnected from the mains supply. After switching off, wait for at least 4 minutes for the capacitors to discharge before opening the cover.



Note, all drives have stored charge and all motors will generate some amount of voltage to keep the drive charged while spinning. If power is removed for more than 5 minutes and pump is still spinning, the check valve on the outlet of the pump may be defective, allowing the pump to spin backwards and continue to generate voltage.

#### CAUTION



High voltage testing (Megging) of the motor/inverter may cause damage to the electronic components and therefore should not be carried out.

#### 2.1.1 GROUND LEAKAGE CURRENT



Ground leakage current is primarily caused by the capacitance between motor phases and the motor frame. The Radio Frequency Interference (RFI) filter contributes additional leakage current, as the filter circuit is connected to ground through capacitors.

The size of the leakage current to the ground depends on the following factors, in order of priority:

- 1 Switching frequency
- 2 Motor grounded on site or not

The leakage current is of importance to safety during handling/operation of the Design Envelope pump if (by mistake) the on-board inverter has not been grounded.



Since the leakage current is >3.5mA (approx. 4-20 mA), reinforced Grounding must be established which is required by local wiring standards is to be complied with. Never use ELCB relays that are not suitable for DC fault currents (type A).

If ELCB relays are used, they must be:

- Suitable for protecting equipment with a direct current content (dc) in the fault current (three-phase bridge rectifier)
- Suitable for power-up with short charging current to Ground
- Suitable for a high leakage current

#### 2.1.2 START/STOP OF PUMP

The number of starts/stops via the mains voltage must not exceed one-time per minute.

If a higher number of starts/stops is required, then the start/stop digital input must be used (mains voltage directly connected). This is the preferred method of starting and stopping Design Envelope Pumps.

The three phase mains must be isolated before performing maintenance of the pump.

#### 2.1.3 ADDITIONAL MOTOR PROTECTION



With the exception of supply fuses / MCB's to protect the installation (for over-current and short-circuit protection), no additional overload or over-temperature protection is required (i.e. thermal overloads).

Protection features include:

- Mains phase loss
- Over voltage
- Under voltage
- Electronic thermal motor protection
- Short circuit on motor terminals
- Ground fault on motor terminals
- Over temperature

#### 2.1.4 MOTOR THERMAL PROTECTION AND DERATING

The Design Envelope motors are thermally protected in case limits are exceeded, and additional protection is provided though the drive.

#### A DEPM AMBIENT TEMPERATURE DE-RATING

If the motor is operated at temperatures above 45°C (113°F) (see motor frames below), a derating of the continuous output current (or power) is necessary.

POWER RANGE	DEPM FRAME SIZE	OUTPUT CURRENT AVAILABLE BY % BASED ON AMBIENT TEMPERATURE	
		45°C (113°F)	50°C (122°F)
0 - 3kW	DEPM 90	100%	100%
4kW		100%	90%
5.5kW		100%	80%
0 - 5.5kW	DEPM 112	100%	100%
7.5kW		100%	80%

POWER RANGE	DEPM FRAME SIZE	OUTPUT CURRENT AVAILABLE BY % BASED ON AMBIENT TEMPERATURE	
		45°C (113°F)	50°C (122°F)
0 - 0.5kW	DEPM 71	100%	100%
0.75kW		100%	100%
1.1 - 1.5kW		100%	95%
0 - 1.5kW	DEPM2 90S*	100%	100%
2.2 - 5.5kW	DEPM2 90	100%	95%
0 - 5.5kW	DEPM2 112	100%	95%
7.5kW		100%	95%

\*90s for 575V only

## B EARTH LEAKAGE CURRENT

Earth leakage current is primarily caused by the capacitance between motor phases and the motor frame. The RFI filter contributes additional leakage current, as the filter circuit is connected to earth through capacitors (Cy).

The size of the leakage current to the ground depends on the following factors, in order of priority:

- 1 Switching PWM frequency
- 2 Motor grounded on site or not

The leakage current is of importance to safety during handling/operation of the drive if (by mistake) the drive has not been earthed.

## C OVER VOLTAGE PROTECTION

The voltage in the intermediate circuit is increased when the motor acts as a generator. This occurs in two cases:

- 1 The load generates energy.
- 2 During deceleration (**ramp-down**) if the moment of inertia is high, the load is low and the ramp-down time is too short for the energy to be dissipated as a loss in the motor frequency converter, the motor and the installation.

The drive turns off to protect the IGBT transistors and the intermediate circuit capacitors when a certain voltage level is reached on DCbus.

## D MAINS SUPPLY INTERFERENCE/HARMONICS

A motor integral drive takes up a non-sinusoidal current from mains. A non-sinusoidal current can be transformed by means of a Fourier analysis and split up into sine wave currents with different frequencies, i.e. different harmonic currents IN with 50 Hz as the basic frequency.

Some of the harmonic currents might disturb communication equipment connected to the same transformer or cause resonance in connection with power-factor correction batteries.

To ensure low, harmonic currents, for the residential and commercial environments, an optional harmonic filter is necessary.

## 2.2 ELECTRICAL SPECIFICATION

### 2.2.1 DEPM

Main supply (L1 L2 L3)	
Supply frequency	48 - 62Hz
Supply voltage	3 × 200-230V ± 10%, 3 × 380-480V ± 10%, 3 × 575-600V ± 10%
Max. imbalance of supply voltage	2% of rated supply
Switching on supply voltage	15/ hr (Minimum 4m Interval)

### Output ratings

Output Current	100% Drive Rated Power continuously
Overload Capacity	106% of rated power

### Digital inputs

Programmable digital inputs	2
Voltage level	0-24Vdc (user selectable NPN or PNP)

### Analog input

Programmable Analog Inputs	2
Voltage Input Mode	0:10Vdc
Voltage Mode Max Voltage	24Vdc
Voltage Mode Input Resistance	10KΩ
Current Input Mode	4:20mA
Current Mode Max Current	20mA
Current Mode Max Voltage	24Vdc
Current Mode Input Resistance	500Ω
Resolution	12-bit

### Analog output

Analog output	1
Output Mode	Current, 4:20mA (the total resistance of the the load across this output shall be 500Ω)
Maximum Current	20mA
Resolution	12-bit

<b>Digital output</b>	
Digital Output	2
Output Range	0-24Vdc (NPN)
Maximum Current	30mA

<b>Relay output</b>	
Relay output	2 (N.O. N.C. COM)
Max terminal load	5A @ 30Vac 5A @ 250Vac

<b>Externals</b>	
Enclosure	IP55 OR IP66
Vibration test	IEC 60068-2-6
Max relative humidity	95% (Non-condensing)
Operating ambient temperature	-10:45°C
Storage ambient	-25°C:60°C
Min. ambient temperature at full operation	-10°C
Altitude	1000m without derating, de-rate 1% per 100m above 1000m
Maximum Altitude	3000m

<b>Compliance with Standards</b>	
EN 61800-3:2004	Adjustable speed electrical power drive systems. EMC requirements
IEC 61800-5-1	Adjustable speed electrical drive systems - part 5-1: safety requirements - electrical, thermal and energy
EN 60204-1	Safety of machinery - electrical EMC equipment of machines-part 1: general rules

### 2.2.2 FRAME 71

<b>Main supply (L1 L2 L3)</b>	
Supply frequency	48 - 62Hz
Supply voltage	1 × 200-240V ± 10%, 3 × 200-230V ± 10%, 3 × 380-480V ± 10%
Max. imbalance of supply voltage	2% of rated supply
Switching on supply voltage	30/ hr (Minimum 2 min Interval)

<b>Output ratings</b>	
Output Current	100% Drive Rated Power continuously
Overload Capacity	106% of rated power

<b>Digital inputs</b>	
Programmable digital inputs	2
Voltage level	0-24Vdc (user selectable NPN or PNP)

<b>Analog input</b>	
Programmable Analog Inputs	2
Voltage Input Mode	0:10Vdc
Voltage Mode Max Voltage	24Vdc
Voltage Mode Input Resistance	240KΩ
Current Input Mode	4:20mA
Current Mode Max Current	20mA
Current Mode Max Voltage	5Vdc
Current Mode Input Resistance	180Ω
Resolution	12-bit

<b>Analog output</b>	
Analog output	1
Output Mode	Current, 4:20mA
Maximum Current	20mA
Current Mode Max Voltage	24Vdc
Current Mode Load Resistance	< 1 kΩ
Resolution	12-bit

<b>Digital output</b>	
Digital Output	2
Output Range	0-24Vdc (PNP)
Maximum Current	20mA

<b>Relay output</b>	
Relay output	2 (N.O. N.C. COM)
Max terminal load	5A @ 30Vac 5A @ 250Vac

### Externals

Enclosure	IP55 OR IP66
Vibration test	IEC 60068-2-6
Max relative humidity	95% (Non-condensing)
Operating ambient temperature	-10:40°C
Storage ambient	-25:60°C
Min. ambient temperature at full operation	-10°C
Altitude	1000m without derating, de-rate 1% per 100m above 1000m
Maximum Altitude	3000m

### Compliance with Standards

EN 61800-3:2004	Adjustable speed electrical power drive systems. EMC requirements
IEC 61800-5-1	Adjustable speed electrical drive systems - part 5-1: safety requirements - electrical, thermal and energy
EN 60204-1	Safety of machinery - electrical emc equipment of machines-part 1: general rules
UL 61800-5-1	Adjustable speed electrical power drive systems - part 5-1: safety requirements - electrical, thermal and energy
CSA C22.2#274	Adjustable speed drives

### 2.2.3 DEPM 2

#### Main supply (L1 L2 L3)

Supply frequency	48 - 62Hz
Supply voltage	3 × 200-230v ± 10%, 3 × 380-480v ± 10%, 3 × 575-600v ± 10%
Max. imbalance of supply voltage	3% of rated supply
Switching on supply voltage	120/ hr (Minimum 30s Interval)

#### Output ratings

Output Current	100% Drive Rated Power continuously
Overload Capacity	106% of rated power

#### Digital inputs

Programmable digital inputs	2
Voltage level	0-24Vdc (NPN)

### Analog input

Programmable Analog Inputs	2
Voltage Input Mode	0:10Vdc
Voltage Mode Max Voltage	30Vdc
Current Input Mode	4:20mA
Current Mode Max Current	20mA
Resolution	12-bit

### Analog output

Analog output	1
Output Mode	Current, 4:20mA
Maximum Current	20mA
Resolution	10-bit

### Digital output

Digital Output	1
Output Range	0-24Vdc (PNP)
Maximum Current	20mA

### Relay output

Relay output	2 (1×N.O. and 1×C.O.)
Max terminal load	5A @ 30Vac 5A @ 250Vac
Optional relay output	3×N.O.
Max terminal load	5A @ 30Vac 6A @ 250Vac

### Externals

Enclosure	IP55 OR IP66
Vibration test	IEC 60068-2-6
Max relative humidity	95% (Non-condensing)
Operating ambient temperature	-10:45°C
Storage ambient	-40:60°C
Min. ambient temperature at full operation	-10°C
Altitude	1000m without derating, de-rate 1% per 100m above 1000m
Maximum Altitude	4000m



---

**Compliance with Standards**

---

EN 61800-5-1: 2007:A11:2021	Adjustable speed electrical power drive systems. Safety requirements. Electrical, thermal and energy.
EN 61800-3:2018	Adjustable speed electrical power drive systems. EMC requirements and specific test methods.
EN 60204-1:2018	Safety of machinery. Electrical equipment of machines general requirements. Uncontrolled stop "Category 0"
UL 61800-5-1	Adjustable speed electrical power drive systems - part 5-1: safety requirements - electrical, thermal and energy
CSA C22.2#274	Adjustable speed drives

## 2.3 ELECTRICAL INSTALLATION

### 2.3.1 POWER WIRING

#### 2.3.1.1 POWER WIRING FOR FRAME 71 MOTORS - 1 PHASE

Upper right corner of the motor. Use Access port #1 for power wiring and ground.

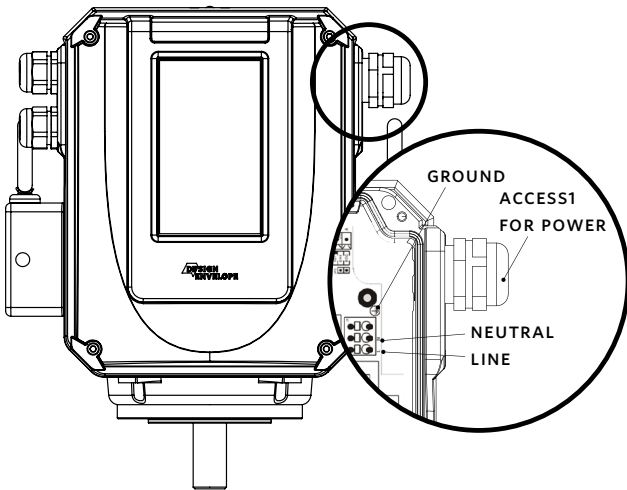

#### 2.3.1.2 POWER WIRING FOR FRAME 71 MOTORS - 3 PHASE

Upper right corner of the motor. Use Access port #1 for power wiring and ground.

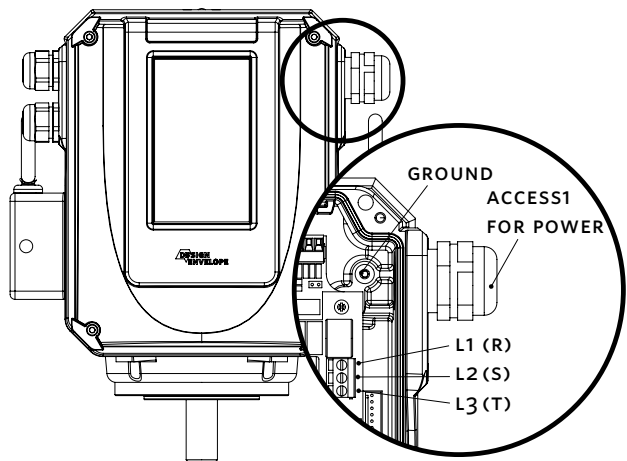

#### 2.3.1.3 POWER WIRING FOR DEPM MOTORS

Upper right corner of the motor. Use Access port #1 for power wiring and ground.

PIN1	L1	L1 power supply
PIN2	L2	L2 power supply
PIN3	L3	L3 power supply

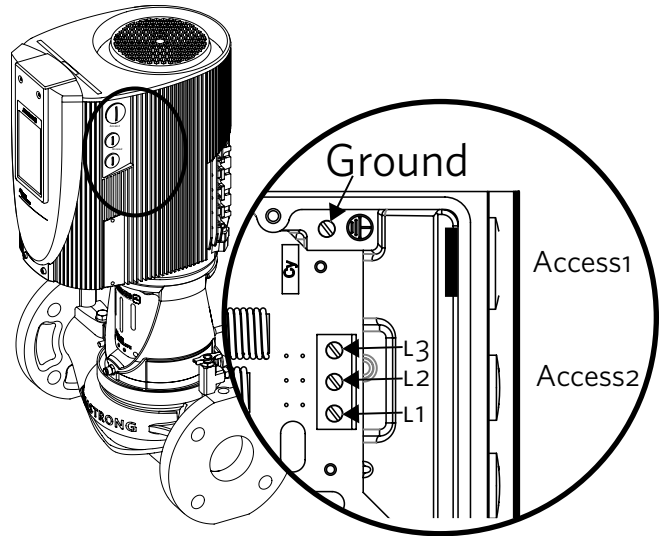

#### 2.3.1.4 POWER WIRING FOR DEPM 2 MOTORS

Upper right corner of the motor. Use Access port #1 for power wiring and ground.

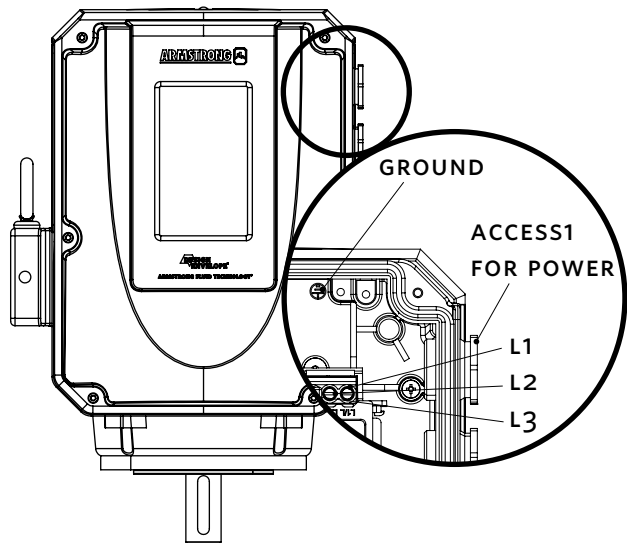

### 2.3.2 TOOLS YOU WILL NEED

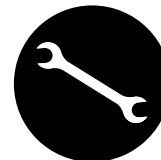

### 2.3.3 THE MAIN COVER DISASSEMBLY

#### 2.3.3.1 MAIN COVER DISASSEMBLY - FRAME 71 MOTORS

1

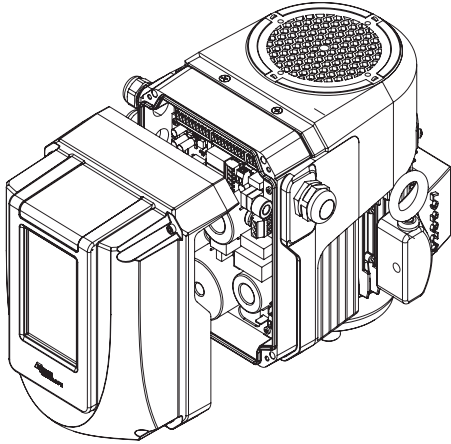

2

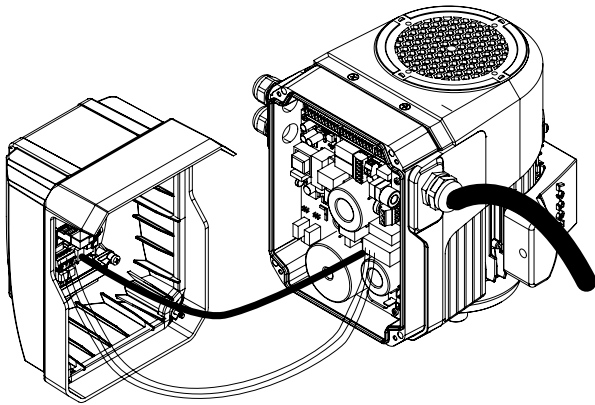

3

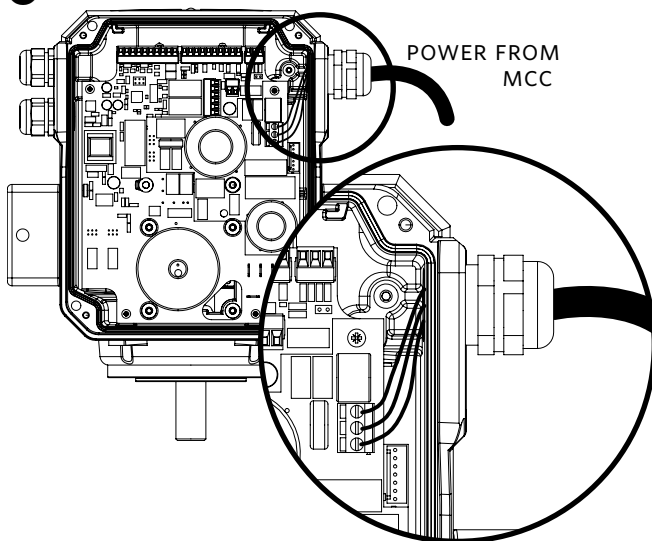

4

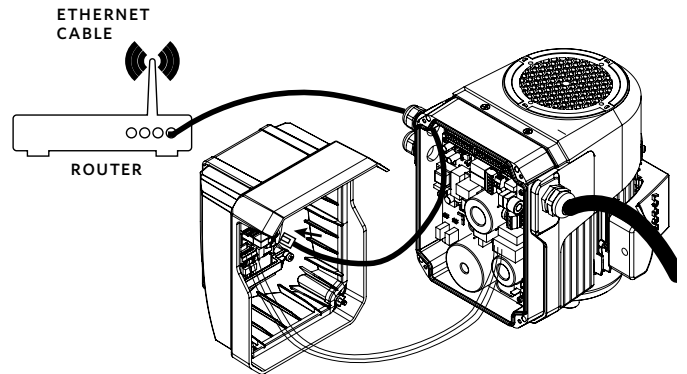

#### 2.3.3.2 THE MAIN COVER DISASSEMBLY- DEPM MOTORS

##### WARNING



Before removing the system must be disconnected from the mains supply. After switching off, wait for at least 4 minutes for the capacitors to discharge before opening the cover.

1

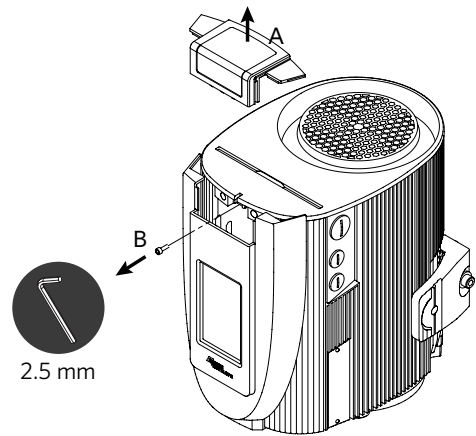

2

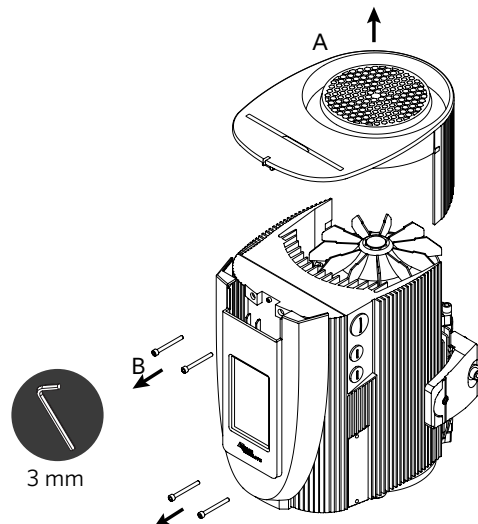

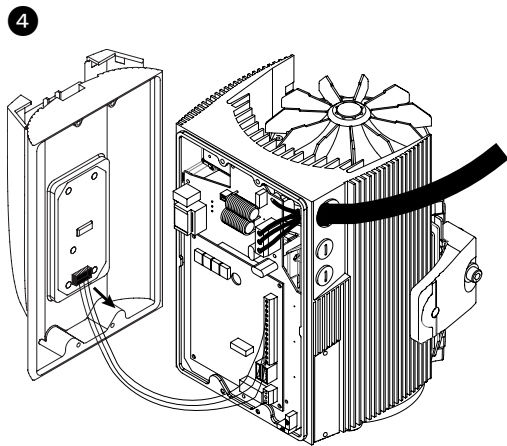
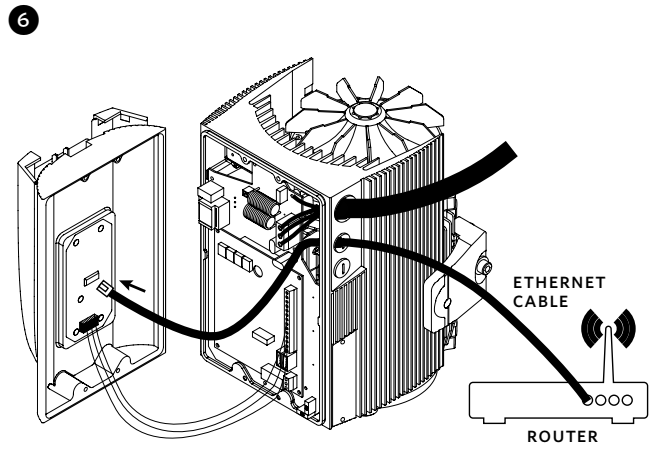
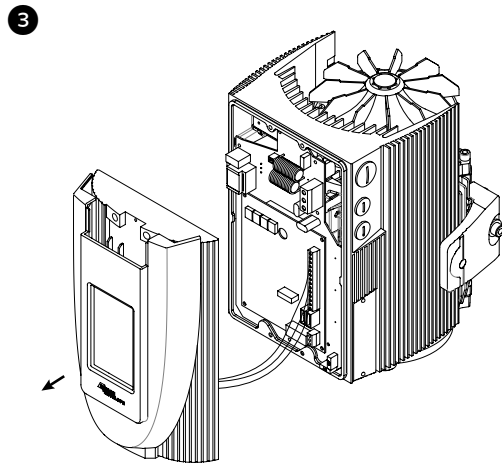

### 2.3.3.3 THE MAIN COVER DISASSEMBLY-DEPM2 MOTORS

#### CAUTION



When you remove the front cover, pay attention to the wiring connection of the control board, unplug the connection and remove completely the cover.

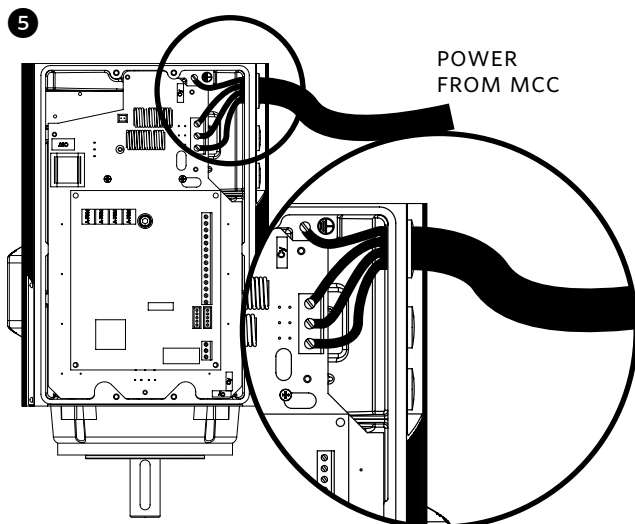
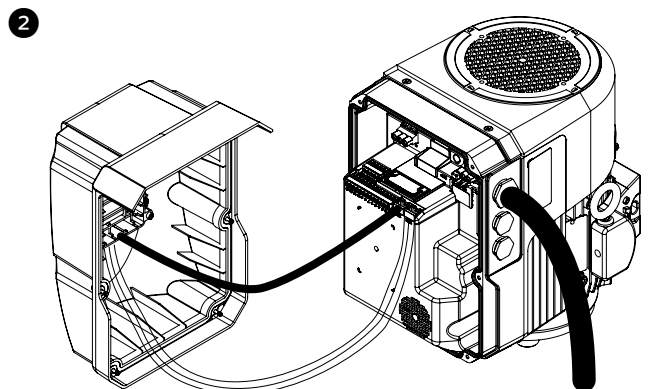
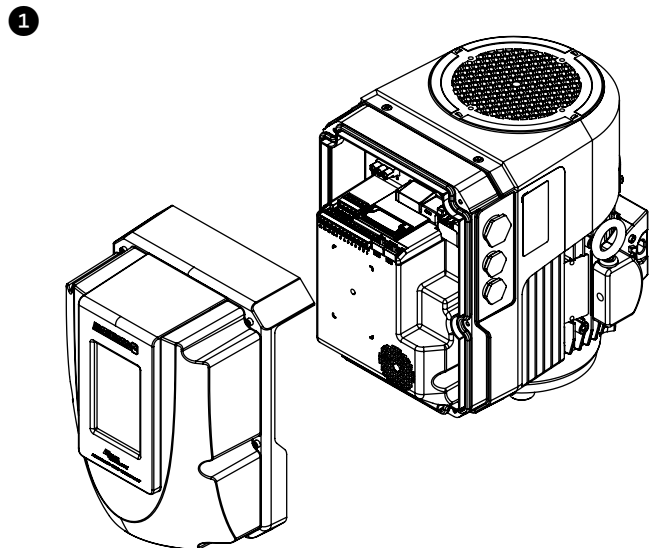

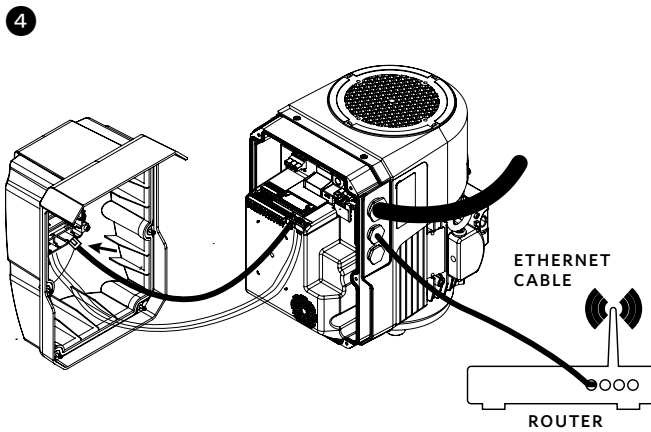
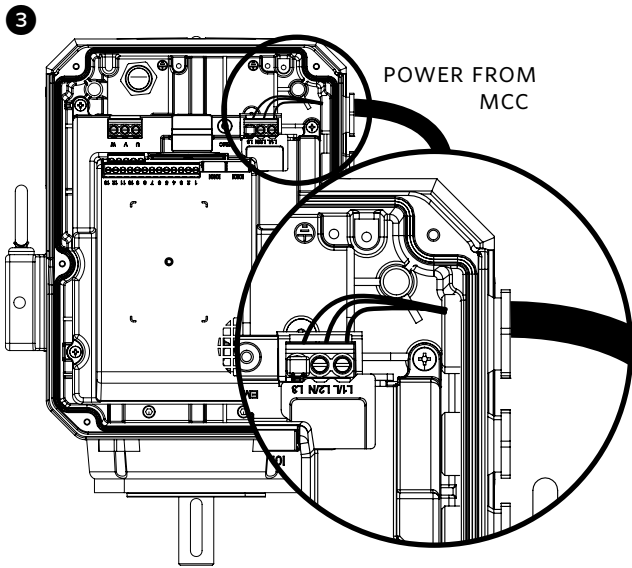

### 2.3.4 CONTROL TERMINAL WIRING

#### 2.3.4.1 CONTROL TERMINAL WIRING FOR FRAME 71 MOTORS

FIG 2.3.2.A Motor Control Board

##### MODBUS CONNECTOR (J15)

Pin 1	485-A
Pin 2	485-B
Pin 3	GND ISOLATED

##### RELAYS CONNECTOR (J12)

Pin 1	Relay 1 NO
Pin 2	Relay 1 COM
Pin 3	Relay 1 NC
Pin 4	Relay 2 NO
Pin 5	Relay 2 COM
Pin 6	Relay 2 NC

##### I/O CONNECTOR (J16-J18)

Pin 1	+24 ISOLATED OUTPUT (200mA)
Pin 2	GND ISOLATED
Pin 3	+10V ISOLATED / Analog Output 4-20mA (+)
Pin 4	Analog Output 4-20mA (-)
Pin 5	Analog Output 0-10V
Pin 6	GND ISOLATED
Pin 7	+24 ISOLATED
Pin 8	Digital Input 1
Pin 9	Digital Input 2
Pin 10	Comm NPN / PNP (jumper)
Pin 11	GND ISOLATED
Pin 12	Digital Output 1 (open collector 20mA)
Pin 13	+24 ISOLATED
Pin 14	Digital Output 2 (open collector 20mA)
Pin 15	Analog Input 1, 4-20mA (+)
Pin 16	Analog Input 1, 0-10V
Pin 17	+10V ISOLATED
Pin 18	GND ISOLATED
Pin 19	Analog Input 2, 4-20mA (+)
Pin 20	Analog Input 2, 0-10V

2.3.4.2 CONTROL TERMINAL WIRING FOR DEPM MOTORS

FIG 2.3.2.B Motor Control Board

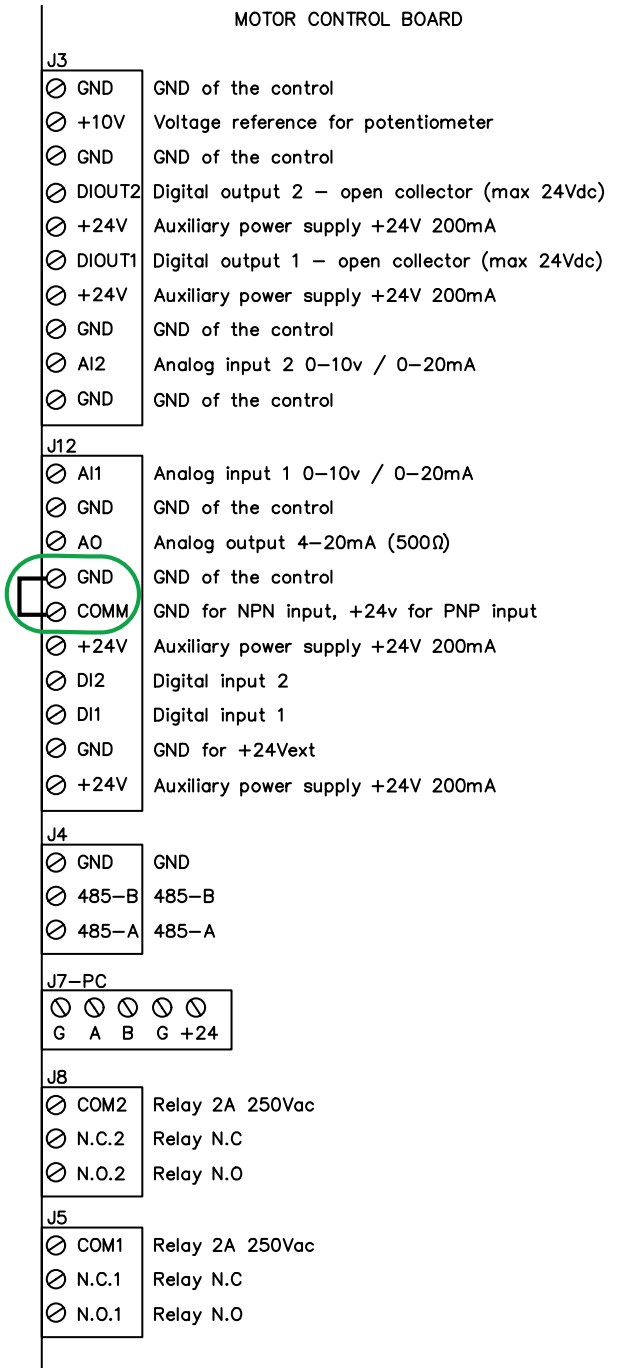

2.3.4.3 CONTROL TERMINAL WIRING FOR DEPM2 MOTORS

FIG 2.3.2.C Motor Control Board

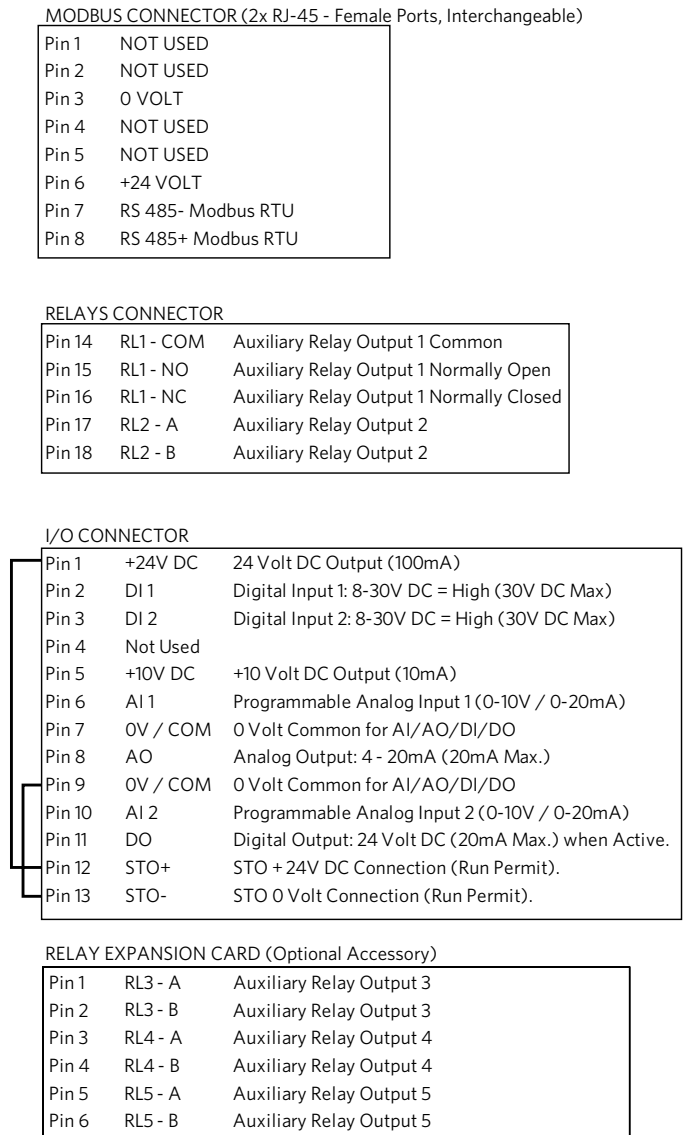

### 2.3.5 ANALOG / DIGITAL INPUTS

#### 2.3.5.1 ANALOG / DIGITAL INPUTS FOR FRAME 71 MOTORS

I/O CONNECTOR (J16-J18)

Pin 1	+24 ISOLATED OUTPUT (200mA)
Pin 2	GND ISOLATED
Pin 3	+10V ISOLATED / Analog Output 4-20mA (+)
Pin 4	Analog Output 4-20mA (-)
Pin 5	Analog Output 0-10V
Pin 6	GND ISOLATED
<b>Digital Input Wiring</b>	
Pin 7	+24 ISOLATED
Pin 8	Digital Input 1
Pin 9	Digital Input 2
Pin 10	Comm NPN / PNP (jumper)
Pin 11	GND ISOLATED
<b>Analog Input Wiring</b>	
Pin 12	Digital Output 1 (open collector 20mA)
Pin 13	+24 ISOLATED
Pin 14	Digital Output 2 (open collector 20mA)
Pin 15	Analog Input 1, 4-20mA (+)
Pin 16	Analog Input 1, 0-10V
Pin 17	+10V ISOLATED
Pin 18	GND ISOLATED
Pin 19	Analog Input 2, 4-20mA (+)
Pin 20	Analog Input 2, 0-10V

#### I WIRING DIGITAL INPUTS FOR FRAME 71 MOTORS

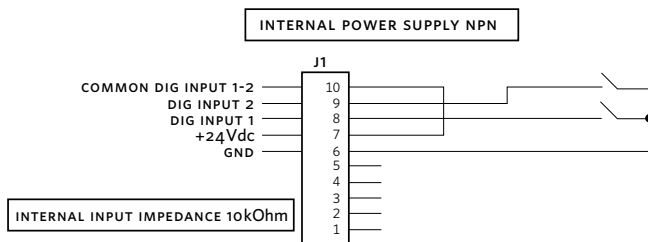

Recommended, internal NPN is default factory setting

Optional, external power supply NPN

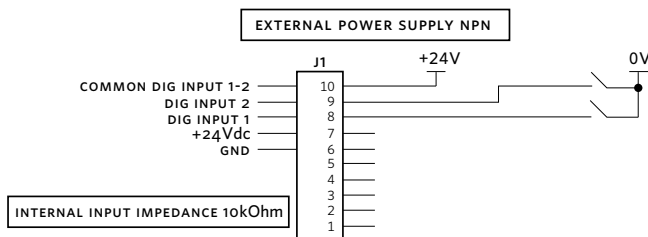

#### II WIRING ANALOG INPUTS FOR FRAME 71 MOTORS

##### 0-10V INPUTS

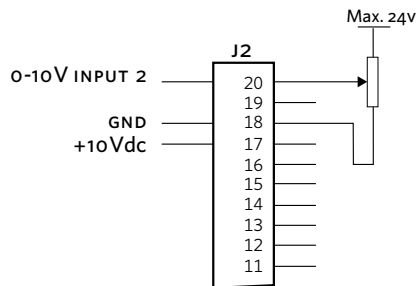
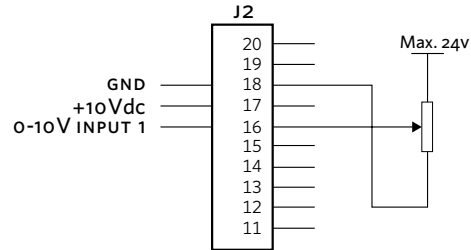

##### 0-20mA INPUTS

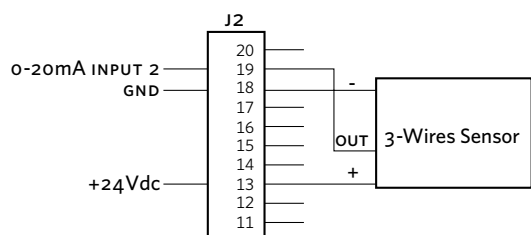
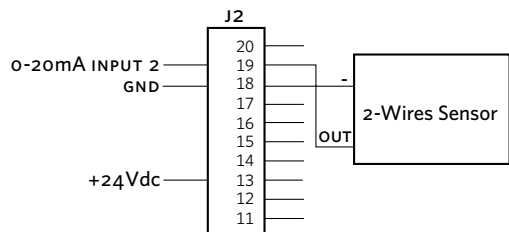
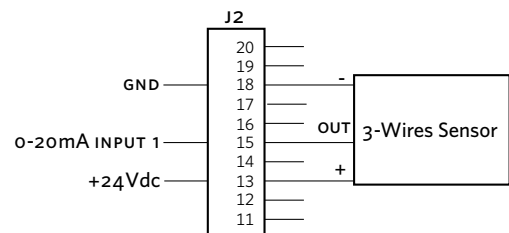
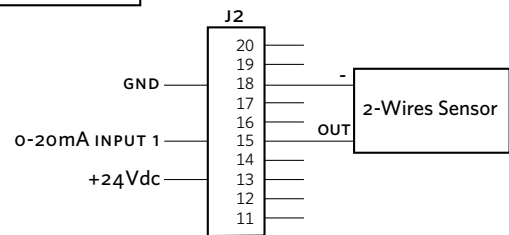

**2.3.5.2 ANALOG / DIGITAL INPUTS FOR DEPM MOTORS**

**A WIRING**

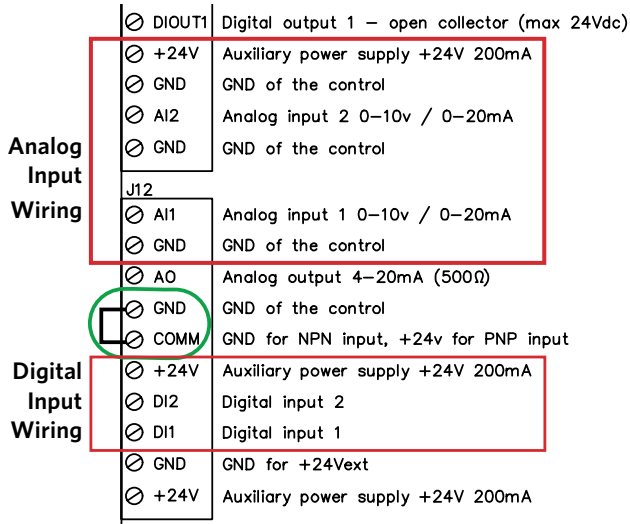

**2.3.5.3 ANALOG / DIGITAL INPUTS FOR DEPM2 MOTORS**

**FIG 2.3.5.3 - Wiring Diagram for DEPM2 Motor Inputs and Outputs**

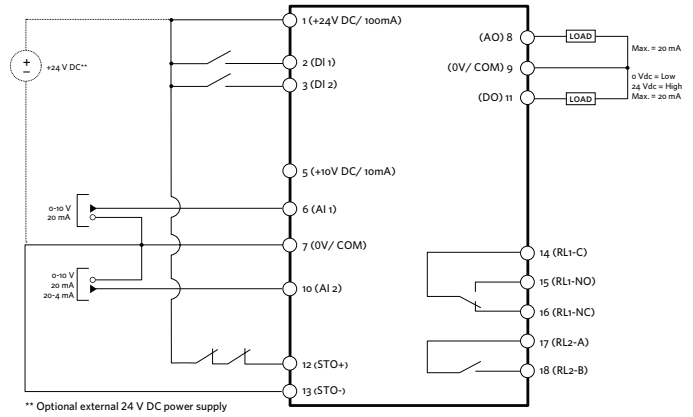

The number of starts/stops via the mains voltage must not exceed one-time per minute.

If a higher number of starts/stops is required then the start/stop digital input must be used (mains voltage directly connected). This is the preferred method of starting and stopping Design Envelope Pumps.



**The three phase mains must be isolated before performing maintenance of the pump.**

**Personnel requirements**

- 1 Armstrong Tier 3 training or equivalent
- 2 Ability to terminate simple control wiring
- 3 Ability to configure Armstrong controls
- 4 All work will be done on low voltage, however, when removing the controller cover high voltage may be exposed. An electrician license is required in some areas

**I WIRING DIGITAL INPUTS**

- 1 Connect one port of the contact to DIGIN1 or DIGIN2.
- 2 Connect the other port to +24VEXT

**II WIRING ANALOG INPUTS**

- 1 Connect signal source to ANIN1 Or ANIN2
- 2 Connect the other port to GND

**2.3.6 ANALOG / DIGITAL OUTPUT**

**2.3.6.1 ANALOG OUTPUT FOR FRAME 71 MOTORS**

**FIG 2.3.6.1**

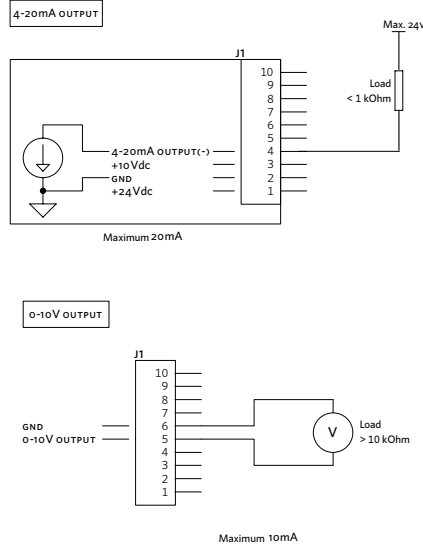

SOURCE VOLTAGE (VDC)	MAXIMUM LOAD RESISTANCE (OHM)
5	150
10	400
24	1000



**2.3.6.2 DIGITAL OUTPUT FOR FRAME 71 MOTORS**

**FIG 2.3.6.2**

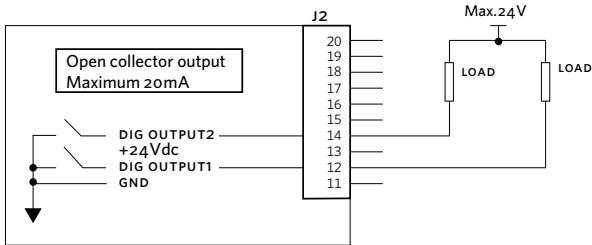

**2.3.6.3 ANALOG OUTPUT FOR DEPM MOTORS**

**FIG 2.3.6.3**

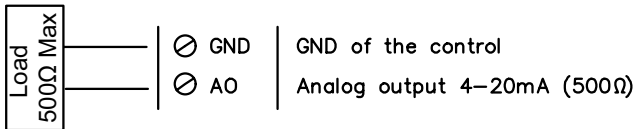

**2.3.6.4 DIGITAL OUTPUT FOR DEPM MOTORS**

If either of the digital outputs are to be used for voltage differential, a 500 ohm resistor (supplied by others) must be connected between the respective digital output and the 24VEXT terminal. Refer to **FIG 2.3.6.4**

**FIG 2.3.6.4**

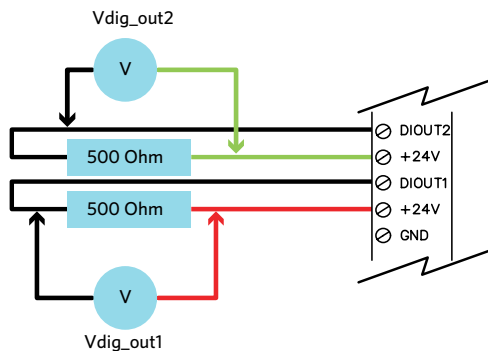

**2.3.6.5 ANALOG OUTPUT FOR DEPM2 MOTORS**

Refer to **FIG 2.3.5.3** - Wiring Diagram for DEPM2 Motor Inputs and Outputs

**2.3.6.6 DIGITAL OUTPUT FOR DEPM2 MOTORS**

Refer to **FIG 2.3.5.3** - Wiring Diagram for DEPM2 Motor Inputs and Outputs

**2.3.7 RELAY OUTPUT**

**2.3.7.1 RELAY OUTPUT FOR FRAME 71 MOTORS**

Relay Connector(J12)

PIN 1	Relay 1 N.O.
PIN 2	Relay 1 COM
PIN 3	Relay 1 N.C.
PIN 4	Relay 2 N.O.
PIN 5	Relay 2 COM
PIN 6	Relay 2 N.C.

**2.3.7.2 RELAY OUTPUT FOR DEPM MOTORS**

J5 & J8 for Relay output

<b>J8</b> Run	N.O. 2	Relay N.O.
	N.C. 2	Relay N.C.
	COM2	Relay 2A 250VAC
<b>J5</b> Alarm	N.O. 1	Relay N.O.
	N.C. 1	Relay N.C.
	COM 1	Relay 2A 250VAC

**2.3.7.3 RELAY OUTPUT FOR DEPM2 MOTORS**

PIN 14	Relay 1 COM
PIN 15	Relay 1 N.O.
PIN 16	Relay 1 N.C.
PIN 17	Relay 2 A
PIN 18	Relay 2 B

Max. Relay switching voltage: 250V AC/ 30V DC  
Max. Relay switching current: 6A(250V AC)/5A(30V DC)  
Environmental: -10°C .... +50°C  
Terminal Torque: 0.5Nm (4.5 lb-in)

**2.3.8 SUPPLY VOLTAGE**

The supply voltage details can be found on the 4300 & 4380 nameplate. Please ensure that the unit is suitable for the electrical supply on which it is to be used. The mains supply for Design Envelope pumps is as follows:

- 1 × 200-230V ± 10%,
- 3 × 200-230V ± 10%,
- 3 × 380-480V ± 10%,
- 3 × 575-600V ± 10%

**Frequency** - 50/60Hz

### 2.3.9 SUPPLY FUSING

#### Branch circuit protection

In order to protect the installation against electrical and fire hazard, all branch circuits in an installation, switch gear, machines etc., must be short-circuit and over-current protected according to the national/international regulations. Please refer to **SECTION 8.0** (Fuse and wire recommendation).

#### Short circuit protection

The inverter must be protected against short-circuit to avoid electrical or fire hazard. The frequency converter provides full short circuit protection in case of a short-circuit on the motor output.

## 2.4 DESIGN ENVELOPE PUMP CONTROLLER WIRING

FIG 2.4 Controller Board (DEPC)

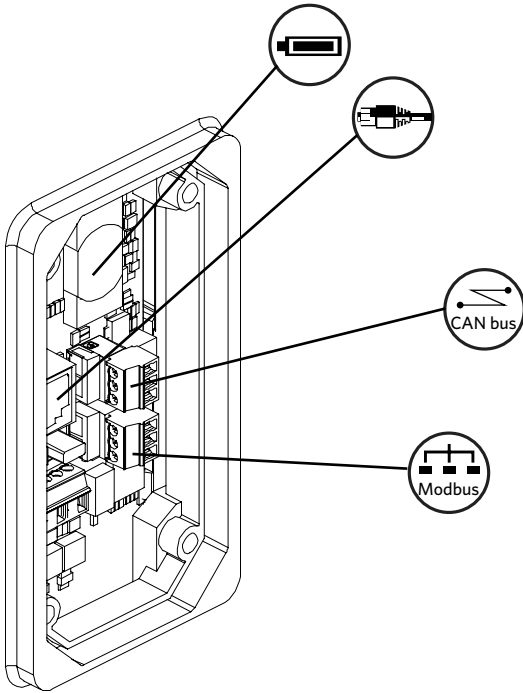
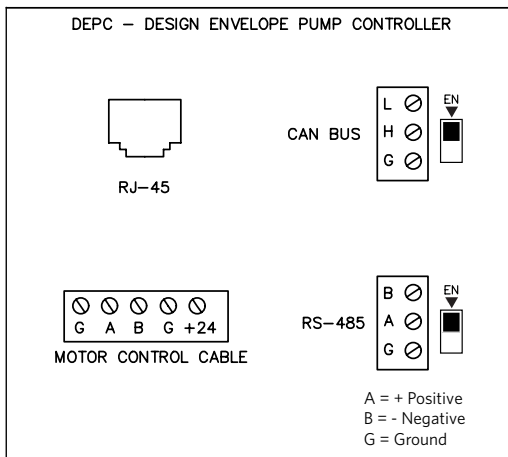

FIG 2.4A



### 2.4.1 BATTERY

The battery is used to power the real-time clock whenever the pump is disconnected from mains power. It is recommended the battery be changed every 2 to 3 years.

### 2.4.2 ETHERNET CONNECTIVITY

For a BACnet IP or Modbus TCP connection to a building automation system (BAS), connect the network cable to the RJ-45 port, as shown in FIG. 2.4A.

### 2.4.3 CAN BUS WIRING

The CAN bus port on the DEPC has terminals for the following signal connections: High, Low, and Ground, as shown in FIG. 2.4A. If multiple pumps are connected in parallel for CAN bus (supplied by others) they should be daisy chained together. Ensure that only the first and last terminating resistor switches are set to Enabled.

### 2.4.4 RS 485 WIRING

For a BACnet MS/TP or Modbus RTU connection to a building automation system, connect the network cable to the RS-485 port, as shown in FIG. 2.4A. When the DEPC is at the end of the RS-485 network, ensure that the terminating resistor is Enabled by setting the corresponding switch to the EN position.

If multiple pumps are connected to the BAS, ensure that only the first and last terminating resistor switches are set to Enabled. See example below in FIG 2.4.1

FIG 2.4.1

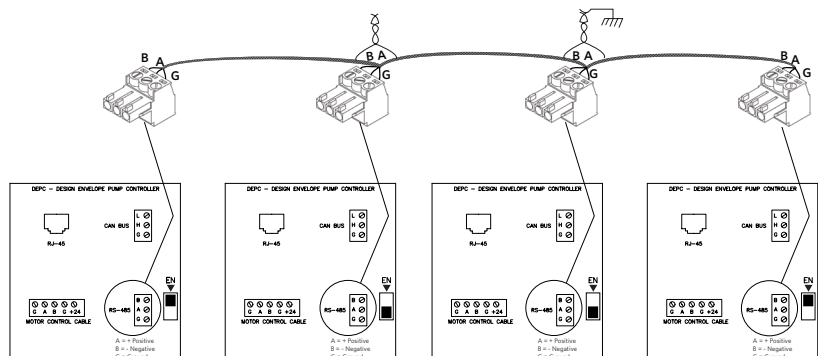

### 2.4.5 NETWORKING OPTIONS

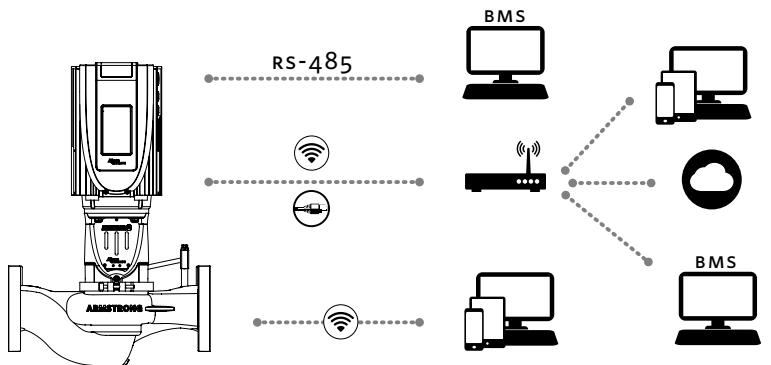

### 3.0 NETWORKING CONTROLS

When connecting to a building automation system (BAS), the pump needs to be properly configured for the network.

For a BACnet IP or Modbus TCP connection, connect the network cable to the RJ-45 port, as shown in **FIG. 2.4**.

For a BACnet MS/TP or Modbus RTU connection, connect the network cable to the RS-485 ("Modbus") port, as shown in **FIG. 2.4**.

The BAS settings can be configured through either the LCD, or Web Interface.

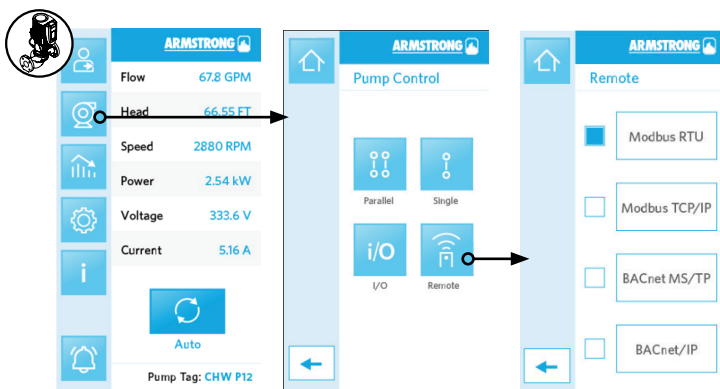

For BACnet MS/TP or TCP/IP: Enter the BACnet address, baud rate, and unique device instance number (as applicable)

For Modbus RTU or TCP/IP: Enter the Modbus address, baud rate, and parity stop bits (as applicable)

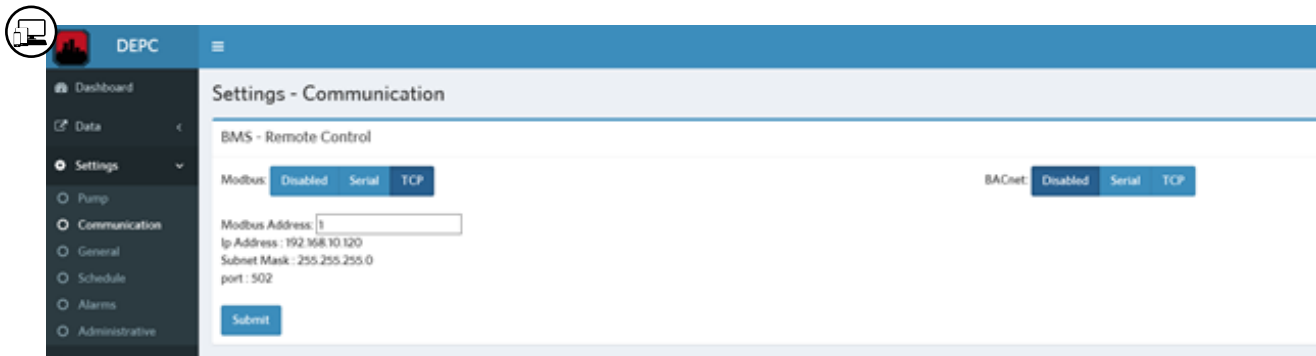

### 3.1 MODBUS REGISTER MAP - VERSION 1 - FOR FIRMWARE V1.16 AND OLDER

FUNCTION CODE		START ADDRESS	MODBUS REGISTER	DESCRIPTION	# OF REGISTERS	CHANGE DURING OPERATION	DATA TYPE	UNIT	NOTES
READ	WRITE								
0x03	0x06								
<b>Status</b>									
x		100	101	Actual Speed	1	N/A	UINT16	1 RPM	The current speed of the vFD in RPM.
x		101	102	Actual Speed	1	N/A	UINT16	0.1 %	The current speed of the vFD in % of the nominal motor speed.
x		102	103	Motor Power	2	N/A	UINT32	0.01	Units as configured on Pump Control Module.
x		104	105	Motor Input Voltage	1	N/A	UINT16	0.1 V	Voltage delivered by the vsd to the motor.
x		105	106	Motor Input Current	2	N/A	UINT32	0.01 A	Current delivered by the vsd to the motor.
x		107	108	Sensorless Head	2	N/A	UINT32	0.01	Units as configured on Pump Control Module.
x		109	110	Sensorless Flow	2	N/A	UINT32	0.01	Units as configured on Pump Control Module.
x		111	112	Total Flow	2	N/A	UINT32	0.01	Used for Parallel sensorless mode
x		113	114	Total Power	2	N/A	UINT32	0.01	Used for Parallel sensorless mode
x		115	116	Number of Running Pumps	1	N/A	UINT16	-	Used for Parallel sensorless mode
x		116	117	Max Sensorless Flow	2	N/A	UINT32	0.01	Units as configured on Pump Control Module.
x		118	119	Max Sensorless Head	2	N/A	UINT32	0.01	Units as configured on Pump Control Module.
x		122	123	Status	1	N/A	UINT16	-	Bit: 0 = pump run status (0=not rotating, 1=rotating)
<b>I/O</b>									
x		200	201	Digital In	1	N/A	UINT16	-	Digital input 1 is bit 0 and input 2 is bit 1.
x		201	202	Analog In 1	2	N/A	UINT32	0.01 V, 0.01 mA	Units as configured on Pump Control Module
x		203	204	Analog In 2	2	N/A	UINT32	0.01 V, 0.01 mA	Units as configured on Pump Control Module
x		205	206	Analog Out 1	1	N/A	UINT16	0.01 mA	
x		206	207	Digital Out	1	N/A	UINT16	-	Digital output 1 is bit 0 and output 2 is bit 1.
x		207	208	Relays	1	N/A	UINT16	-	Relay 1 is bit 0 and relay 2 is bit 1.
<b>Units</b>									
x		250	251	Flow Units	1	N/A	UINT16	-	1 = l/s; 2 = m <sup>3</sup> /h; 3 = g/m
x		251	252	Pressure Units	1	N/A	UINT16	-	1 = bar; 2 = kPa; 3 = psi; 4 = ft; 5 = m
x		252	253	Power Units	1	N/A	UINT16	-	1 = kw; 2 = hp
x		253	254	Speed Units	1	N/A	UINT16	-	1 = RPM; 2 = %
x		254	255	Temperature Units	1	N/A	UINT16	-	1 = Degrees Celsius; 2 = Degrees Fahrenheit
<b>Counters</b>									
x		275	276	Total Pump Running Hours	2	N/A	UINT32	1 h	
x	x	277	278	Trip Pump Running Hours	2	N/A	UINT32	1 h	Writing 0 to this register resets the counter.
x		279	280	Total Controller Running Hours	2	N/A	UINT32	1 h	
x		281	282	Present Controller Running Hours	2	N/A	UINT32	1 h	The running hours since the controller was powered on.
x		283	284	Total Pump Running kWh Counter	2	N/A	UINT32	1 kWh	
x	x	285	286	Trip Pump Running kWh Counter	2	N/A	UINT32	1 kWh	Writing 0 to this register rests the counter.

FUNCTION CODE		START ADDRESS	MODBUS REGISTER	DESCRIPTION	# OF REGISTERS	CHANGE DURING OPERATION	DATA TYPE	UNIT	NOTES
READ	WRITE								
0x03	0x06								
<b>Control Settings</b>									
x		300	301	Control Mode	1	Yes	UINT16	-	1 = Parallel; 2 = Inputs; 3 = Remote; 4 = Constant Flow; 5 = Constant Pressure; 6 = Linear Pressure; 7 = Quadratic Pressure; 8 = Quad Pressure Maximum; 9 = Quad Pressure Minimum; 10 = Quadratic Pressure Max/Min
x	x	301	302	HOA State	1	Yes	UINT16	-	0 = Off; 1 = Hand; 2 = Auto
x	x	302	303	Active Parameters	1	Yes	UINT16	-	1 = standard; 2 = mode 1 (heating mode); 3 = mode 2 (cooling mode)
x	x	303	304	Minimum Speed Limit	1	Yes	UINT16	0.1	In RPM
x	x	304	305	Maximum Speed Limit	1	Yes	UINT16	1	In RPM.
x	x	305	306	Hand Mode Speed	1	Yes	UINT16	0.1	Units as configured on Pump Control Module.
x	x	306	307	BMS Set Speed	1	Yes	UINT16	0.1	Units as configured on Pump Control Module.
<b>Alarms and Warnings</b>									
x		400	401	Alarms	2	N/A	UINT32	-	Refer to Alarms Table for Bit Positions
x		402	403	Warnings	2	N/A	UINT32	-	Refer to warnings table for Bit Positions
	x	404	405	Acknowledge Warnings	2	Yes	UINT32	-	32-bit field corresponding to the warning field
<b>Parameters</b>									
x		500	501	Standard Mode - Zero Flow Head	2	Yes	UINT32	0.01	Value for standard active mode. Units as configured on Pump Control Module.
x		502	503	Standard Mode - Design Head	2	Yes	UINT32	0.01	Value for standard active mode. Units as configured on Pump Control Module.
x		504	505	Standard Mode - Design Flow	2	Yes	UINT32	0.01	Value for standard active mode. Units as configured on Pump Control Module.
x		506	507	Standard Mode - Minimum Flow	2	Yes	UINT32	0.01	Value for standard active mode. Units as configured on Pump Control Module.
x		508	509	Mode 1 - Zero Flow Head	2	Yes	UINT32	0.01	Value for active mode 1. Units as configured on Pump Control Module.
x		510	511	Mode 1 - Design Head	2	Yes	UINT32	0.01	Value for active mode 1. Units as configured on Pump Control Module.
x		512	513	Mode 1 - Design Flow	2	Yes	UINT32	0.01	Value for active mode 1. Units as configured on Pump Control Module.
x		514	515	Mode 1 - Minimum Flow	2	Yes	UINT32	0.01	Value for active mode 1. Units as configured on Pump Control Module.
x		516	517	Mode 2 - Zero Flow Head	2	Yes	UINT32	0.01	Value for active mode 2. Units as configured on Pump Control Module.
x		518	519	Mode 2 - Design Head	2	Yes	UINT32	0.01	Value for active mode 2. Units as configured on Pump Control Module.
x		520	521	Mode 2 - Design Flow	2	Yes	UINT32	0.01	Value for active mode 2. Units as configured on Pump Control Module.
x		522	523	Mode 2 - Minimum Flow	2	Yes	UINT32	0.01	Value for active mode 2. Units as configured on Pump Control Module.
<b>Information</b>									
x		900	901	Pump Name / Tag name	8	N/A	ASCII	-	The pump name as a series of ASCII characters.
x		908	909	Serial Number	7	N/A	ASCII	-	Serial No. of the Pump represented by ASCII characters
x		915	916	Firmware Version	1	N/A	UINT16	00.00	Divide the number by 100 to get the major. minor version of the DEPC.
x		916	917	Hardware Version	1	N/A	UINT16	-	The Pump Control Module hardware version.
x		917	918	Modbus Version	1	N/A	UINT16	-	Version of the Armstrong Modbus version

### 3.2 BACNET OBJECTS - VERSION 1 - FOR FIRMWARE V1.16 AND OLDER

OBJECT ID	OBJECT NAME	READ/WRITE	COMMENTS
<b>Status</b>			
AV:100	Actual Speed	Read	In RPM
AV:101	Actual speed	Read	In %
AV:102	Motor Power	Read	Unit as configured in Pump Control Module
AV:103	Motor Input Voltage	Read	In Volts
AV:104	Motor Input Current	Read	In Amps
AV:105	Sensorless Head	Read	Unit as configured in Pump Control Module
AV:106	Sensorless Flow	Read	Unit as configured in Pump Control Module
AV:107	Total Flow	Read	Used for Parallel sensorless mode
AV:108	Total Power	Read	Used for Parallel sensorless mode
AV:109	No. Of Running Pumps	Read	Used for Parallel sensorless mode
AV:110	Max Sensorless Flow	Read	Unit as configured in Pump Control Module
AV:111	Max Sensorless Head	Read	Unit as configured in Pump Control Module
BV:2	Run Status	Read	1 → pump is running
<b>Counters</b>			
AV:275	Total Pump Running Hours	Read	
AV:276	Trip Pump Running Hours	Read/Write	Writing 0 to this register resets the counter.
AV:277	Total Controller Running Hours	Read	
AV:278	Present Controller Running Hours	Read	The running hours since the controller was powered on.
AV:279	Total Pump Running kWh Counter	Read	
AV:280	Trip Pump Running kWh Counter	Read/Write	Writing 0 to this register resets the counter.
<b>Control Settings</b>			
AV:300	Control Mode	Read	1 = Parallel; 2 = Inputs; 3 = Remote; 4 = Constant Flow; 5 = Constant Pressure; 6 = Linear Pressure; 7 = Quadratic Pressure; 8 = Quadratic Pressure with Maximum Flow; 9 = Quadratic Pressure with Minimum Flow; 10 = Quadratic Pressure with Minimum and Maximum Flow
AV:301	HOA State	Read/Write	0 = OFF; 1 = Hand Mode; 2 = Auto
AV:302	Active Parameters	Read/Write	1 = standard; 2 = mode 1 (heating mode); 3 = mode 2 (cooling mode)
AV:303	Minimum Speed Limit	Read	In RPM
AV:304	Maximum Speed Limit	Read	In RPM
AV:305	Hand Mode Speed	Read/Write	Unit as configured in Pump Control Module.
AV:306	BMS Set Speed	Read/Write	Unit as configured in Pump Control Module.
<b>Alarms and Warnings</b>			
AV:400	Alarms	Read	Refer to Alarms Table for Bit Positions
AV:401	Warnings	Read	Refer to Warnings Table for Bit Positions
AV:402	Acknowledge Warnings	Write	32-bit field corresponding to the warning field

OBJECT ID	OBJECT NAME	READ/WRITE	COMMENTS
<b>Parameters</b>			
AV:500	Standard Mode - Zero Flow Head	Read	Value for standard active mode. Unit as configured in Pump Control Module
AV:501	Standard Mode - Design Head	Read	Value for standard active mode. Unit as configured in Pump Control Module
AV:502	Standard Mode - Design Flow	Read	Value for standard active mode. Unit as configured in Pump Control Module
AV:503	Standard Mode - Minimum Flow	Read	Value for standard active mode. Unit as configured in Pump Control Module
AV:504	Mode 1 - Zero Flow Head	Read	Value for active mode 1. Unit as configured in Pump Control Module
AV:505	Mode 1 - Design Head	Read	Value for active mode 1. Unit as configured in Pump Control Module
AV:506	Mode 1 - Design Flow	Read	Value for active mode 1. Unit as configured in Pump Control Module
AV:507	Mode 1 - Minimum Flow	Read	Value for active mode 1. Unit as configured in Pump Control Module
AV:508	Mode 2 - Zero Flow Head	Read	Value for active mode 2. Unit as configured in Pump Control Module
AV:509	Mode 2 - Design Head	Read	Value for active mode 2. Unit as configured in Pump Control Module
AV:510	Mode 2 - Design Flow	Read	Value for active mode 2. Unit as configured in Pump Control Module
AV:511	Mode 2 - Minimum Flow	Read	Value for active mode 2. Unit as configured in Pump Control Module
<b>I/O</b>			
AI:0	Analog In 1	Read	As configured in Pump Control Module
AI:1	Analog In 2	Read	As configured in Pump Control Module
AO:0	Analog Out 1	Read	As configured in Pump Control Module
BI:0	Digital In:1	Read	As configured in Pump Control Module
BI:1	Digital In:2	Read	As configured in Pump Control Module
BO:0	Digital Out:1	Read	As configured in Pump Control Module
BO:1	Digital Out:2	Read	As configured in Pump Control Module
BV:0	Relay 1	Read	As configured in Pump Control Module
BV:1	Relay 2	Read	As configured in Pump Control Module



### 3.3 MODBUS REGISTER MAP - VERSION 2 - FOR FIRMWARE V1.17 AND NEWER

FUNCTION CODE		START ADDRESS	MODBUS REGISTER	DESCRIPTION	# OF REGISTERS	CHANGE DURING OPERATION	DATA TYPE	UNIT	NOTES
READ	WRITE								
0x03	0x06								
<b>Status</b>									
x		100	101	Actual Speed	1	N/A	UINT16	1 RPM	The current speed of the VFD in RPM.
x		101	102	Actual Speed	1	N/A	UINT16	0.1 %	The current speed of the VFD in % of the nominal motor speed.
x		102	103	Motor Power	2	N/A	UINT32	0.01	Units as configured on Pump Control Module.
x		104	105	Motor Input Voltage	1	N/A	UINT16	0.1 V	Voltage delivered by the VSD to the motor.
x		105	106	Motor Input Current	2	N/A	UINT32	0.01 A	Current delivered by the VSD to the motor.
x		107	108	Sensorless Head	2	N/A	UINT32	0.01	Units as configured on Pump Control Module.
x		109	110	Sensorless Flow	2	N/A	UINT32	0.01	Units as configured on Pump Control Module.
x		111	112	Total Flow	2	N/A	UINT32	0.01	Used for Parallel sensorless mode
x		113	114	Total Power	2	N/A	UINT32	0.01	Used for Parallel sensorless mode
x		115	116	Number of Running Pumps	1	N/A	UINT16	-	Used for Parallel sensorless mode
x		116	117	Max Sensorless Flow	2	N/A	UINT32	0.01	Units as configured on Pump Control Module.
x		118	119	Max Sensorless Head	2	N/A	UINT32	0.01	Units as configured on Pump Control Module.
x		122	123	Status	1	N/A	UINT16	-	Bit:0 = pump run status (0=not rotating, 1=rotating)
<b>I/O</b>									
x		200	201	Digital In	1	N/A	UINT16	-	Digital input 1 is bit 0 and input 2 is bit 1.
x		201	202	Analog In 1	2	N/A	UINT32	0.01 V, 0.01 mA	Units as configured on Pump Control Module
x		203	204	Analog In 2	2	N/A	UINT32	0.01 V, 0.01 mA	Units as configured on Pump Control Module
x		205	206	Analog Out 1	1	N/A	UINT16	0.01 mA	
x		206	207	Digital Out	1	N/A	UINT16	-	Digital output 1 is bit 0 and output 2 is bit 1.
x		207	208	Relays	1	N/A	UINT16	-	Relay 1 is bit 0 and relay 2 is bit 1.
<b>Units</b>									
x		250	251	Flow Units	1	N/A	UINT16	-	1 = l/s; 2 = m <sup>3</sup> /h; 3 = g/m
x		251	252	Pressure Units	1	N/A	UINT16	-	1 = bar; 2 = kPa; 3 = psi; 4 = ft; 5 = m
x		252	253	Power Units	1	N/A	UINT16	-	1 = kw; 2 = hp
x		253	254	Speed Units	1	N/A	UINT16	-	1 = RPM; 2 = %
x		254	255	Temperature Units	1	N/A	UINT16	-	1 = Degrees Celsius; 2 = Degrees Fahrenheit
<b>Counters</b>									
x		275	276	Total Pump Running Hours	2	N/A	UINT32	1 h	
x	x	277	278	Trip Pump Running Hours	2	N/A	UINT32	1 h	Writing 0 to this register resets the counter.
x		279	280	Total Controller Running Hours	2	N/A	UINT32	1 h	
x		281	282	Present Controller Running Hours	2	N/A	UINT32	1 h	The running hours since the controller was powered on.
x		283	284	Total Pump Running kWh Counter	2	N/A	UINT32	1 kWh	
x	x	285	286	Trip Pump Running kWh Counter	2	N/A	UINT32	1 kWh	Writing 0 to this register rests the counter.

FUNCTION CODE		START ADDRESS	MODBUS REGISTER	DESCRIPTION	# OF REGISTERS	CHANGE DURING OPERATION	DATA TYPE	UNIT	NOTES
READ	WRITE								
0x03	0x06								
<b>Control Settings</b>									
x		300	301	Control Mode	1	Yes	UINT16	-	1 = Parallel; 2 = Inputs; 3 = Remote; 4 = Constant Flow; 5 = Constant Pressure; 6 = Linear Pressure; 7 = Quadratic Pressure; 8 = Quad Pressure Maximum; 9 = Quad Pressure Minimum; 10 = Quadratic Pressure Max/Min
x	x	301	302	HOA State	1	Yes	UINT16	-	0 = Off; 1 = Hand; 2 = Auto
x	x	302	303	Active Parameters	1	Yes	UINT16	-	1 = standard; 2 = mode 1 (heating mode); 3 = mode 2 (cooling mode)
x	x	303	304	Minimum Speed Limit	1	Yes	UINT16	1	In RPM
x	x	304	305	Maximum Speed Limit	1	Yes	UINT16	1	In RPM.
x	x	305	306	Hand Mode Speed	1	Yes	UINT16	0.1	Units as configured on Pump Control Module.
x	x	306	307	BMS Set Speed	1	Yes	UINT16	0.1	Units as configured on Pump Control Module.
x	x	308	309	Start/Stop	1	Yes	UINT16	-	0 = stop pump; 1 = start pump
<b>Alarms and Warnings</b>									
x		400	401	Alarms	2	N/A	UINT32	-	Refer to alarms table for bit positions.
x		402	403	Warnings	2	N/A	UINT32	-	Refer to warnings table for bit positions.
x	x	404	405	Acknowledge Warnings	2	Yes	UINT32	-	32-bit field corresponding to the warning field.
<b>Parameters</b>									
x		500	501	Standard Mode - Zero Flow Head	2	Yes	UINT32	0.01	Value for standard active mode. Units as configured on Pump Control Module.
x		502	503	Standard Mode - Design Head	2	Yes	UINT32	0.01	Value for standard active mode. Units as configured on Pump Control Module.
x		504	505	Standard Mode - Design Flow	2	Yes	UINT32	0.01	Value for standard active mode. Units as configured on Pump Control Module.
x		506	507	Standard Mode - Minimum Flow	2	Yes	UINT32	0.01	Value for standard active mode. Units as configured on Pump Control Module.
x		508	509	Mode 1 - Zero Flow Head	2	Yes	UINT32	0.01	Value for active mode 1. Units as configured on Pump Control Module.
x		510	511	Mode 1 - Design Head	2	Yes	UINT32	0.01	Value for active mode 1. Units as configured on Pump Control Module.
x		512	513	Mode 1 - Design Flow	2	Yes	UINT32	0.01	Value for active mode 1. Units as configured on Pump Control Module.
x		514	515	Mode 1 - Minimum Flow	2	Yes	UINT32	0.01	Value for active mode 1. Units as configured on Pump Control Module.
x		516	517	Mode 2 - Zero Flow Head	2	Yes	UINT32	0.01	Value for active mode 2. Units as configured on Pump Control Module.
x		518	519	Mode 2 - Design Head	2	Yes	UINT32	0.01	Value for active mode 2. Units as configured on Pump Control Module.
x		520	521	Mode 2 - Design Flow	2	Yes	UINT32	0.01	Value for active mode 2. Units as configured on Pump Control Module.
x		522	523	Mode 2 - Minimum Flow	2	Yes	UINT32	0.01	Value for active mode 2. Units as configured on Pump Control Module.
x	x	539	540	Control Setpoint	2	Yes	UINT32	0.01	Value and unit as configured on pump control mode (constant pressure or constant flow)
<b>Information</b>									
x		900	901	Pump Name / Tag name	8	N/A	ASCII	-	The pump name as a series of ASCII characters.
x		908	909	Serial Number	7	N/A	ASCII	-	Serial No. of the Pump represented by ASCII characters
x		915	916	Firmware Version	1	N/A	UINT16	00.00	Divide the number by 100 to get the major. minor version of the DEPC.
x		916	917	Hardware Version	1	N/A	UINT16	-	The Pump Control Module hardware version.
x		917	918	BMS Modbus Version	1	N/A	UINT16	-	Version of the Armstrong Modbus registers used.
x		918	919	Firmware Patch Version	1	N/A	UINT16	00	Patch version of the DEPC. To be appended to firmware version register.

### 3.4 BACNET OBJECTS - VERSION 2 - FOR FIRMWARE V1.17 AND NEWER

OBJECT ID	OBJECT NAME	READ/WRITE	COMMENTS
<b>Status</b>			
AV:100	Actual Speed	Read	In RPM
AV:101	Actual speed	Read	In %
AV:102	Motor Power	Read	Unit as configured in Pump Control Module
AV:103	Motor Input Voltage	Read	In Volts
AV:104	Motor Input Current	Read	In Amps
AV:105	Sensorless Head	Read	Unit as configured in Pump Control Module
AV:106	Sensorless Flow	Read	Unit as configured in Pump Control Module
AV:107	Total Flow	Read	Used for Parallel sensorless mode
AV:108	Total Power	Read	Used for Parallel sensorless mode
AV:109	No. Of Running Pumps	Read	Used for Parallel sensorless mode
AV:110	Max Sensorless Flow	Read	Unit as configured in Pump Control Module
AV:111	Max Sensorless Head	Read	Unit as configured in Pump Control Module
BV:2	Run Status	Read	1 → pump is running
<b>Counters</b>			
AV:275	Total Pump Running Hours	Read	
AV:276	Trip Pump Running Hours	Read/Write	Writing 0 to this register resets the counter.
AV:277	Total Controller Running Hours	Read	
AV:278	Present Controller Running Hours	Read	The running hours since the controller was powered on.
AV:279	Total Pump Running kWh Counter	Read	
AV:280	Trip Pump Running kWh Counter	Read/Write	Writing 0 to this register resets the counter.
<b>Control Settings</b>			
AV:300	Control Mode	Read	1 = Parallel; 2 = Inputs; 3 = Remote; 4 = Constant Flow; 5 = Constant Pressure; 6 = Linear Pressure; 7 = Quadratic Pressure; 8 = Quadratic Pressure with Maximum Flow; 9 = Quadratic Pressure with Minimum Flow; 10 = Quadratic Pressure with Minimum and Maximum Flow
AV:301	HOA State	Read/Write	0 = OFF; 1 = Hand Mode; 2 = Auto
AV:302	Active Parameters	Read/Write	1 = standard; 2 = mode 1 (heating mode); 3 = mode 2 (cooling mode)
AV:303	Minimum Speed Limit	Read	in RPM
AV:304	Maximum Speed Limit	Read	in RPM
AV:305	Hand Mode Speed	Read/Write	Unit as configured in Pump Control Module.
AV:306	BMS Set Speed	Read/Write	Unit as configured in Pump Control Module.
BV:14	Start/Stop	Read/Write	Start/stop of pump

OBJECT ID	OBJECT NAME	READ/WRITE	COMMENTS
<b>Alarms and Warnings</b>			
AV:400	Alarms	Read	Refer to Alarms Table for Bit Positions
AV:401	Warnings	Read	Refer to Warnings Table for Bit Positions
AV:402	Acknowledge Warnings	Read/Write	32-bit field corresponding to the warning field
<b>Parameters</b>			
AV:500	Standard Mode - Zero Flow Head	Read/Write	Value for standard active mode. Unit as configured in Pump Control Module
AV:501	Standard Mode - Design Head	Read/Write	Value for standard active mode. Unit as configured in Pump Control Module
AV:502	Standard Mode - Design Flow	Read/Write	Value for standard active mode. Unit as configured in Pump Control Module
AV:503	Standard Mode - Minimum Flow	Read/Write	Value for standard active mode. Unit as configured in Pump Control Module
AV:504	Mode 1 - Zero Flow Head	Read/Write	Value for active mode 1. Unit as configured in Pump Control Module
AV:505	Mode 1 - Design Head	Read/Write	Value for active mode 1. Unit as configured in Pump Control Module
AV:506	Mode 1 - Design Flow	Read/Write	Value for active mode 1. Unit as configured in Pump Control Module
AV:507	Mode 1 - Minimum Flow	Read/Write	Value for active mode 1. Unit as configured in Pump Control Module
AV:508	Mode 2 - Zero Flow Head	Read/Write	Value for active mode 2. Unit as configured in Pump Control Module
AV:509	Mode 2 - Design Head	Read/Write	Value for active mode 2. Unit as configured in Pump Control Module
AV:510	Mode 2 - Design Flow	Read/Write	Value for active mode 2. Unit as configured in Pump Control Module
AV:511	Mode 2 - Minimum Flow	Read/Write	Value for active mode 2. Unit as configured in Pump Control Module
AV:520	Control Setpoint	Read/Write	Value and unit as configured on pump control mode (constant pressure or constant flow)
<b>INFORMATION</b>			
AV:900	BMS BACnet Version	Read	Version of the Armstrong BACnet points used.
<b>I/O</b>			
AI:0	Analog In 1	Read	As configured in Pump Control Module
AI:1	Analog In 2	Read	As configured in Pump Control Module
AV:113	Analog Out 1	Read	As configured in Pump Control Module
BI:0	Digital In 1	Read	As configured in Pump Control Module
BI:1	Digital In 2	Read	As configured in Pump Control Module
BV:15	Digital Out 1	Read	As configured in Pump Control Module
BV:16	Digital Out 2	Read	As configured in Pump Control Module
BV:0	Relay 1	Read	As configured in Pump Control Module
BV:1	Relay 2	Read	As configured in Pump Control Module

## 4.0 OPERATION

### 4.1 START-UP CHECKLIST



Particular care must be taken to check the following before the pump is put into operation:

- A Pump primed?
- B Rotation **ok**?
- C Lubrication **ok**?
- D Pipe work properly supported?
- E Voltage supply **ok**?
- F Overload protection **ok**?
- G Is the system clean?
- H Is the area around the pump clean?

#### NOTE: FOR DEPM2 MOTORS:

Ensure that the STO jumpers are in place

## Warranty

Does not cover any damages to the equipment resulting from failure to observe the above precautions. Refer to Armstrong General Terms and Warranty sheet. Contact your local Armstrong representative for full information.

### 4.2 STARTING PUMP



Ensure that the pump turns freely by hand, or with some gentle mechanical help such as a strap or Allen key in coupling bolt.

Ensure that all protective guarding is securely fixed in position.

The pump must be fully primed on start up. Fill the pump casing with liquid and rotate the shaft by hand to remove any air trapped in the impeller. On split-coupled Design Envelope units any air trapped in the casing as the system is filled must be removed by the manual air vent in the seal flush line. **Ensure entrained air is removed from Design Envelope pumps, prior to starting, through the air vent on the seal flush line. Open vent until clear of air.**

Design Envelope close-coupled units are fitted with seal flush/vent lines piped to the pump suction area. When these units operate, residual air is drawn out of the pump towards the suction piping. energize the motor momentarily and check that the rotation corresponds with the directional arrow on the pump casing (clockwise when viewed from non-drive end of motor).

Start the pump with the discharge valve closed and the suction valve open, then gradually open the discharge valve when the motor is at operating speed. The discharge valve may be **cracked** or open slightly at start up to help eliminate trapped air.

**When stopping the pump:** Close the discharge valve and de-energize the motor.

**Do not** run the pump against a closed discharge valve at full speed for an extended period of time (a few minutes maximum.)

Should the pump be noisy or vibrate on start-up a common reason is overstated system head. Check this by calculating the pump operating head by deducting the suction pressure gauge value from the discharge gauge reading. Convert the result into the units of the pump head as stated on the pump nameplate and compare the values. The system designer or operator should be made aware of this soon as some adjustment may be required to the drive settings to make the pump suitable for the system as installed.



Check rotation arrow prior to operating the unit. The rotation of all Armstrong 4300 & 4380 Vertical In-Line units is clockwise when viewed from behind the motor (NDE).

#### 4.2.1 AUTO FLOW BALANCING

Auto-Flow Balancing automatically determines the control curve between the design flow at the on-site system head, and the minimum (zero-flow) head that will typically be lowered (reset).

Often the actual system head is less than expected, and the pump will operate further to the right of the curve at a higher flow rate than it was designed for due to less system resistance. The Auto Flow Balancing function performs a scan of the sensorless map against the actual system to establish the actual head for the design flow. The minimum (zero-flow) head will be reset according to the actual head at the design flow - the factory default is 40% of the design head, but can be lowered further for more energy savings if all zones are still satisfied.

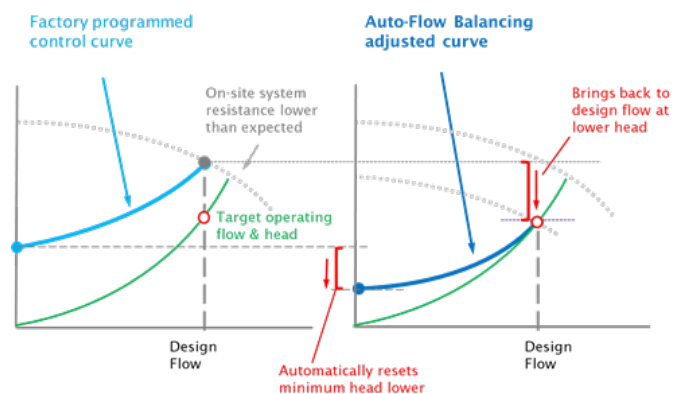

For buildings that are commissioned in multiple stages, or where the design flow changes each time, the Auto Flow Balancing function can be run at the beginning of each stage.

From the touch screen, go to **Pump Configuration -> Auto Flow Balancing**, then follow the on-screen instructions. The Auto Flow Balancing scan takes approximately 3 minutes to complete.

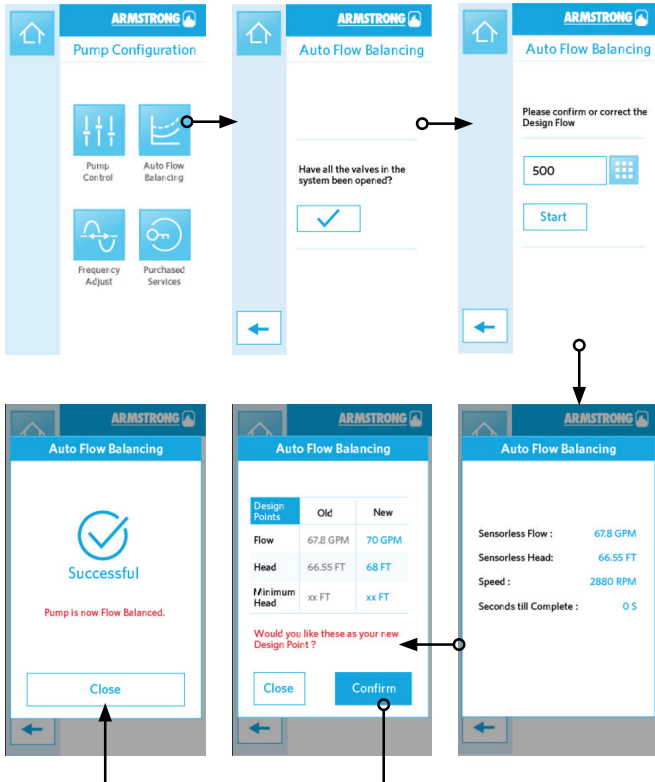

### 4.3 TOUCH SCREEN

#### 4.3.1 LOGIN

Default Password 1234

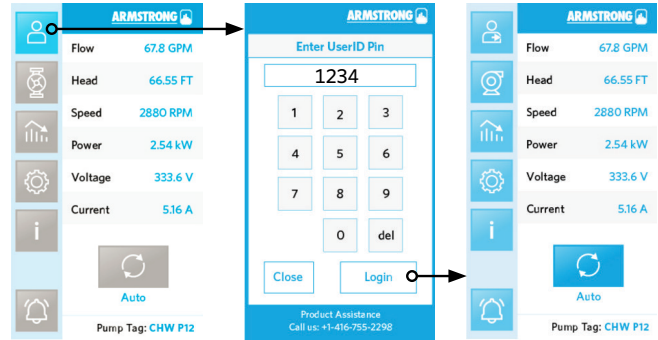

#### 4.3.2 LOGOUT

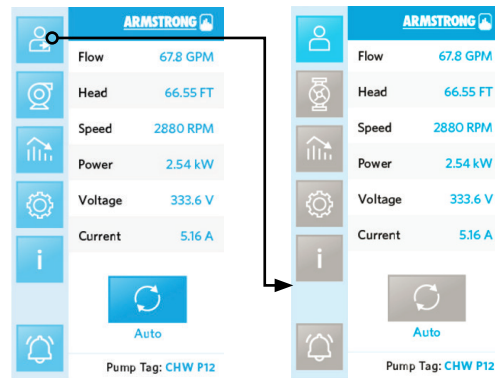

### 4.3.3 ABOUT

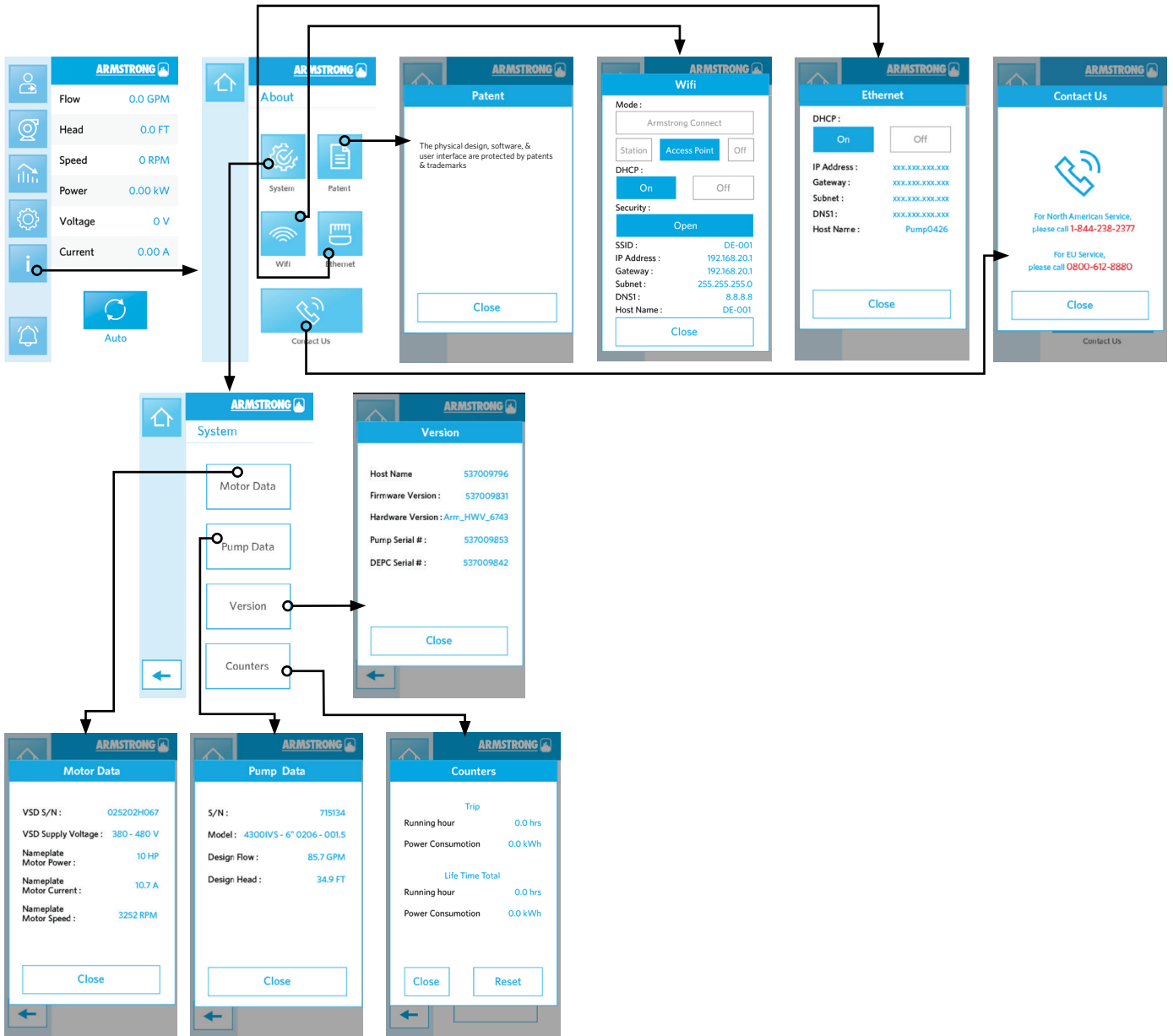

Click on **Reset** to reset Trip counters

4.3.4 GENERAL SETTINGS

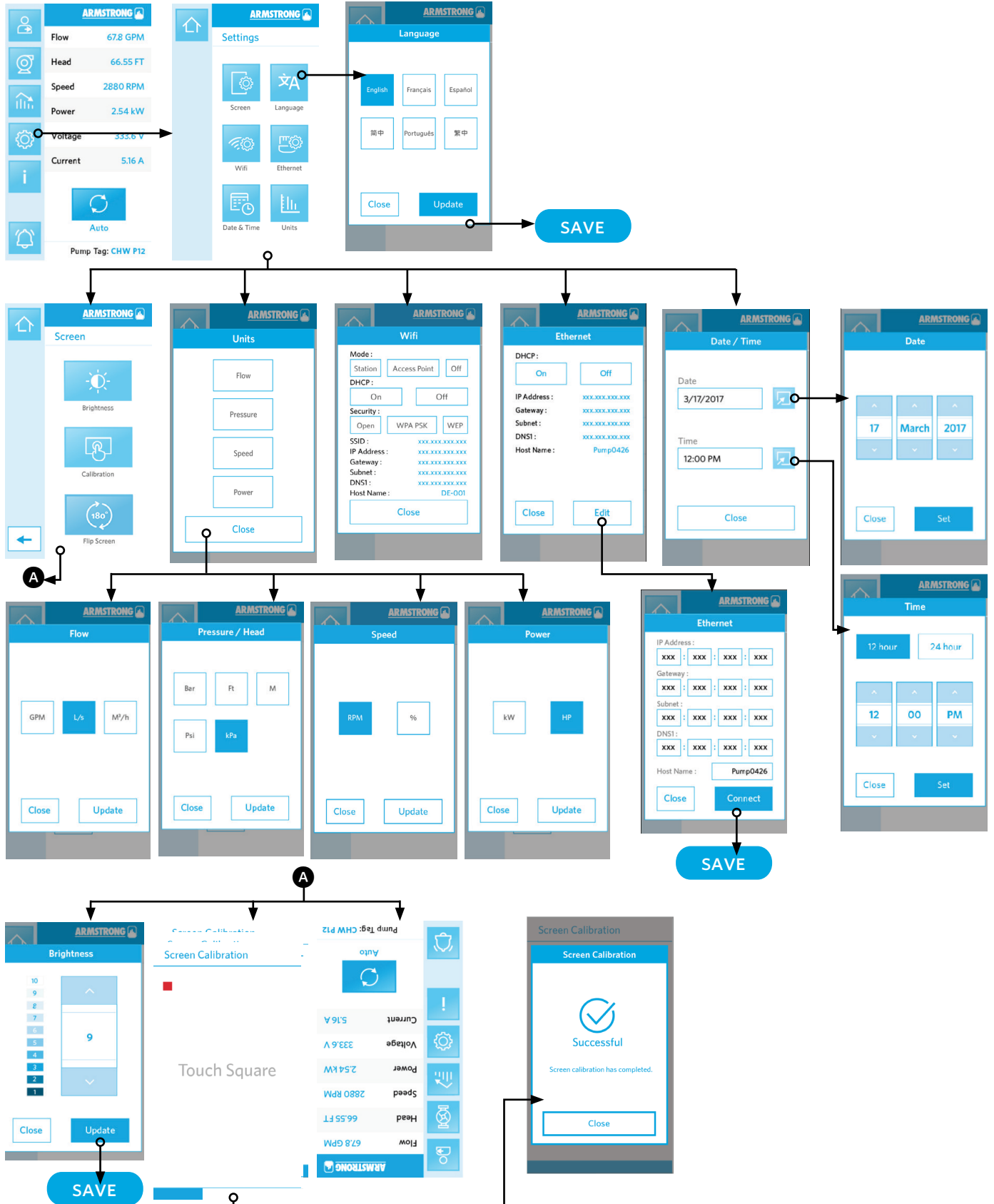



### 4.3.5 MANUAL/AUTO MODE

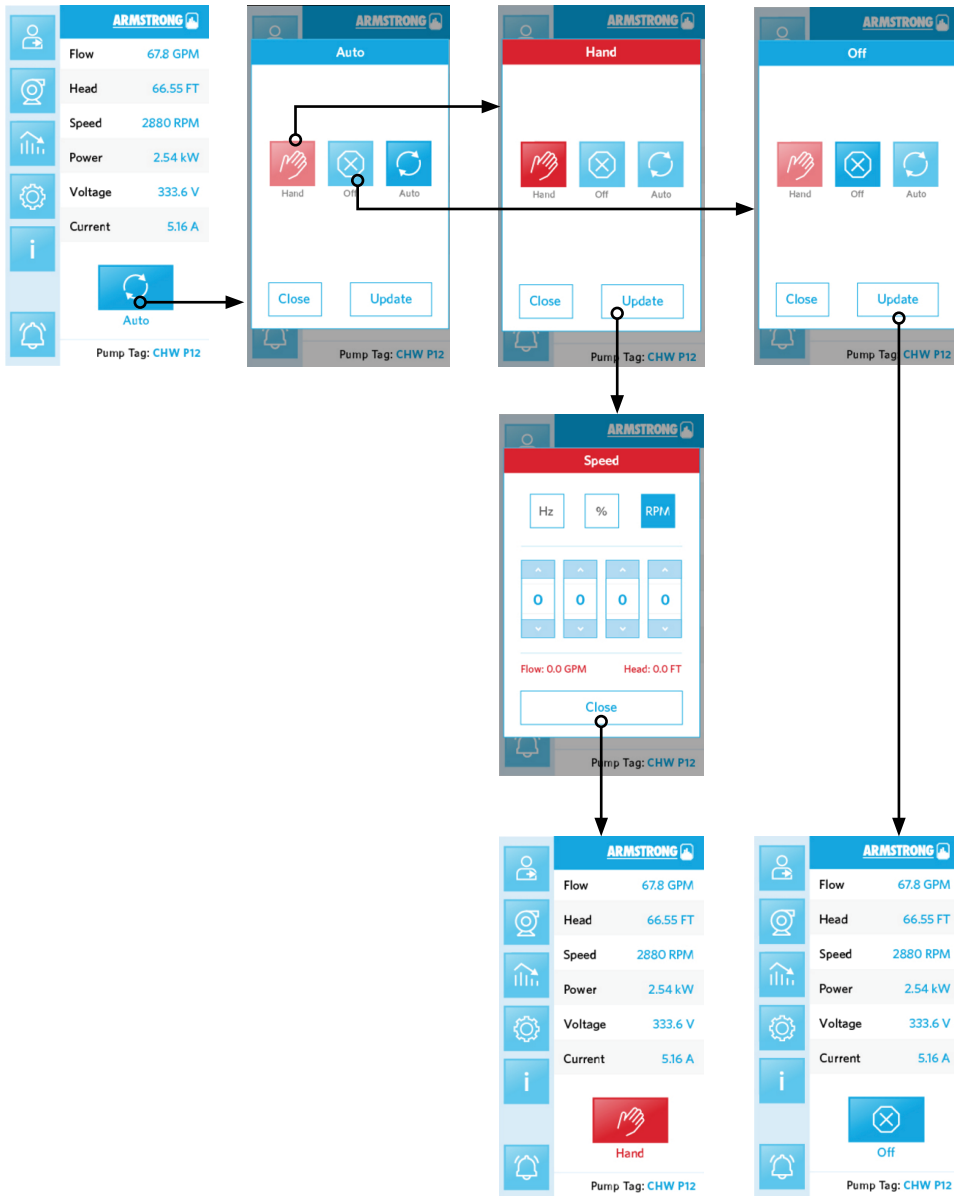

4.3.6 PUMP CONTROL

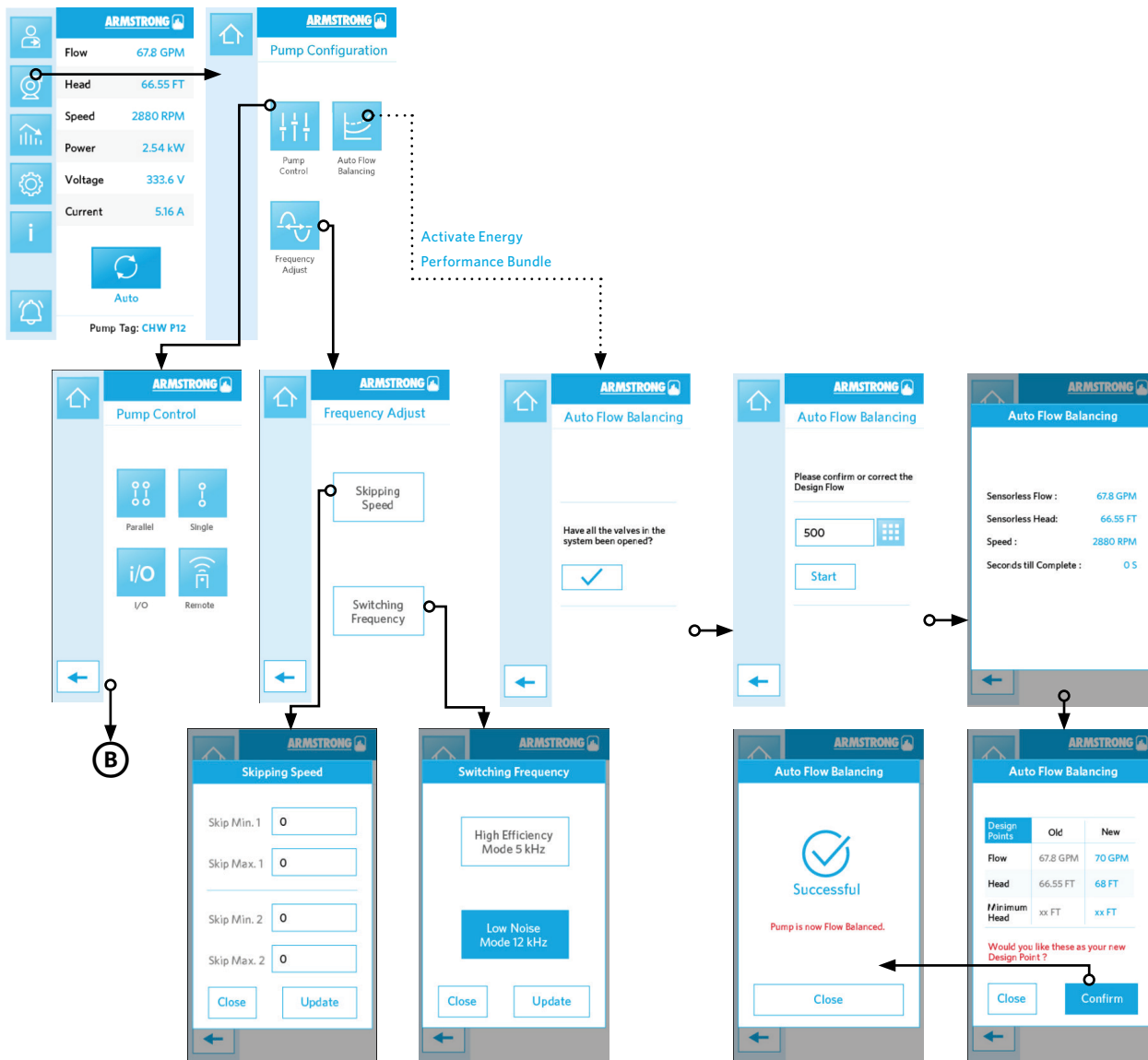

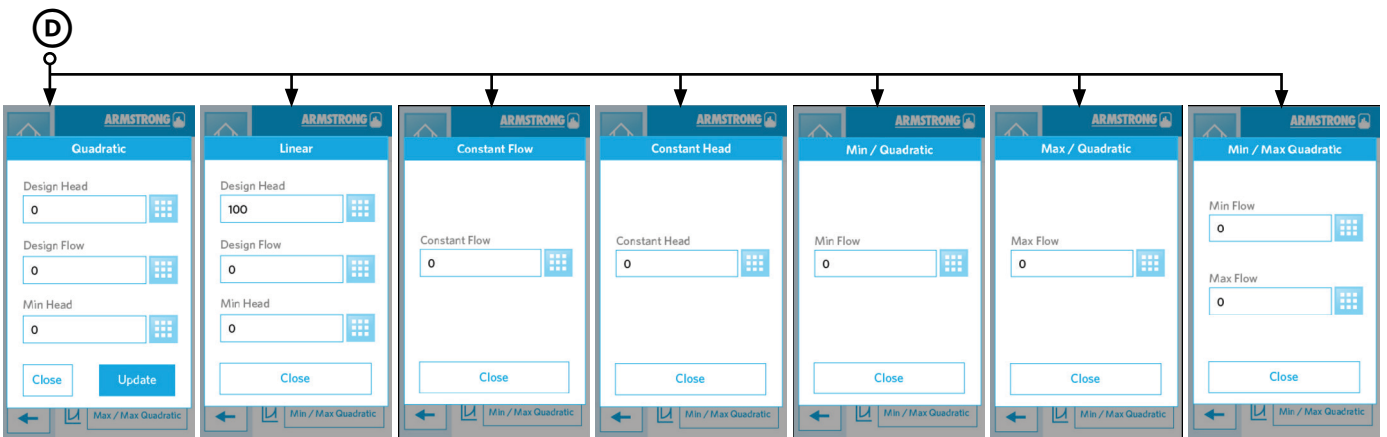
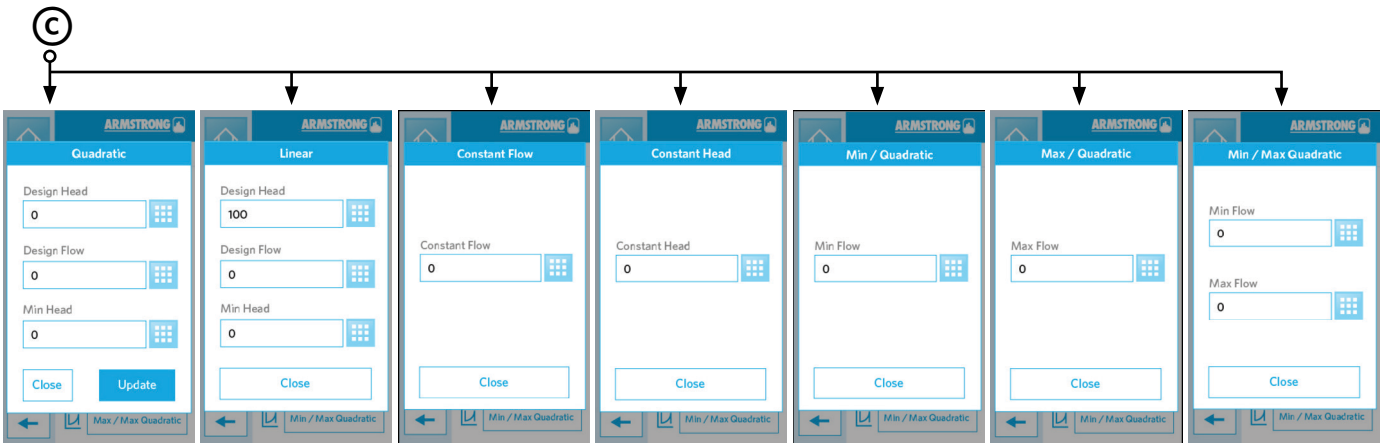
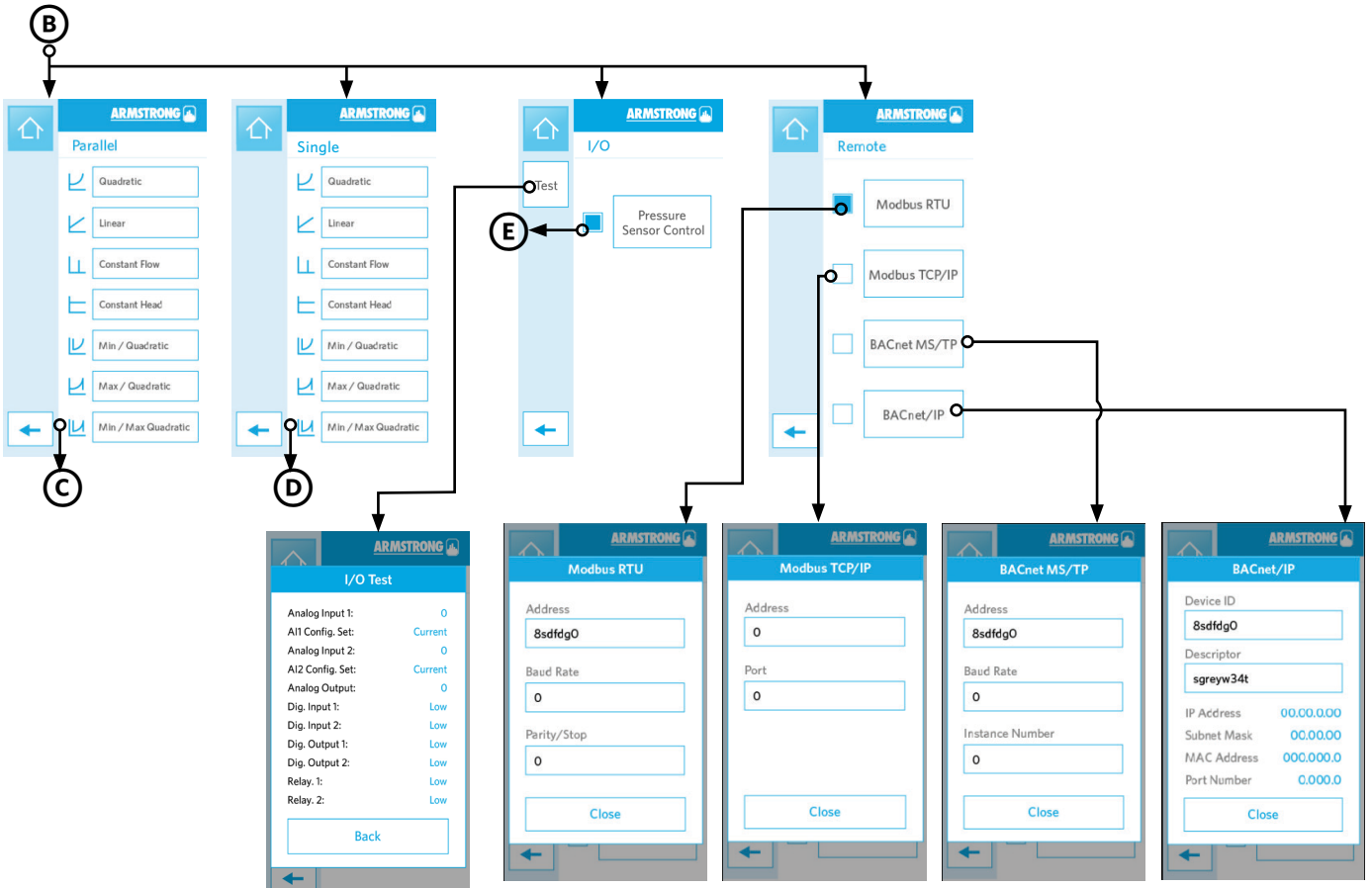

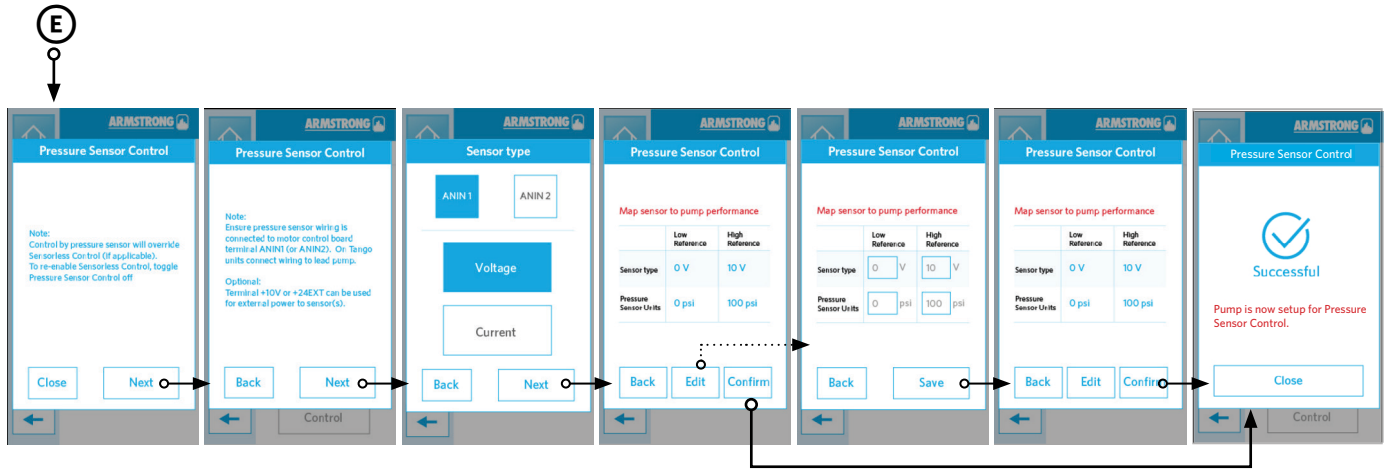

### 4.3.7 ALARMS & WARNINGS

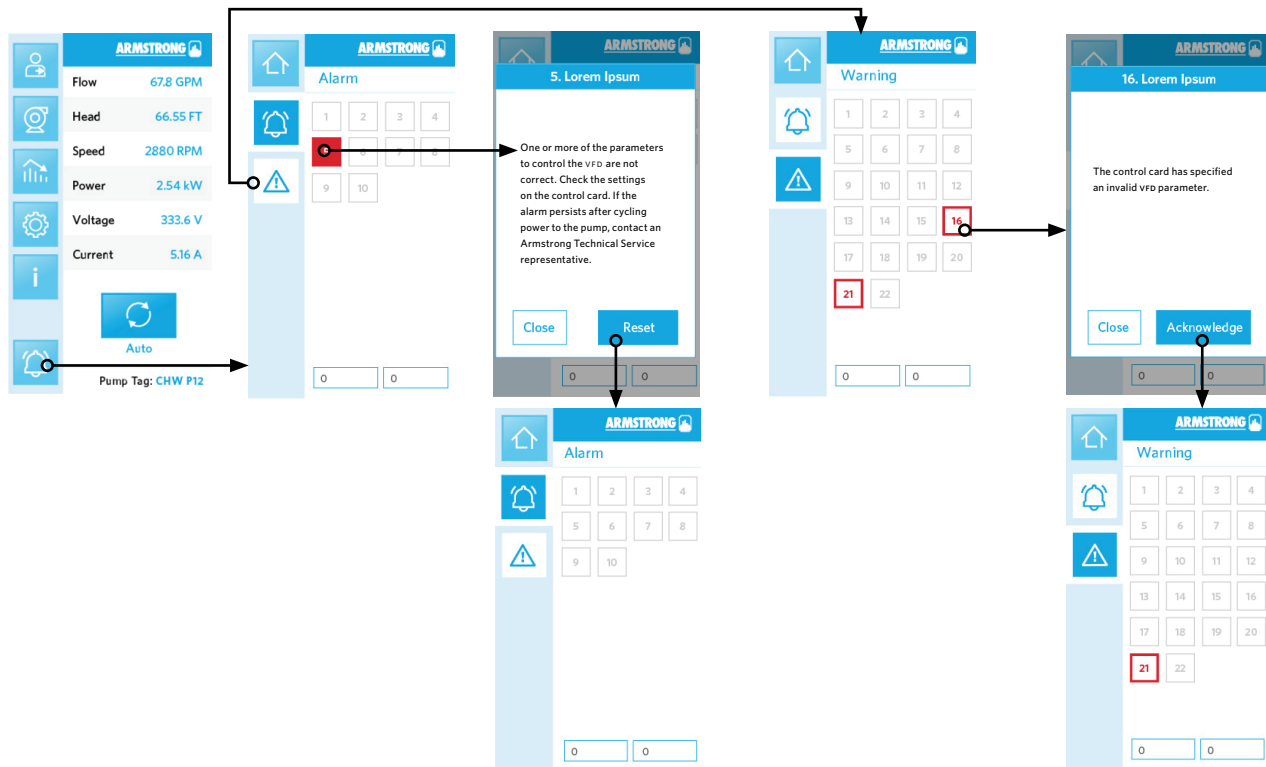

### 4.3.8 TREND-GRAPH

There are 3 parameters that can be trended on the touch screen interface:

- Power
- Flow
- Head

Which allows users to see a quick history of key performance data.

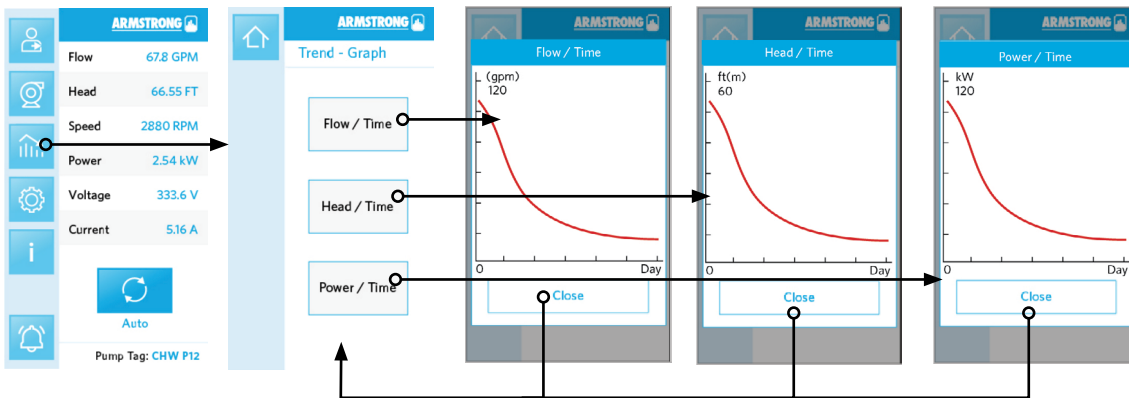

To see a more comprehensive view of the trends, the pump data can be exported in CSV format for review and analysis on a separate computing device.

### 4.3.9 BRIGHTNESS ADJUSTMENT

To adjust the brightness of the touch screen interface, go to **Settings -> Brightness**.

10 = highest brightness, 1 = lowest brightness

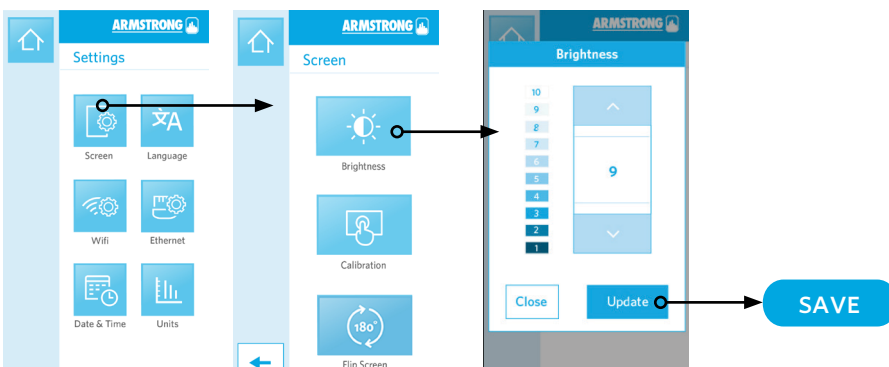

### 4.3.10 TOUCH SCREEN CALIBRATION

If you are having issues with the touch screen, including:

- Being unable to access items to the edge of the screen
- Some buttons from the display are unresponsive

The touch screen may require re-calibration. To calibrate the touch screen, go to **Settings -> Screen -> Calibration**

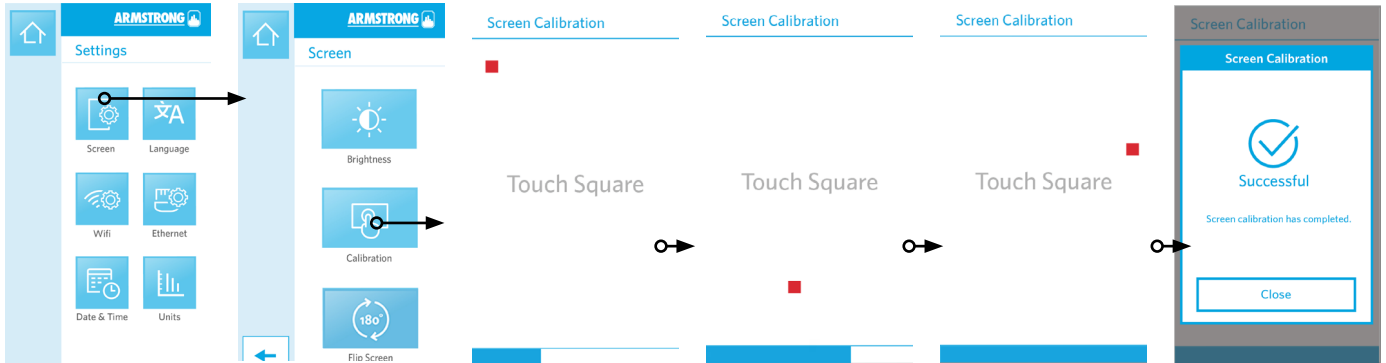

Follow the following 3-step calibration sequence (touching the squares) to reset the display coordinates.

If you are unable to access the Calibration function from the touch screen itself, connect the pump to the webserver and go to **Settings -> General -> Recalibrate LCD Screen**. This will trigger the calibration sequence on the touch screen of the pump. Follow the above 3-step calibration sequence to reset the display coordinates.

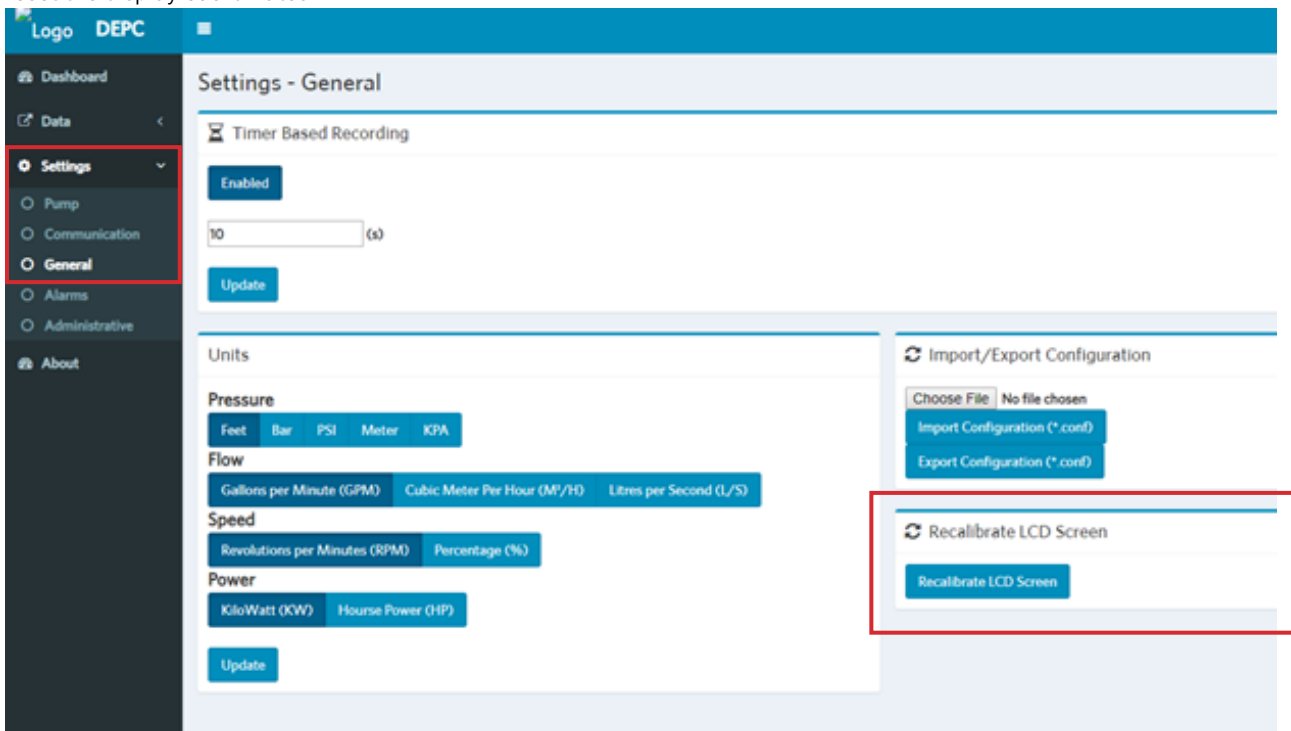

#### 4.3.11 DATA LOGGING

Data logs can be used for energy performance analyses or to troubleshoot system issues. The data logs can be used with a building automation system (BAS) or for each standalone pump. Each pump controller logs the following data parameters over pre-defined time intervals (default is 5 minutes).

- Speed (rpm)
- Power (kW)
- Current (A)
- Flow (gpm)
- Head (ft)
- Analog Input 1
- Analog Input 2
- Analog Output
- Digital Input
- Digital Output
- Alarms
- Warnings
- kW-hours

The DEPC stores up to 3 months of data, at 5 min. intervals. More data storage is available on the cloud server if the pump is connected to the internet and has an active Pump Manager subscription.

#### Export Log File

Start date is: Wednesday, November 28, 2018

End date is: Friday, November 30, 2018

November 2018							
<	Sun	Mon	Tue	Wed	Thu	Fri	Sat
44	28	29	30	31	01	02	03
45	04	05	06	07	08	09	10
46	11	12	13	14	15	16	17
47	18	19	20	21	22	23	24
48	25	26	27	28	29	30	01
49	02	03	04	05	06	07	08

November 2018							
<	Sun	Mon	Tue	Wed	Thu	Fri	Sat
44	28	29	30	31	01	02	03
45	04	05	06	07	08	09	10
46	11	12	13	14	15	16	17
47	18	19	20	21	22	23	24
48	25	26	27	28	29	30	01
49	02	03	04	05	06	07	08

[Export History](#)  
History is in csv format.

Connect the DEPC to the Webserver, in the **Data -> Trends -> Export Log File** section.

Select the start date, the end date, and then click **Export History** to download the data log file in CSV format.

### 4.4 WEB INTERFACE

Armstrong Strongly recommends to use Google Chrome browser to access DEPC web interface. Other browsers might be used but Google Chrome will guarantee the best operation.

#### 4.4.1 CONNECTING VIA ETHERNET

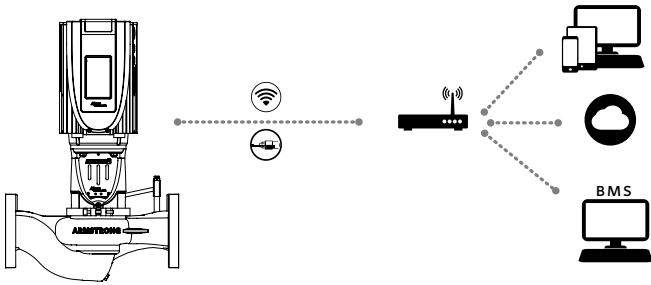

Connect your device to the router via wifi or by Ethernet cable.

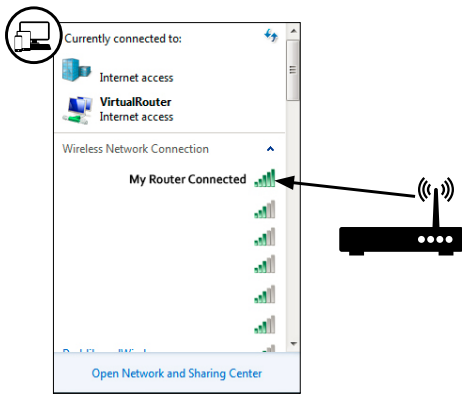

#### 4.4.2 CONNECTING VIA WIFI

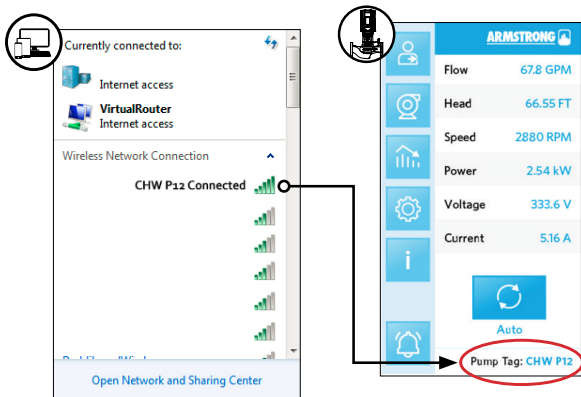

At the web browser address bar, type the Pump's IP (from Pump's About screen, Ethernet IP address).

Default user level 1 Password: Armstrong1

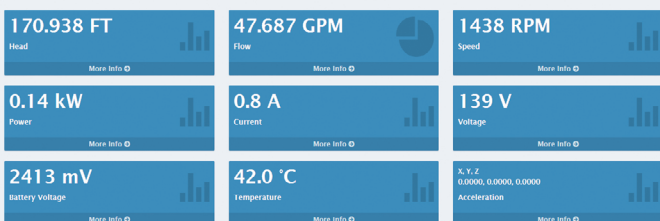

To access the control modes:

Press settings → Pump

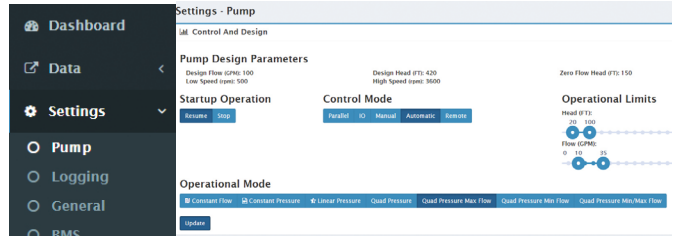

Press settings → General, select desired units and click Update



To set the interval for timer based recording: Press settings → General, click on enable and input the desired time (default is 300 seconds)

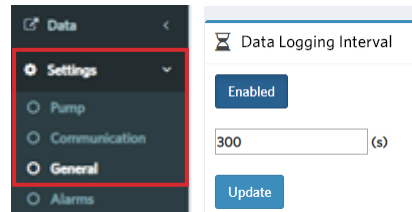

To Import/Export configuration files: Press Settings → General, select a file and click on **Import Configuration** to input. Click on Export Configuration to export

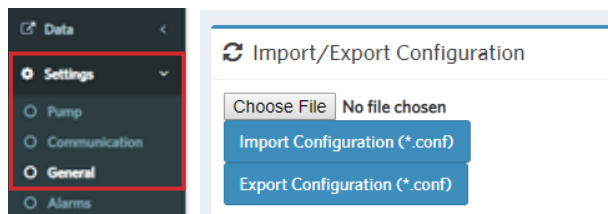



To modify Date/Time: click Settings → General and modify date and time

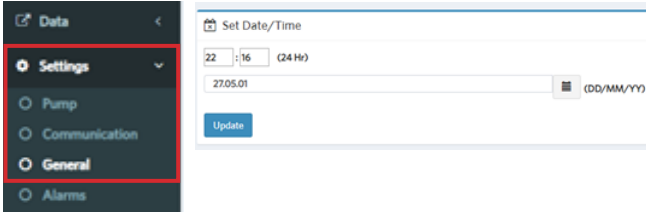

To access the control modes: Press settings → Pump

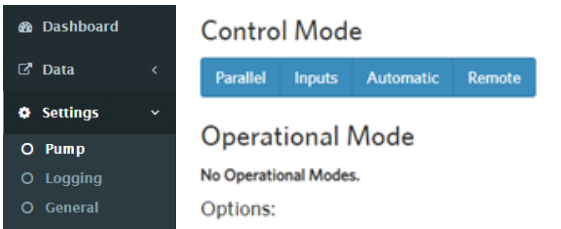

To select Version 1 or 2 of BMS settings, Click on Remote mode and select Version 1 or 2.

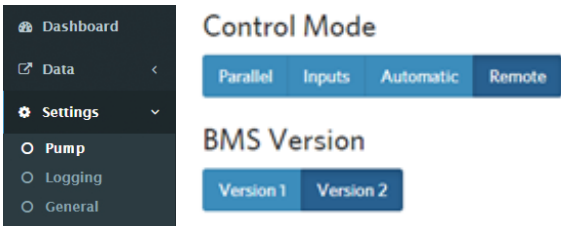

Settings → Pump,

To change motor ramp up and down settings, input in **Motor Ramp up Time** and **Motor Ramp Down Time**

To change Pump high and Low Speed, input RPM in **High Speed Limit** and **Low Speed Limit**

To change pump tag, input new tag in **Pump Tag**



To modify out settings: Settings → Pump,

To modify digital outputs: enable in Outputs and select desire,

To modify analog outputs: click enable and speed.

To modify relay settings: enable Relay functions and select desired settings



To enable Armstrong Connect: Settings → Communication, and click on Armstrong Connect to enable

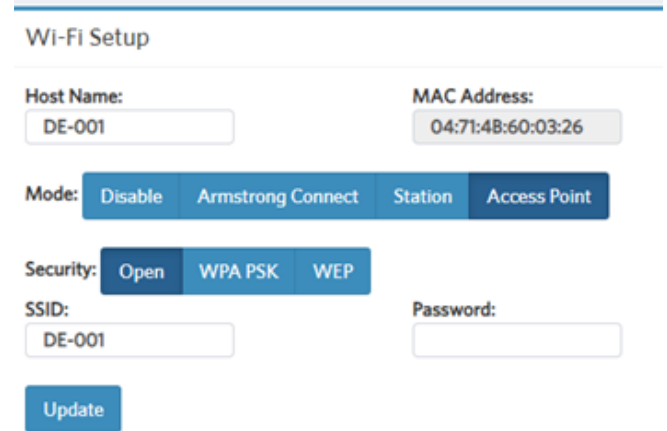

To set the BACnet max info from, Settings → Communication, enable BACnet Serial and input in **Max Info. Frame**

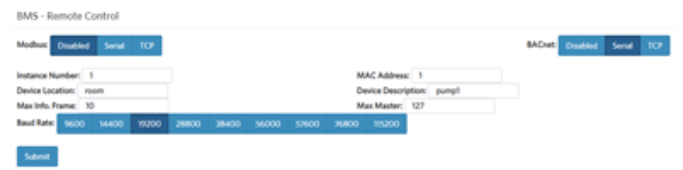

**4.5 DESIGN ENVELOPE FLOW READOUT TOLERANCE**

Tolerance on flow and head readings between test stand instrumentation and Design Envelope controller readout will be within 5% of BEP flow & head values for all Design Envelope sensorless pump selections.

The same BEP flow & head tolerance values will be carried to the Design Envelope selection point for that model (Guarantee point, to ANSI 40.6 Hydraulic Institute Standard-See FIG. 4.1), as follows:

**FIG. 4.1**

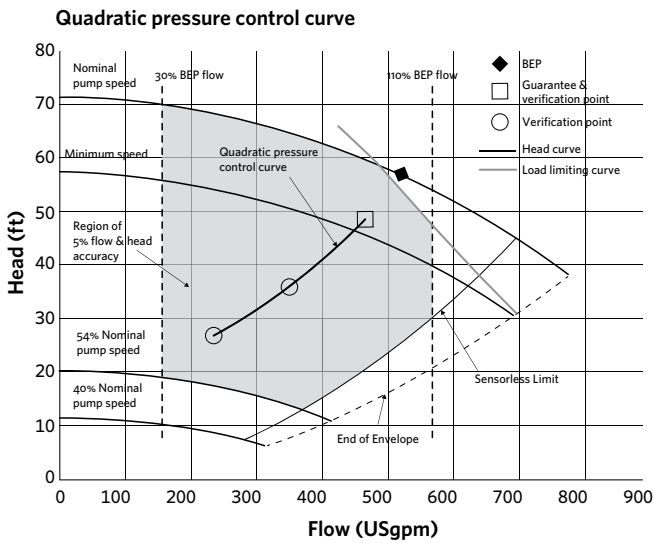

The tolerance is applicable when the flow is between 30% and 110% of BEP flow at Nominal Pump Speed; and the operating point is at 54% of Nominal Pump Speed, or greater. Nominal Pump Speed is displayed as the top speed on any Design Envelope pump curve.

**4.6 NOISE LEVELS**

**Motor Maximum Sound Pressure Level**

PUMP MODEL	kW	[dBA]
2580-00.25	0.25	63
2580-00.37	0.37	63
2580-00.55	0.55	67
2580-00.75	0.75	67
3212-00.55	0.55	63
3212-00.75	0.75	63
3212-001.1	1.1	68
3212-001.5	1.5	68
3212-002.2	2.2	69.2
4080-00.75	0.75	68
4080-001.1	1.1	68
4012-001.1	1.1	64
4012-001.5	1.5	64
4012-002.2	2.2	62.6
4012-003.0	3	69.2
4012-004.0	4	69.2
5012-001.1	1.1	64
5012H-001.1	1.1	64
5012-001.5	1.5	64
5012H-001.5	1.5	64
5012-002.2	2.2	62.6
5012H-002.2	2.2	62.6
5012-003.0	3	62.6
5012-004.0	4	69.2
5012-005.5	5.5	69.2
5012-007.5	7.5	80.3
6512-001.1	1.1	64
6512-001.5	1.5	64
6512-002.2	2.2	62.6
6512-003.0	3	62.6
6512-004.0	4	69.2
6512-005.5	5.5	69.2
8012-002.2	2.2	62.6
8012-003.0	3	62.6
8012-004.0	4	73.2
8012-005.5	5.5	69.2
8012-007.5	7.5	77.0

Sound pressure level measurements made in accordance with ISO 3744, ± 3dB tolerance (measuring level A-Weighted)

Data based on motor frames at 380-480V. Audible noise is mainly from the motor fan and will be reduced when operating at part load

## 5.0 CONTROL MODES

### 5.1 CONSTANT FLOW

Design Envelope pumps can be configured to maintain a constant pump flow in a system as the system head varies. This effectively simulates speed control by a flow meter in the piping.

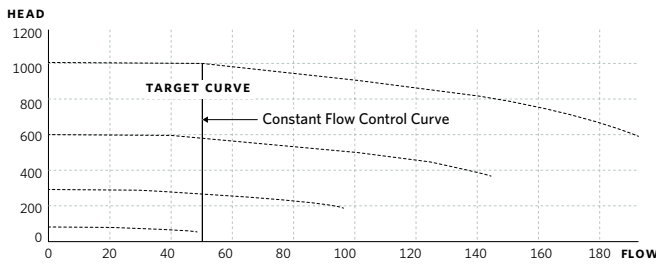

### 5.2 CONSTANT PRESSURE

Design Envelope pumps can be configured to maintain a constant pump head in a system as the demand varies. This effectively simulates the mounting of a differential pressure sensor at, or near, the pump.

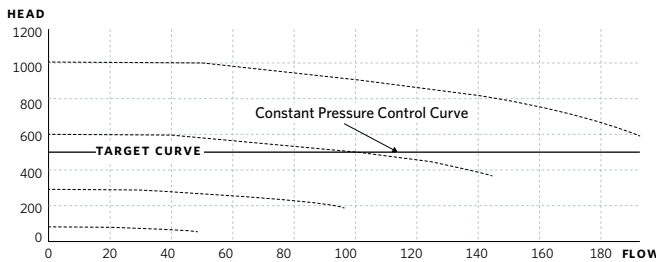

### 5.3 LINEAR PRESSURE

Linear Pressure Control is where the controller is set to control the speed according to a control 'curve' between max and min flow. This type of control will change the pump speed to ensure the pump operates on the projected linear control curve, where the pump head varies directly with the flow. This type of control is well known globally and is effective as far as the straight linear line will allow. For more realistic HVAC control with superior energy savings, consider the following control recommendation 5.4 Quadratic Curve Control.

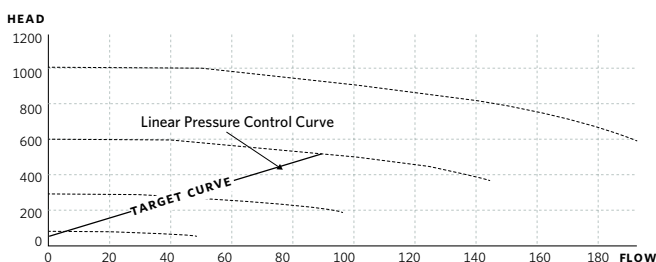

### 5.4 QUADRATIC CURVE CONTROL

Quadratic Pressure Control is where the controller is set to control the speed according to a control curve between max and min flow. It is widely recognised that fitting a differential pressure sensor at the most remote load, across the supply piping and return piping encompassing the valve and coil set, is the benchmark scheme for energy efficiency.

Design Envelope pumps can replicate this control without the need for the remote sensor. As the flow required by the system is reduced, the pump automatically reduces the head developed according to the pre-set control curve.

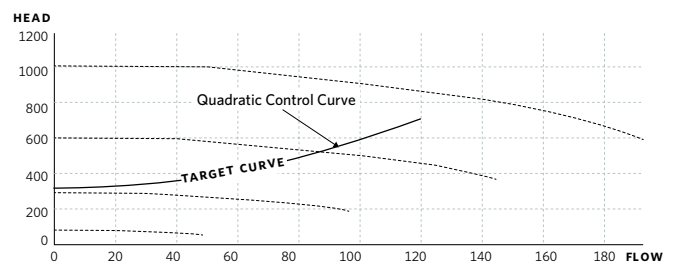

### 5.5 QUADRATIC CURVE CONTROL WITH MINIMUM FLOW PROTECTION

This configuration is designed for HVAC hydronic systems where flow sensitive equipment required a minimum flow for equipment stability; such as a chiller that cannot tolerate flow below a certain volume. This control will take advantage of the 5.4 Quadratic Curve Control mode, where the pump will increase speed to maintain a minimum flow setting as the system load is shutting down.

Pump controls can only control the flow to the maximum speed or motor limit;

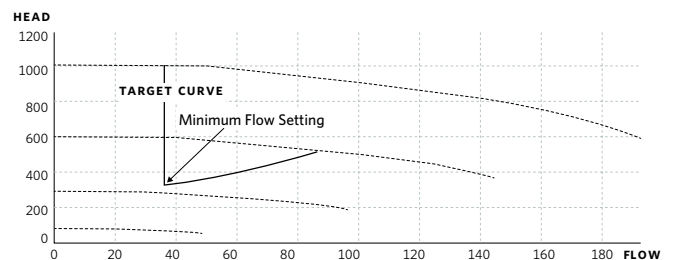

### 5.6 QUADRATIC CURVE CONTROL WITH MAXIMUM FLOW PROTECTION

This configuration is ideal for HVAC hydronic systems where pumps are generally oversized and a flow limit is required for system equipment stability and resulting energy savings. This control will take advantage of the 5.4 Quadratic Curve Control mode, where the pump will decrease speed to maintain a maximum flow setting. This will prevent over-pumping and save energy costs. Over-pumping is common in HVAC

systems as pumps are typically oversized for the application. Pump controls can only control the flow to a minimum speed; thus a dry-contact relay is supplies which will close when maximum flow is reached, which can be used for an alarm or other device.

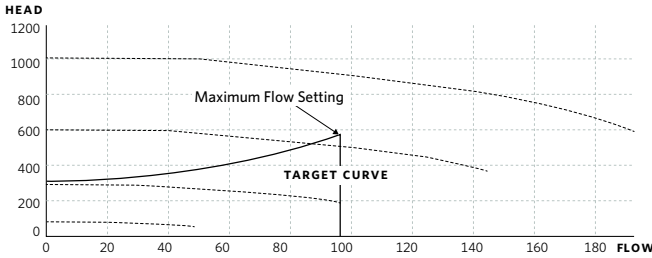

**5.7 QUADRATIC CURVE CONTROL WITH MINIMUM & MAXIMUM FLOW PROTECTION**

This control mode combines the control logic of 5.5 & 5.6 which takes the values of the quadratic control curve and protection for both the maximum & minimum flow limits. Pump controls can only control the flow to the motor limit or maximum / minimum speed limits of the unit, thus a dry-contact relay is supplies which will close when either the minimum or maximum flow is reached, which can be used for an alarm or other device.

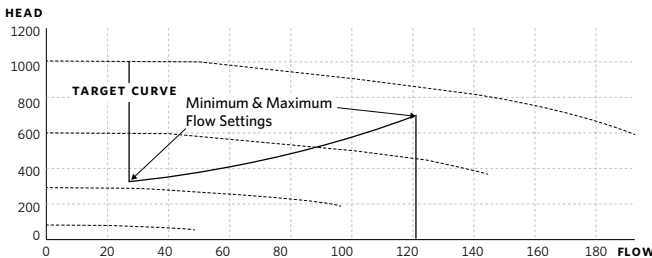

**5.8 PARALLEL SENSORLESS PUMP CONTROL (PSPC)**

This configuration maps the quadratic control curve into the pump controls and ensures the system flow requirements are met, while staging the pumps on and off to maintain optimum pump energy usage. This is accomplished by operating the pumping units at the best pumping efficiency level for the required flow.

This control is available for 2, 3, or 4 Design Envelope pump units operating in parallel. Tango and dualArm units have Parallel Sensorless Pump Control (PSPC) pre-programmed in the controls at Armstrong factories. For all other models (except twin pumps), PSPC can be enabled aftermarket; please contact your local Armstrong factory for details.

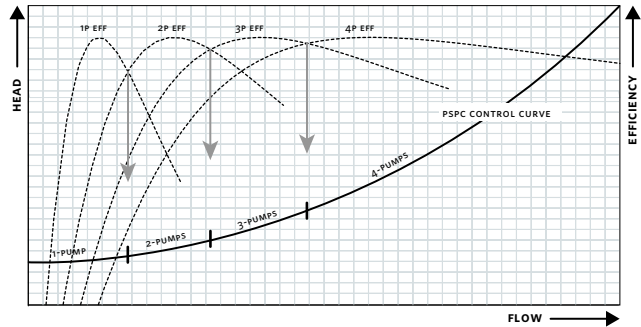

Both individual pumps and total parallel flow can be monitored by accessing **Settings -> Pump -> Control Mode -> Parallel Sensorless**

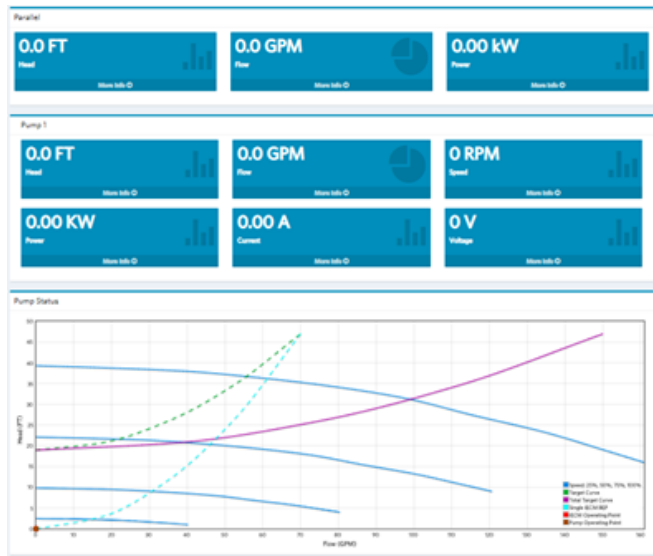

**5.8.1 EMBEDDED PARALLEL SENSORLESS PUMP CONTROL FOR MULTIPLE PUMPS**

If the Parallel Sensorless Pump Control option was purchased for control of 2, 3 or 4 single pumps (VILs and End Suctions) the function can be enabled at any time. Note that pumps must be of the same model for parallel operation.

Start by installing a wiring bridge between the pumps (supplied by others). The wiring between the control cards is a CANBUS (3-wire) cable with terminal blocks at each end (3 position strain 3.81 mm).

For connection of 3 or 4 pumps, the CANBUS connectors should be daisy-chained together.

Wiring bridge supplied by others.

**For 2 pump parallel operation:**

Ensure that both terminating resistor switches are set to Enabled (towards the **EN** label for the CANBUS port).

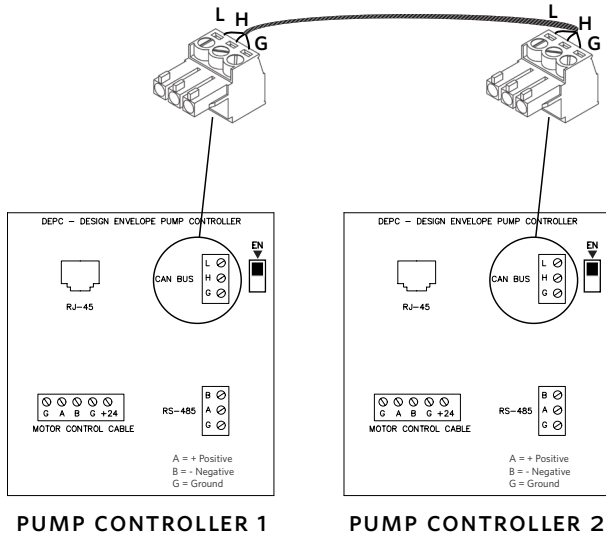

**For 3 or 4 pump parallel operation:**

Ensure that only the first and last terminating resistor switches are set to Enabled (towards the **EN** label for the CANBUS port).

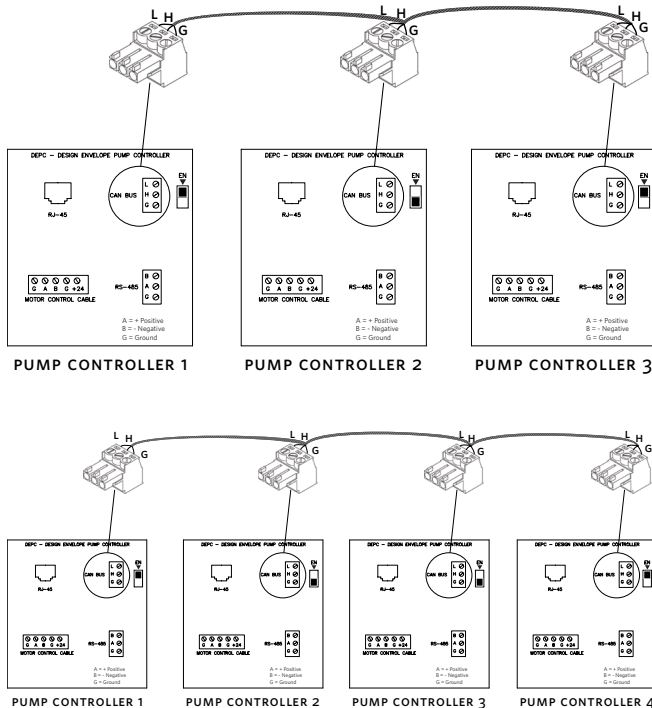

From the Webserver, choose **Settings -> Pump**, set control mode to Parallel with the following parameter values:

**Control Mode**

Parallel Inputs Automatic Remote

Options:

**A** Id: 1  
Flow BEP: 85  
Head BEP: 80  
**B** Dead Band: 0.25  
**C** Total Design Flow: 171.4  
Stage On Speed Percent: 0  
Stage Off Speed Percent: 0  
**D** Sensorless Map Adjust Factor: 0.1  
Alternation Interval (minutes): 10080  
**E** Minimum On Time (Seconds): 15

- A** ID: 1 to 8, the lower number is the lead pump e.g. enter 1 for lead pump, 2 for lag pump
- B** Dead Band: set to 0.25
- C** Total Design Flow: enter the parallel flow rate
- D** Sensorless Map Adjust Factor: set to 0.1
- E** Minimum On Time (seconds): set to 15

Click **UPDATE** to save all changes. Connect the Webserver to the second pump and then repeat above steps **A** to **E**.

**5.8.2 MODIFYING MOTOR RAMP UP AND DOWN TIME**

Modify the time in the respective fields after clicking on **Pump** under **Settings**

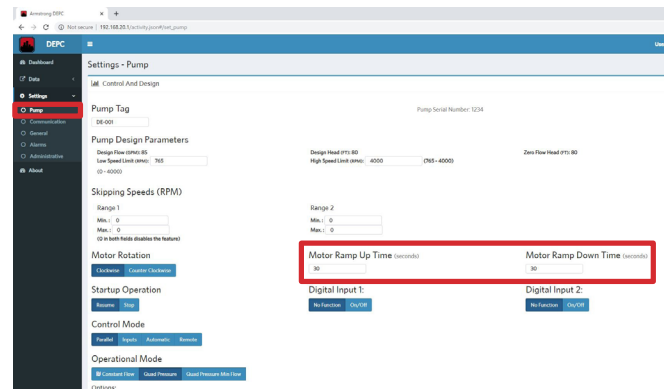

### 5.8.3 THREE DIFFERENT CONTROL MODES CAN BE ACCESSED

Constant Flow, Quadratic Pressure and Quadratic Pressure with Minimum Flow.

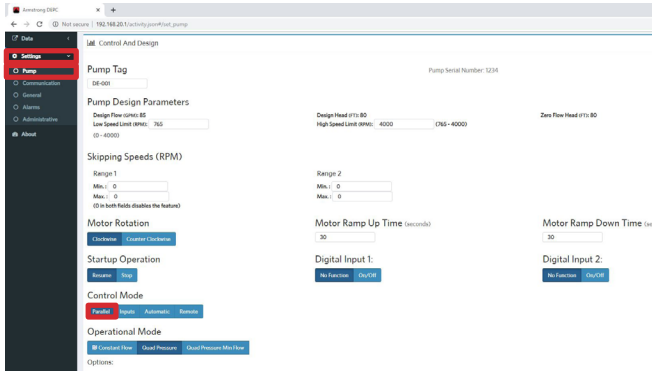

### 5.8.4 FALLBACK PERCENTAGE OF MAXIMUM SPEED

While operating multiple pumps in Parallel Sensorless mode, if any of the pumps are disconnected from the communication circuit (e.g. the pump is disconnected from the CANbus wire), the disconnected pump will now continue to operate at a pre-set constant speed – or the fallback speed. The fallback speed can be set to a percentage of the pump’s maximum speed (between 40-100%).

Note that only the disconnected pump will operate at constant speed, the other remaining pumps in the communication circuit will continue to operate in Parallel Sensorless mode to the control curve.

This can be done in **Operational Mode** and input the **Fallback % of Max Speed**

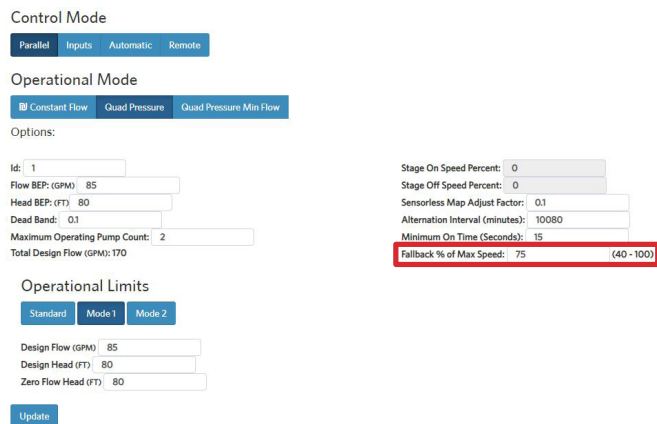

### 5.8.5 STANDBY PUMPS

Scroll down to **Operational Mode** and input the **Maximum Operating Pump Count**. The remaining pumps will be Standby. Calculated Design Flow will automatically update based on the number of pumps inputted.

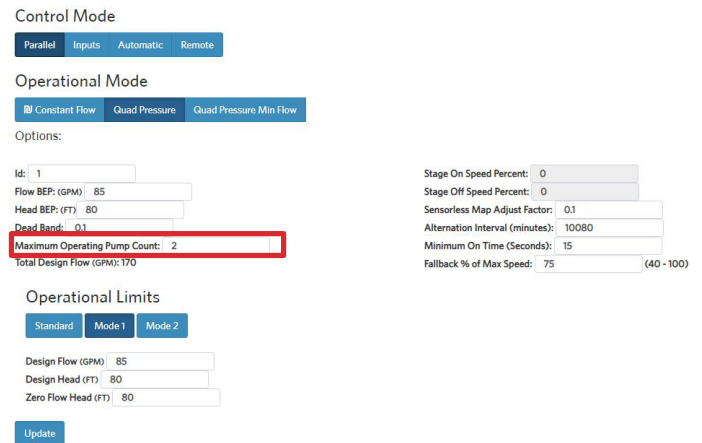

### 5.9 2\*100% CAPACITY SPLIT UNITS

When duty / standby is specified, enter the total system flow into ACE Online or ADEPT, then select 2\*100% unit split for a superior customer value. The 100% flow redundancy is still in place **plus** the onboard PSpC will engage the second unit in parallel operation should it predict lower operating costs.

If second side power is locked out, the operating pump will operate alone on the control curve to 100% design flow.

### 5.10 ALTERNATION

Design Envelope Tango, dualARM, and Twin units are pre-set to alternate lead-pump operation of each pump head to achieve equal run hours. The default alternation interval is 10,080 minutes (1 week). This can also be set or adjusted for multiple single pumps operating in sequence.

To change this setting, use the Webserver and go to Settings -> Pump, and then go the Control Mode section, under the Parallel tab, and input the Alternation Interval (in minutes) to the new value. Press UPDATE to complete the change. Connect the Webserver to the second pump and repeat.



## Control Mode

Parallel Inputs Automatic Remote

Options:

Id: <input type="text" value="1"/> Flow BEP: <input type="text" value="85"/> Head BEP: <input type="text" value="80"/> Dead Band: <input type="text" value="0.25"/> Total Design Flow: <input type="text" value="171.4"/>	Stage On Speed Percent: <input type="text" value="0"/> Stage Off Speed Percent: <input type="text" value="0"/> Sensorless Map Adjust Factor: <input type="text" value="0.1"/> Alternation Interval (minutes): <input type="text" value="10080"/> Minimum On Time (Seconds): <input type="text" value="15"/>
---	---

### 5.11 CONSTANT PRESSURE CONTROL

Can be achieved if **Design Head** and **Zero Flow Head** are set to same value

Control Mode  
Parallel Inputs Automatic Remote

Operational Mode  
Constant Flow Quad Pressure Quad Pressure Min Flow

Options:

Id: <input type="text" value="1"/> Flow BEP (GPM): <input type="text" value="85"/> Head BEP (FT): <input type="text" value="80"/> Dead Band: <input type="text" value="0.1"/> Maximum Operating Pump Count: <input type="text" value="2"/> Total Design Flow (GPM): <input type="text" value="170"/>	Stage On Speed Percent: <input type="text" value="0"/> Stage Off Speed Percent: <input type="text" value="0"/> Sensorless Map Adjust Factor: <input type="text" value="0.1"/> Alternation Interval (minutes): <input type="text" value="10080"/> Minimum On Time (Seconds): <input type="text" value="15"/> Fallback % of Max Speed: <input type="text" value="75"/> (40 - 100)
---	--

Operational Limits  
Standard Mode 1 Mode 2

Design Flow (GPM):   
 Design Head (FT):   
 Zero Flow Head (FT):

Update

### 5.12 DUAL SEASON SETUP

Design Flow, Head and Zero Flow Head in Mode 1 and Mode 2 can be used as the two seasons of a Dual Season Setup

Operational Mode  
Constant Flow Quad Pressure Quad Pressure Min Flow

Options:

Id: <input type="text" value="1"/> Flow BEP (GPM): <input type="text" value="85"/> Head BEP (FT): <input type="text" value="80"/> Dead Band: <input type="text" value="0.1"/> Maximum Operating Pump Count: <input type="text" value="2"/> Total Design Flow (GPM): <input type="text" value="170"/>	Stage On Speed Percent: <input type="text" value="0"/> Stage Off Speed Percent: <input type="text" value="0"/> Sensorless Map Adjust Factor: <input type="text" value="0.1"/> Alternation Interval (minutes): <input type="text" value="10080"/> Minimum On Time (Seconds): <input type="text" value="15"/> Fallback % of Max Speed: <input type="text" value="75"/>
---	---

Operational Limits  
Standard Mode 1 Mode 2

Design Flow (GPM):   
 Design Head (FT):   
 Zero Flow Head (FT):

Update

## 5.13 SENSORED CONTROL

dP sensors can be added to a single pump or a parallel pumping system through either the LCD Screen on the Pump or the Webservice.

### 5.13.1 ADDING DP SENSORS THROUGH LCD SCREEN

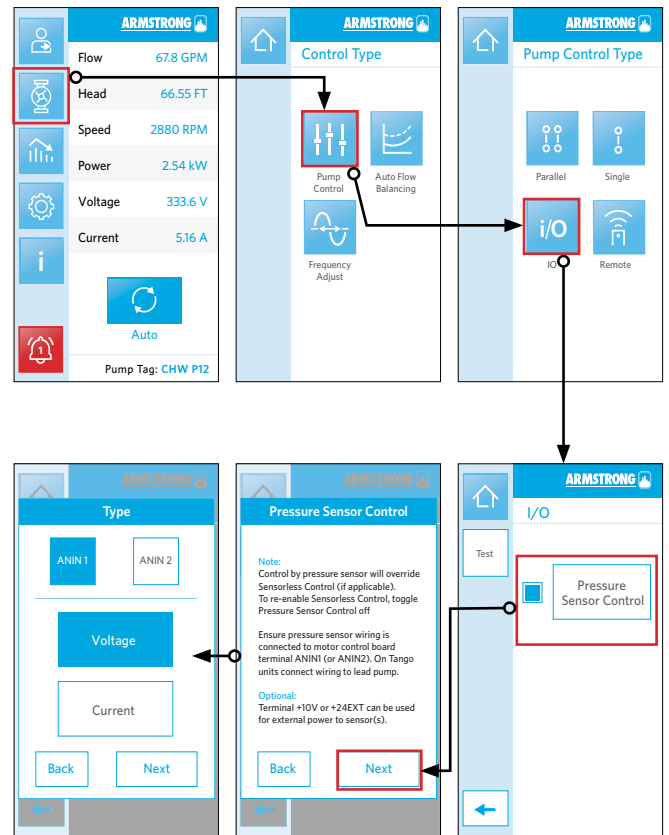

### 5.13.2 ADDING DP SENSORS FROM WEBSERVER

Scroll down to **Control Mode: Inputs**

Control Mode  
Parallel **Inputs** Automatic Remote

Analog In 1 Configuration:  
No Function **Speed** Pressure Current Voltage

Analog In 2 Configuration:  
No Function Speed Pressure Current Voltage

Min(mA): 4 mA  
 Max(mA): 20 mA  
 Min Speed(rpm): 765  
 Max Speed(rpm): 4000

Update

### 5.14 BYPASS VALVE CONTROL

The bypass valve control is used to protect flow sensitive equipment (such as chillers). If the flow is less than Setpoint 1, the DEPC analog output sends 20mA to fully open the valve. If the flow is greater than Setpoint 2, the DEPC analog output sends 4mA to fully close the valve. There should be a sufficient gap between Setpoint 1 and 2 Flows to prevent the bypass valve from opening and closing unnecessarily. The recommended bypass valve is a modulating non-spring return valve (normally closed) with either 4-20mA analog input, or 2-10 Vdc analog input (requires adding 500 ohm resistor across the valve input).

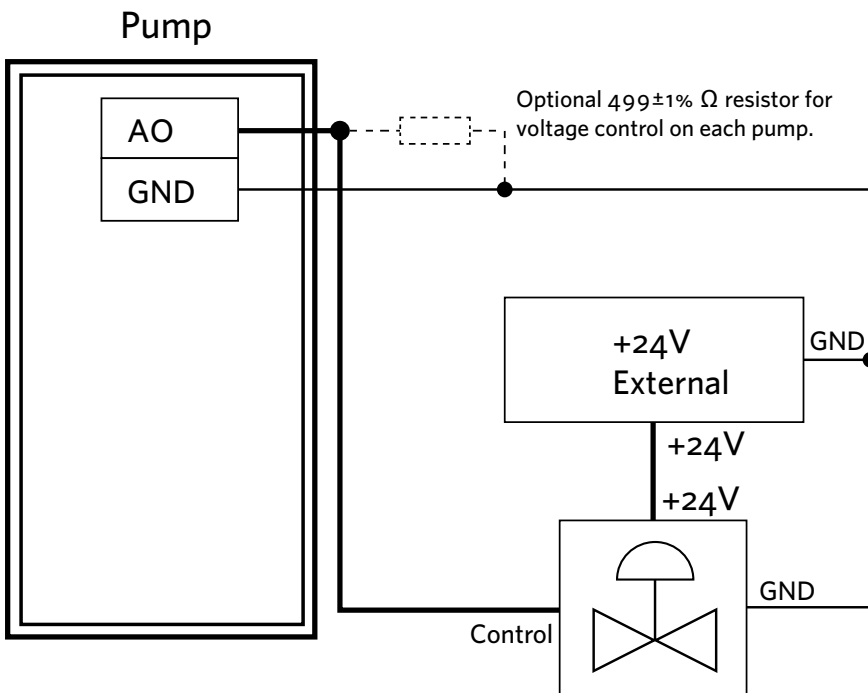
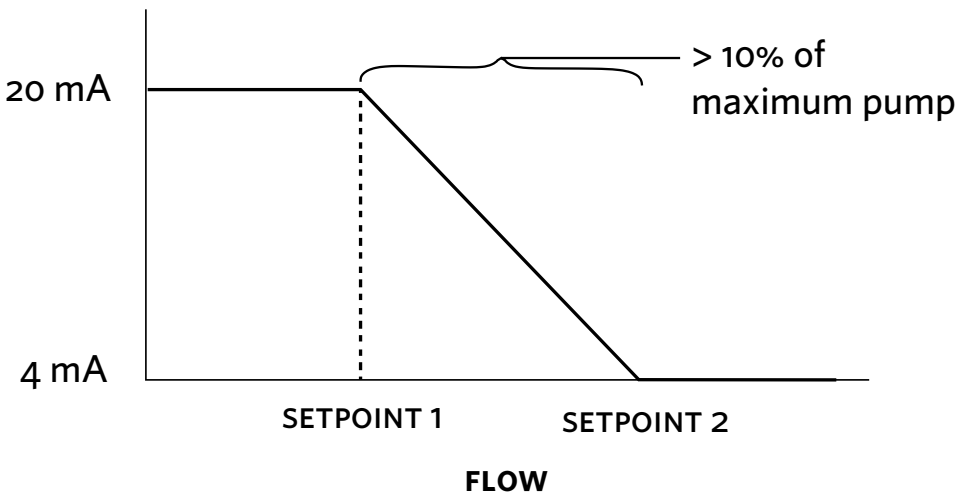



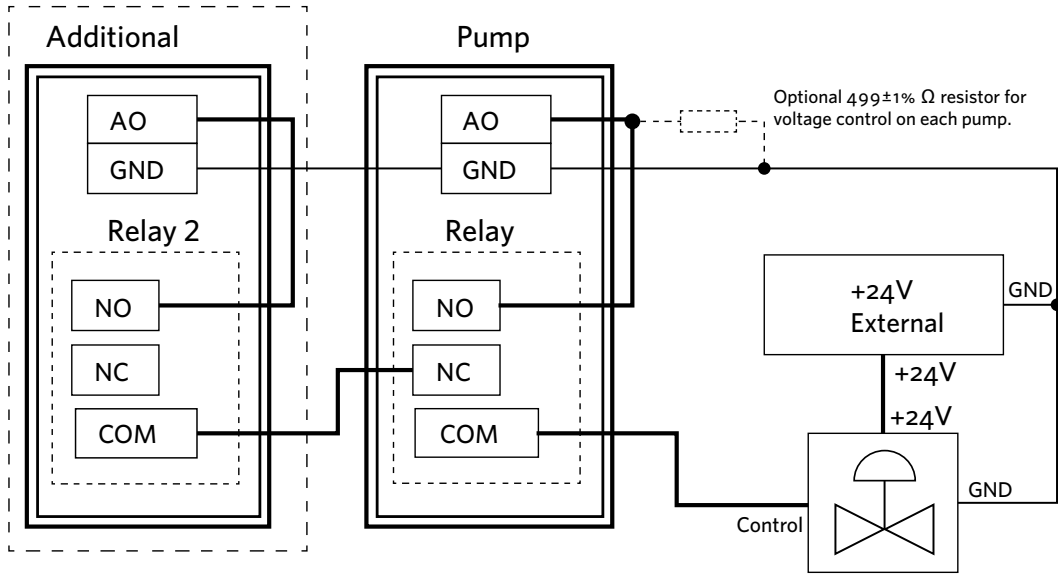

Outputs

Digital Functions:  Enabled  Disabled

Digital Output 1

Digital Output 2

Analog Functions:  Enabled  Disabled

Analog Output

Low Flow Threshold:  GPM

High Flow Threshold:  GPM

Note: The minimum difference between High and Low Flow Threshold should be atleast 20 GPM

Relay Functions:  Enabled  Disabled

Relay 1

Relay 2

Outputs

Digital Functions:  Enabled  Disabled

Digital Output 1

Digital Output 2

Analog Functions:  Enabled  Disabled

Analog Output

Low Flow Threshold:  GPM

High Flow Threshold:  GPM

Default Valve position:  %

Note: The minimum difference between High and Low Flow Threshold should be atleast 20 GPM

Relay Functions:  Enabled  Disabled

Relay 1

Relay 2

## 6.0 MAINTENANCE

### 6.1 GENERAL CARE

Vertical In-Line pumps are built to operate without periodic maintenance, other than motor lubrication on larger units. A systematic inspection made at regular intervals, will ensure years of trouble-free operation, giving special attention to the following:

- Keep unit clean
- Provide the motor with correctly sized overload protection. Keep moisture, refuse, dust or other loose particles away from the pump and ventilation openings of the motor.
- Avoid operating the unit in overheated surroundings (Above 100°F/40°C).

#### WARNING



Whenever any service work is to be performed on a pumping unit, disconnect the power source to the driver, lock it off and tag with the reason. Any possibility of the unit starting while being serviced must be eliminated. If mechanical seal environmental accessories are installed, ensure water is flowing through the sight flow indicator and that filter cartridges are replaced as recommended. (See Armstrong files 43.85 and 43.86 for seal environmental instructions).

### 6.2 LUBRICATION

#### Pump

Lubrication is not required. There are no bearings in the pump that need external lubrication service.

Large Design Envelope 4300 units are installed with a shaft bushing located beneath the impeller that is lubricated from the pump discharge.

#### Motor

Follow the lubrication procedures recommended by the motor manufacturer. Many small and medium sized motors are permanently lubricated and do not require additional lubrication. In general, motors that have grease fittings will require periodic lubrication.

Check the lubrication instructions supplied with the motor for the particular frame size indicated on the motor nameplate.

### 6.3 MECHANICAL SEAL

Mechanical seals require no special attention. The mechanical seal is fitted with a flush line. The seal is flushed from the discharge of the pump casing on Design Envelope 4300 pumps, and from the suction on Design Envelope 4380 pumps.

The Design Envelope 4300 pump is flushed from the pump discharge because the mechanical seal chamber is isolated from the liquid in the pump by a throttle bushing. With the seal chamber being isolated, seal environmental controls such as filters and separators are very effective when installed in the Design Envelope 4300 flush line, as only the seal chamber requires cleaning. This arrangement will also help prolong the life of the seal in HVAC systems.

Do not run the pump unless properly filled with water as the mechanical seals need a film of liquid between the faces for proper operation.

Mechanical seals may weep slightly at start-up. Prior to calling for service, allow the pump to operate continuously for a few hours as the mechanical seal becomes properly seated.

#### WARNING



Hydronic system components may be pressurized. Any actions that result in the sudden release of this pressure could result in serious injury, or death. Prior to performing any service work on a pump, the pressure should be carefully relieved, and the system shall be properly drained.

#### 6.3.1 MECHANICAL SEAL REPLACEMENT INSTRUCTIONS FOR RIGID SPLIT-COUPLED PUMPING UNITS (SERIES 4300 & 4322)

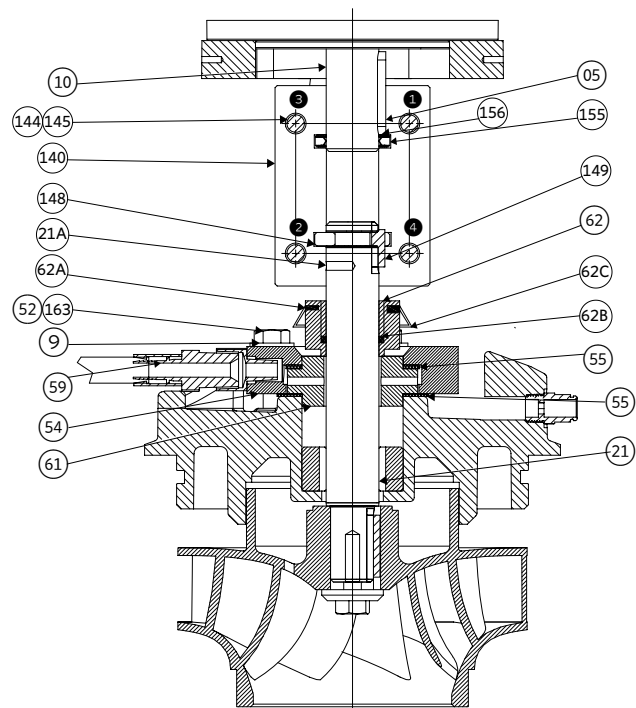

#### WARNING



When reinstalling the clamp, tighten the clamp nut to 90-100 in-lb torque.

## CAUTION



Do not use oil, Vaseline or other petroleum or silicon based products for seal elastomer lubrication. Doing so may result in elastomer swelling and seal failure. Recommended: International Products Corp p-80 Rubber Lubricant Emulsion in USA & UK [www.ipcol.com](http://www.ipcol.com)

## Seal Removal



An important feature of the rigid split-coupled pump is that the design permits removal of the mechanical seal without disturbing the pump, motor or electrical wiring.

- A** Disconnect the power supply at the main switch and close the isolating valves on the suction and discharge. Empty casing by removing drain plug(s) located at the bottom.
- B** Loosen off the seal collar set screws (62A), remove the coupling screws and lock washer (144,145), and separate the coupling halves (140). Remove the motor shaft key (05) and the pump shaft key (149).  
Do not remove motor collar (155) for seal replacement.
- C** Remove the mechanical seal rotating assembly (62) through the gap between the pump and motor shafts..
- D** Disconnect the seal flush piping (59) from pump discharge. Mark seal gland plate (54) position. Remove the seal gland plate bolts and washer (lock washer) (52,163), and the seal gland plate (54). Remove the stationary seat (61) and seat gaskets (55).

## Seal replacement

Handle mechanical seal carefully to protect seal faces from damage. Do not contaminate seal faces with finger prints

- E** Replace the stationary seat (61) and gaskets (55) from mechanical seal package, aligning the seat flush hole with the seal gland plate flush line connection. Ensure the large diameter gasket is on the bottom. Replace seal gland plate (54) and tighten the seal gland plate bolts (52,163) evenly and diagonally to 5 (ft. lbs) for 0.75" seal size.
- F** When installing the mechanical seal (62), ensure parts are perfectly clean.
- G** Apply a small amount of temporary rubber lubricant emulsion to the O-ring (62B). Carefully slide the mechanical seal rotating assembly (62) down the shaft onto the stationary seat (61). Do not tighten the set screws (62A) on the side of the mechanical seal yet. Do not remove holding clips (62C).

**If motor is replaced:** Loosen set screws (56) on motor shaft collar (155) and remove from old motor shaft. To position the collar (155) correctly on the new motor shaft, temporarily fit motor shaft collar (155) into groove of the keyed coupling half. Slide collar, with coupling half onto new motor shaft until end of shaft lines up with line scored into coupling. Tighten the visible set screws (156) in the collar (155) such that its held in place on the shaft, and then remove the coupling half. Tighten all collar set screws (156) evenly and diagonally.

- H** Fit the motor shaft key (05) and the pump shaft key (149), and then install the keyed coupling half (140) first.

## NOTE:

For easier coupling installation, motor and pump shaft keys (05 & 149) should be 180 degrees from the working area. To automatically locate the impeller in the pump, insert the coupling screw Allan wrench into positioning hole (21A) and lift pump shaft until the pump shaft collar is positioned in the coupling groove, then rotate shaft to locate the pump shaft key (149) into blind keyway in coupling.

- I** Place the second coupling half into position and tighten the coupling screws (144,145) following the tightening pattern shown on the illustration (1-2-3-4).

## NOTE:

Snug fit the coupling screws and confirm even gap spacing between coupling halves, then firmly tighten coupling screws following the tightening pattern illustrated. Push (or slide) mechanical seal (62) firmly onto the stationary seat (61) and tighten the set screws (62A) with a torque wrench to 5 (ft. lbs). The mechanical seal is now pre-set at the correct working length.

- J** Replace the seal flush piping (59) and drain plug(s). Open all isolating valves prior to operating pump(s). Reconnect power supply.

**6.3.2 MECHANICAL SEAL REPLACEMENT  
INSTRUCTIONS FOR CLOSE-COUPLED PUMPING  
UNITS (SERIES 4380 & 4372)**

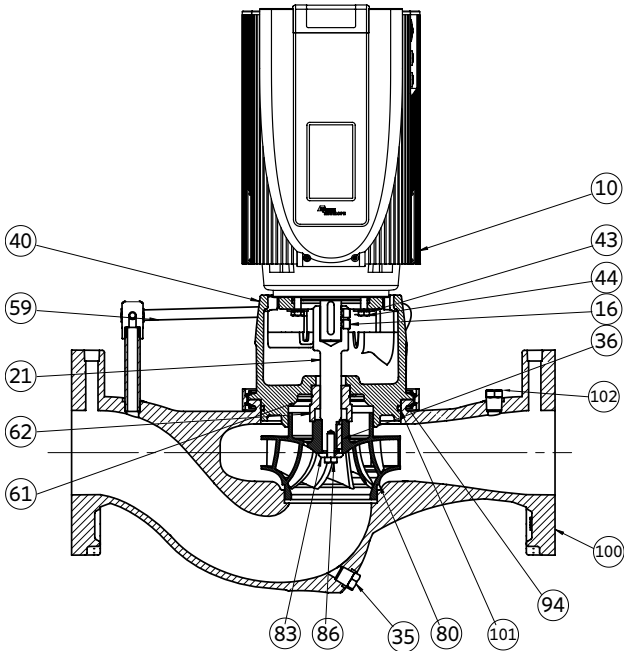

The close-coupled or motor mounted type Vertical In-Line pumps use vertical shaft-down ball bearing motors (integrated motors and drives). Each pump and motor unit is pipe mounted and, as such, relies only on the piping for its support. The piping support is designed for the weight of the piping, liquid, pump and motor, as well as other pipe fittings. The pumping unit should not be independently secured to the building structure. If the pump is mounted separately to any structure, the pump must be isolated from the piping with flexible piping connections. For units with larger motors it is advisable to install a permanent device for lifting the rotating assembly out of the pipe mounted casing to service the unit.

**Breakdown procedures:**

**CAUTION**



Exercise extreme care when handling power wiring. Ensure that the fuses are removed or breaker disconnected in the power line to the motor. Power disconnect should be within sight of the pump being serviced and tagged with the reason for disconnection.

**A Electrical wiring**

If the pump and/or motor assembly is to be serviced on a bench, the motor wiring must be disconnected.

**B Isolation valves**

If the system is not drained: Ensure that the suction and discharge piping isolation valves are closed. Remove drain plug (35) from the bottom of the casing and drain the pump.

**C Prepare assembly for removal**

Secure the motor (10) by lifting straps to an overhead chain fall or similar lifting device. The device must be designed to lift the weight of the unit safely. Raise the lifter to bring the lifting straps taut. Disconnect the flush/vent flex hose from pump suction and secure flex hose to one side. Remove the clamp ring between casing (100) and adapter (40). Care should be taken not to apply pressure to the outside diameter of the adapter; to prevent possible breakage, outside pressure should be on the casing only.

**D Remove rotating assembly**

The rotating assembly [motor, adapter and impeller] (10, 40 & 80) may now be lifted out of the casing.

**E Rotating assembly notes**

The impeller (80) is fastened directly to the stub shaft and must be removed to replace the mechanical seal assembly (61/62). This may be accomplished on a safe surface near the installation, or more conveniently on a work bench.

**F Impeller cap screw**

The impeller (80) should be prevented from rotating while the impeller cap screw (86) is loosened. A heavy screwdriver or pry bar may be inserted in between the impeller blades to enable the impeller cap screw (86) to be backed off with a socket wrench [NOTE: be careful not to damage the impeller blades]. Remove the impeller cap screw and washer (86 & 83).

**G Pump impeller**

Using wheel pullers, with the jaws behind the rear shroud of the impeller (80) [behind a vane at each side] pull the impeller free of the pump shaft. An impeller that is difficult to remove may be loosened by heating the impeller hub with a torch while pulling the impeller from the motor shaft.

**H Remove mechanical seal from motor shaft**

The mechanical seal spring usually comes free with the impeller. The mechanical seal rotating element [seal head] (62) must be pried loose with pry bars or screwdrivers, placed under each side of the seal drive band. Leverage is applied against the adapter. Once loosened, the seal may be pulled free of the shaft.

Do not damage the carbon face when removing the rotating element [seal head]. It may be needed for analysis if seal failure investigation is required.

**I Remove seal seat from adapter**

The stationary seat (61), typically O-ring or L-cup mounted Silicon Carbide material, is pried loose from the recess in the adapter. If the seat cannot be removed in this manner, remove the motor cap screws and washers [lock washers] (43, 44) and separate the adapter (40) from the motor (10). A screwdriver may then be used to push the seat out of the adapter from the rear.

**J Remove old casing gasket**

The former adapter O-ring should be scraped from the adapter, leaving clean surfaces [groove] for the new O-ring. [A standard putty knife and wire brush are useful for this purpose].

**K Assembly Procedures:****Replace mechanical seal**

- Clean the shaft stub (21) surface, ensuring all the former seal elastomer pieces have been removed. Inspect for damage. Replace if necessary.
- Install a new stationary seat (61) in the adapter cavity, being sure the lapped (polished) side of the insert is facing up. Ensure that the cavity has been thoroughly cleaned. Lubricate the stationary seat O-ring or L-cup with a small amount silicon or glycerine lubricant and firmly press down straight and even into the adapter cavity. Do not press the seat in with bare fingers or hammer it down, use a clean cloth or the cardboard disc typically supplied with the seal packaging. Contamination of the polished and lapped stationary seat face could cause leakage. If the adapter was removed from the motor, ensure that the stationary seat is carefully guided over the stub shaft when the adapter is being reinstalled.
- Lubricate the inside of the rotating seal [seal head] (62) with a small amount of silicon or glycerine lubricant and slide onto the stub shaft (21) with a twisting motion, carbon face first, until the carbon face is pressed firmly against the stationary seat (61). Firmly press on the rotating seal [seal head] metal parts with a screw driver all the way around the seal which will ensure that the faces are mated properly. Remove the spring retainer from the seal spring and place the seal spring over the rotating seal.

**L Replace pump impeller**

- Install the impeller key on the shaft and place the seal spring retainer onto the impeller hub register. Slide the impeller in place on the stub shaft.
- Take care and ensure that the seal spring is kept in place on the seal rotating assembly and fits well into the retainer on the impeller hub.

**M Tighten impeller cap screw**

It is good practice to replace self locking screws, once removed. Install the impeller cap screw and washer (83 & 86). Hold the impeller the same way as when the cap screw was successfully loosened (pry bar or screw driver placed carefully between the impeller blades) and tighten the cap screw with a socket wrench.

**P Install new adapter O-ring**

Insert the O-ring into the associated groove on the adapter and apply silicon or glycerine lubricant around the O-ring.

**Q Clamp-Ring**

Insert clamp-ring through the impeller and adapter flange. Tighten the nut on the clamp ring to 90-100 lbs-in.

**R Lower rotating assembly into place**

The rotating assembly [motor, adapter and impeller] may now be lowered into the casing.

**S Casing and adapter clamp-ring**

The casing and adapter clamp-ring is now installed and tightened with a wrench.

Reconnect the flush/vent flex hose assembly [check for damage and replace if necessary].

**T Isolation valves**

Replace the casing drain plug and open the suction and discharge isolation valves.

**Motor wiring**

- The motor conduit and its wiring are now replaced. If the motor is new, double check that the voltage and rpm are identical to the original motor.
- If replacing a three-phase motor, check for proper rotation after rewiring. If necessary, switch any two lead wires to change the direction of rotation.
- Before operating the pump (e.g. to check rotation), ensure that it is filled with water.

**U Conduit Box Cover**

The conduit box cover shall be replaced after the motor's rotation has been confirmed. The pump may now be placed into operation.

## 6.4 SYSTEM CLEANLINESS

Before starting the pump, the system must be thoroughly cleaned, flushed, drained, and then replenished with clean liquid.

Welding slag and other foreign materials, Stop Leak and cleaning compounds, and improper or excessive water treatment are all detrimental to the internal components, and sealing arrangement of the pump.

Proper operation cannot be guaranteed if the above conditions are not adhered to.

## 7.0 WARNINGS AND ALARMS

### 7.1 ALARM SUMMARY FOR INTERFACES

ALARM NUMBER	NAME	ALARM DESCRIPTION
1	vSD over temperature	The temperature of a vSD or motor component is exceeding the thermal alarm limit. Turn off the power to the pump and verify that the motor, fan and vSD cooling is functioning correctly. Verify that the pump is not overloaded. Wait until hot components have cooled before returning to service and if the alarm persists after powering up contact an Armstrong Technical Service representative.
2	vSD over current	The vSD has detected current exceeding the safe limit. Turn the pump off. (If there is a discharge from the output phases to earth it can be verified by checking for any faults with a megohmmeter between ground and the motor leads). If a current limit has been exceeded in the vSD check that the motor can be turned. If the pump is being overloaded reduce the pump speed using hand mode control. If the alarm persists after powering up contact an Armstrong Technical Service representative.
3	External vSD voltage	The voltage into the vSD is out of range. Verify that the correct voltage required to operate the vSD is present by measuring each of the 3 phases. If the alarm persists after cycling power to the pump, contact an Armstrong Technical Service representative.
4	Internal vSD voltage	An internal voltage generated by vSD is out of range. If the alarm persists after cycling power to the pump, contact an Armstrong Technical Service representative.
5	Internal vSD	An internal error in the vSD has occurred. If the alarm persists after cycling power to the pump, contact an Armstrong Technical Service representative.
6	vSD parameter	One or more of the parameters to control the vSD are not correct. Check the settings on the control card. If the alarm persists after cycling power to the pump, contact an Armstrong Technical Service representative.
7	vSD startup	An error occurred during the startup of the motor. Turn off the power to the pump and verify that the motor can be turned by using hand mode control. If the alarm persists after powering up contact an Armstrong Technical Service representative.
8	Other vSD	There has been an unknown alarm condition generated by the vSD. If the alarm persists after cycling power to the pump, contact an Armstrong Technical Service representative.
9	vSD communication	There is a communication issue between the control card and vSD. Turn off the power to the pump and check the connections between the control card and the vSD.
10	vSD speed	The speed set by the vSD is not within tolerance. If the alarm persists after cycling power to the pump, contact an Armstrong Technical Service representative.
11	vSD initialization failure	The control card was not able to receive the initial parameters correctly. Please try to restart the pump. If the alarm persists after restart, contact an Armstrong Technical Service representative.

## 7.2 WARNING SUMMARY FOR INTERFACES

WARNING NUMBER	NAME	WARNING DESCRIPTION
1	vsd over temperature	The temperature of a vsd or motor component is near the thermal warning limit. Check that the motor, fan and vsd cooling is functioning correctly. Verify that the pump is not overloaded. If the warning persists, contact an Armstrong Technical Service representative.
2	vsd over current	The vsd has detected current exceeding the warning limit. Turn the pump off. (If there is a discharge from the output phases to earth it can be verified by checking for any faults with a megohmmeter between ground and the motor leads.) If a current limit has been exceeded in the vsd check that the motor can be turned. If the pump is being overloaded reduce the pump speed using hand mode control. If the warning persists after powering up contact an Armstrong Technical Service representative.
3	External vsd voltage	The voltage into the vsd is out of range. Verify that the correct voltage required to operate the vsd is present by measuring each of the 3 phases. If the warning persists, contact an Armstrong Technical Service representative.
4	Internal vsd voltage	An internal voltage generated by vsd is out of range. If the warning persists, contact an Armstrong Technical Service representative.
5	Internal vsd	An internal warning in the vsd has occurred. If the warning persists, contact an Armstrong Technical Service representative.
6	Reserved	
7	vsd startup	A warning occurred during the startup of the motor. Turn off the power to the pump and verify that the motor can be turned using hand mode control. If the warning persists after powering up contact an Armstrong Technical Service representative.
8	Other vsd	There has been an unknown warning condition generated by the vsd. If the alarm persists, contact an Armstrong Technical Service representative.
9	vsd communication	There is a communication issue between the control card and vsd.
10	vsd speed	The speed set by the vsd is not within tolerance. If the alarm persists, contact an Armstrong Technical Service representative.
11	vsd wiring	There is an issue in wiring to the vsd. Check the wiring to the motor from the vsd. If any I/O are used on the vsd, verify that there is continuity and no shorts for the connections.
12	System over temperature	The temperature measured by the control card is approaching the recommended operating conditions.
13	System under temperature	The temperature measured by the control card is approaching the recommended operating conditions.
14	Battery under voltage	The battery voltage is low. Replace the battery with CR2032 type cell.
15	BMS communication loss	BMS communication has been lost.
16	vsd communication loss	The communication with the vsd and the control card has stopped.
17	Invalid vsd parameter	The control card has specified an invalid vsd parameter.
18	vsd initialization failure	The initialization of the vsd through Modbus has failed. Cycle power to the pump to re-initialize.
19	vsd speed set failure	The speed could not be set by the controller. Check the connections between the vsd and control card.
20	vsd start set failure	The controller could not start the motor. Check the connections between the vsd and control card.
21	Sensorless error	The sensorless map that was entered has an error please refer to the I & O Manual for further details.
22	Hand mode timeout	The pump has been in hand mode too long. Consider setting to automatic mode to save energy.

### 8.0 FUSE AND WIRE RECOMMENDATION

Armstrong recommends UL 508 listed fast-acting, current-limiting fuses for upstream protection of installations within the NEC/UL jurisdiction.

Example fuses suitable for upstream protection are detailed below.

#### ARMSTRONG DISCONNECT SWITCH AND FUSE RATING - 1PH 200-240V INPUT POWER FOR USE WITH DESIGN ENVELOPE PERMANENT MAGNET MOTORS - FRAME 71

RATED POWER		DISCONNECT SWITCH RATING	FUSE RATING	FUSE CLASS TYPES	MAXIMUM DRIVER INPUT CURRENT (A)	
HP	KW				200 VAC	240 VAC
0.33	0.25	30A	6A	CC FAST-ACTING	2.0	1.6
0.5	0.37		6A		2.6	2.0
0.75	0.55		10A	J FAST-ACTING	3.3	2.9
1	0.75		10A		4.8	4.0
1.5	1.1		15A	RK1 FAST-ACTING	7.1	5.8
2	1.5		20A		9.3	7.6

#### ARMSTRONG DISCONNECT SWITCH AND FUSE RATING - 3PH 200-240V INPUT POWER FOR USE WITH DESIGN ENVELOPE PERMANENT MAGNET MOTORS - DEPM

RATED POWER		DISCONNECT SWITCH RATING	FUSE RATING	FUSE CLASS TYPES	MAXIMUM DRIVER INPUT CURRENT (A)	
HP	KW				200 VAC	240 VAC
1	0.75	30A	10A	CC FAST-ACTING	3.1	2.7
1.5	1.1		10A		4.2	3.7
2	1.5		15A	J FAST-ACTING	6.0	4.8
3	2.2		20A		RK1 FAST-ACTING	8.8
5	4		30A	15.7		14.0
7.5	5.5	60A	50A	J FAST-ACTING	20.7	18.5
10	7.5		60A	RK1 FAST-ACTING	28.1	25.1

#### ARMSTRONG DISCONNECT SWITCH AND FUSE RATING - 3PH 200 -240V INPUT POWER FOR USE WITH DESIGN ENVELOPE PERMANENT MAGNET MOTORS - FRAME 71

RATED POWER		DISCONNECT SWITCH RATING	FUSE RATING	FUSE CLASS TYPES	MAXIMUM DRIVER INPUT CURRENT (A)	
HP	KW				200 VAC	240 VAC
0.33	0.25	30A	5	CC FAST-ACTING	1.5	1.2
0.5	0.37		6		2.1	1.8
0.75	0.55		10		2.9	2.6
1	0.75		10		3.5	3.1
1.5	1.1		15		4.8	4.6
2	1.5		20		6.4	5.9

#### ARMSTRONG DISCONNECT SWITCH AND FUSE RATING - 3PH 200-240V INPUT POWER FOR USE WITH DESIGN ENVELOPE PERMANENT MAGNET MOTORS - DEPM2

RATED POWER		DISCONNECT SWITCH RATING	FUSE RATING	FUSE CLASS TYPES	MAXIMUM DRIVER INPUT CURRENT (A)	
HP	KW				200 VAC	240 VAC
3	2.2	30A	20A	CC FAST-ACTING	7.4	6.4
5.5	4		30A		14.2	12.6
7.5	5.5		30A		19.0	16.6
10	7.5		30A		26.2	23.0

#### ARMSTRONG DISCONNECT SWITCH AND FUSE RATING - 3PH 380V-480V INPUT POWER FOR USE WITH DESIGN ENVELOPE PERMANENT MAGNET MOTORS - FRAME 71

RATED POWER		DISCONNECT SWITCH RATING	FUSE RATING	FUSE CLASS TYPES	MAXIMUM DRIVER INPUT CURRENT (A)	
HP	KW				380 VAC	480 VAC
0.33	0.25	30A	5A	CC FAST-ACTING	1.3	0.8
0.5	0.37		5A		1.6	1.1
0.75	0.55		6A	1.9	1.5	
1	0.75		6A	2.5	2.0	
1.5	1.1		10A	J FAST-ACTING	4.1	3.5
2	1.5		10A		5.3	3.9
3	2.2		10A	RK1 FAST-ACTING	6.5	5.8
4	3		15A		6.1	4.9
5	4		20A	9.2	7.1	
7.5	5.5		25A	12.5	8.2	
10	7.5	30A	18.5	14.5		

#### ARMSTRONG DISCONNECT SWITCH AND FUSE RATING - 3PH 380V-480V INPUT POWER FOR USE WITH DESIGN ENVELOPE PERMANENT MAGNET MOTORS - DEPM

RATED POWER		DISCONNECT SWITCH RATING	FUSE RATING	FUSE CLASS TYPES	MAXIMUM DRIVER INPUT CURRENT (A)	
HP	KW				380 VAC	480 VAC
1	0.75	30A	6A	CC FAST-ACTING	2.1	1.7
1.5	1.1		6A		2.8	2.3
2	1.5		10A	4.8	4.1	
3	2.2		10A	6.5	5.8	
4	3		15A	6.1	4.9	
5	4		20A	RK1 FAST-ACTING	9.2	7.1
7.5	5.5		25A		12.5	8.2
10	7.5		30A	18.5	14.5	

#### ARMSTRONG DISCONNECT SWITCH AND FUSE RATING - 3PH 380V-480V INPUT POWER FOR USE WITH DESIGN ENVELOPE PERMANENT MAGNET MOTORS - DEPM2

RATED POWER		DISCONNECT SWITCH RATING	FUSE RATING	FUSE CLASS TYPES	MAXIMUM DRIVER INPUT CURRENT (A)	
HP	KW				380 VAC	480 VAC
3	2.2	30A	10A	CC FAST-ACTING	3.9	3.2
4	3		10A		5.4	4.2
5.5	4		15A		7.1	5.7
7.5	5.5		15A		9.5	7.6
10	7.5		25A		13.6	11.3
15	11		30A		18.8	15.5



**ARMSTRONG DISCONNECT SWITCH AND FUSE RATING - 3PH 575-600V INPUT POWER FOR USE WITH DESIGN ENVELOPE PERMANENT MAGNET MOTORS - DEPM MOTORS**

RATED POWER		DISCONNECT SWITCH RATING	FUSE RATING	FUSE CLASS TYPES	MAXIMUM DRIVER INPUT CURRENT (A)	
HP	KW				575 VAC	600 VAC
1	0.75	30A	5A	CC FAST-ACTING J FAST-ACTING RK1 FAST-ACTING	1.6	1.3
1.5	1.1		6A		2.2	1.8
2	1.5		8A		2.0	1.6
3	2.2		10A		3.4	2.8
5	4		20A		5.5	4.9
7.5	5.5		25A		7.2	6.0
10	7.5		30A		9.8	9.4

**ARMSTRONG DISCONNECT SWITCH AND FUSE RATING - 3PH 575-600V INPUT POWER FOR USE WITH DESIGN ENVELOPE PERMANENT MAGNET MOTORS - DEPM2 MOTORS**

RATED POWER		DISCONNECT SWITCH RATING	FUSE RATING	FUSE CLASS TYPES	MAXIMUM DRIVER INPUT CURRENT (A)	
HP	KW				575 VAC	600 VAC
1	0.75	30A	5A	CC FAST-ACTING	1.6	1.5
1.5	1.1		6A		2.1	2.0
2	1.5		6A		2.6	2.6
3	2.2		6A		3.5	3.2
5	4		15A		5.7	5.3
7.5	5.5		15A		7.5	7.4
10	7.5		30A		10.8	10.1

All cabling and must comply with national and local regulations on cable cross-sections and ambient temperature

**9.0 PUMP MANAGER**

Pump Manager is a cloud based analytics service providing real time alerts and insights on the flow and the system's efficiency. Pump Manager provides unique and critical insights to drive savings in energy, maintenance, emergency repairs and downtime costs.

**Features**

**Secure IoT Connectivity**

Plug 'n play setup, no LAN connection required. Pump connected to the IBM Watson analytics platform cloud via a 4G LTE router with built-in cellular modem. Authentication key and 1-way push notifications only with no inbound communication to pumps make for safe connection

**Real Time Alerts**

Know of problems before they occur. Pump Manager will alert you when something is wrong

**Performance Reports**

You can now view operation trends and make data informed decisions

**Predictive Maintenance**

The pump will advise which parts it needs! And tell you where to buy them as well

**Building Management System Integration**

Integrate the pump data to your building automation system via API so you can view all your assets in one place

**Benefits**

**Lower Operating Costs**

- Optimal operation for maximum energy efficiency
- Lower OpEx costs

**Increase Availability & Reliability**

- Reduce unexpected failures
- Early problem detection
- Faster return to service

**Improve Comfort and Productivity**

- Keep flows in the desired range, reducing temperature swings

**Improve Building Resilience and Future Decisions**

- Make informed capital investment decisions

**Start Now in Two Easy Steps**

<http://armstrongfluidtechnology.com/en/registration> OR [info@armstrongfluidtechnology.com](mailto:info@armstrongfluidtechnology.com)

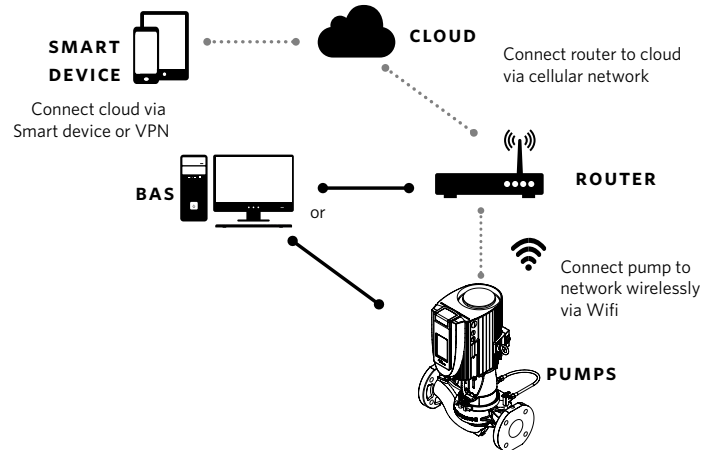

**10.0 CONNECTIVITY KIT**

**Pump Manger integration procedure**

This procedure describes the steps to connect an Armstrong Pump Manger router to a Design Envelope Pump with a DEPC controller.

Each site will be required to have a factory programmed router for data transfer (included with each Design Envelope Pump order).

Refer to **File No:** 100.8154 on Armstrong Corporate Website for full details.

**TORONTO**

23 BERTRAND AVENUE,  
TORONTO, ONTARIO,  
CANADA, M1L 2P3  
+1 416 755 2291

**BUFFALO**

93 EAST AVENUE, NORTH  
TONAWANDA, NEW YORK,  
U.S.A., 14120-6594  
+1 716 693 8813

**DROITWICH SPA**

POINTON WAY, STONEBRIDGE CROSS  
BUSINESS PARK, DROITWICH SPA,  
WORCESTERSHIRE,  
UNITED KINGDOM, WR9 0LW  
+44 121 550 5333

**MANCHESTER**

WOLVERTON STREET, MANCHESTER  
UNITED KINGDOM, M11 2ET  
+44 161 223 2223

**BANGALORE**

#18, LEWIS WORKSPACE, 3<sup>RD</sup> FLOOR,  
OFF MILLERS - NANDIDURGA ROAD,  
JAYAMAHAL CBD, BENSON TOWN,  
BANGALORE, INDIA 560 046  
+91 80 4906 3555

**SHANGHAI**

UNIT 903, 888 NORTH SICHUAN RD.  
HONGKOU DISTRICT, SHANGHAI  
CHINA, 200085  
+86 21 5237 0909

**BEIJING**

ROOM 1612, NANYIN BUILDING NO.2  
NORTH EAST THRID RING ROAD  
CHAOYANG DISTRICT, BEIJING,  
CHINA 100027  
+86 21 5237 0909

**SÃO PAULO**

RUA JOSÉ SEMIÃO RODRIGUES  
AGOSTINHO, 1370 GALPÃO 6 EMBU  
DAS ARTES, SAO PAULO, BRAZIL  
+55 11 4785 1330

**LYON**

93 RUE DE LA VILLETTE  
LYON, 69003 FRANCE  
+33 4 26 83 78 74

**DUBAI**

JAFZA VIEW 19, OFFICE 402  
P.O. BOX 18226 JAFZA,  
DUBAI - UNITED ARAB EMIRATES  
+971 4 887 6775

**JIMBOLIA**

STR CALEA MOTILOR NR. 2C  
JIMBOLIA 305400, JUD.TIMIS  
ROMANIA  
+40 256 360 030

**FRANKFURT**

WESTERBACHSTRASSE 32,  
D-61476 KRONBERG IM TAUNUS  
GERMANY  
+49 6173 999 77 55

**ARMSTRONG FLUID TECHNOLOGY®**  
ESTABLISHED 1934

**ARMSTRONGFLUIDTECHNOLOGY.COM**