

# Condensate pump for oil condensing boilers with neutralisation tank

Lift NT25 series, K1 product group



## TECHNICAL DATA

Electrical connection:	230 V, 50/60 Hz
Input power:	40 W
Alarm contact:	max. 230 V, 8 A (resistive load), NO normally open/NC normally closed
Protection class:	IP 20
Medium:	condensate pH $\geq 3$ , temperature 70 °C max
Rate of flow:	max. 14 l/h
Pressure head:	max. 10 m
Noise level:	max. 36 dB [A]
Dimensions:	244 x 174 x 261 mm (L x W x H)
Condensate supply:	$\varnothing$ 40 mm
Condensate suction head:	200 mm
Neutralisation tank:	ABS plastic, 6.0 l/1.59 Gal, incl. neutralisation granulate (1 kg)
Condensation drain:	nozzles for hose connection $\varnothing$ 8 x 2 mm
Weight:	2.7 kg

## PRODUCT FEATURES

- fully automatic condensate pump delivered completely ready for connection, incl. neutralisation tank
- noise-reducing electronic controls with follow-up time to reduce switching frequency
- space-saving construction
- integrated collection/neutralisation tank, incl. first fill with neutralisation granulate (1 kg) - sufficient for about 12 months for systems up to 25 kW
- upstream suction filter as well as check valve for discharge hose
- connection for discharge hose ( $\varnothing$  6 x 1.5 mm)
- pre-mounted power cable (1.0 m) incl. shockproof plug
- overflow protection through separate float
- potential-free alarm connection (NO normally open/NC normally closed)

## USE

The Lift NT25 condensate pump is a fully automatic unit for the extraction of condensate, produced in gas/oil condensing boilers, air-conditioning systems, refrigerated counters and dehumidifiers incl. collection/neutralisation tank. It can be used anywhere where a condensate disposal through gravity is not possible or where there is no direct drain. The Lift NT25 condensate pump is designed for gas and oil condensing boilers up to 25 kW. It is extensible for systems up to 100 kW with additional accessories NB2 and NT50.

The housing is made from ABS plastic and is therefore resistant to acidic condensate (pH  $\geq 3$ ).

For the use in oil condensing boilers we recommend the additional use of an extensionkit with activated carbon (see accessories for condensate pumps).

## SCHEMATIC SKETCH LIFT NT25

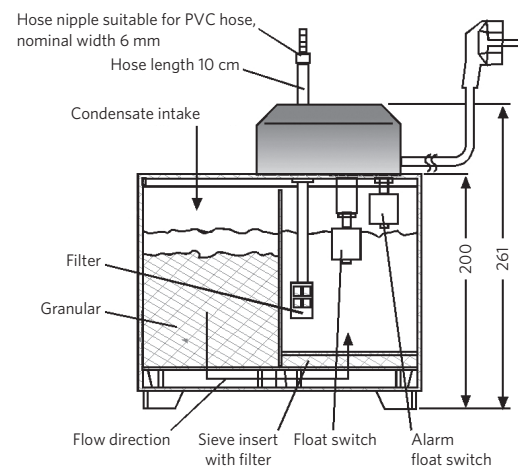

## MAIN AREAS OF USE

- gas condensing boilers
- oil condensing boilers

## FLOW MEDIA

- condensates produced in gas and oil condensing boilers with a 70 °C max temperature.
- condensates with oil residues from oil condensing boilers must be cleaned with activated carbon (extension kit) if necessary.

## TEMPERATURE RANGE

Ambient temperature:	+5 °C to +45 °C
Media temperature:	+2 °C to +70 °C

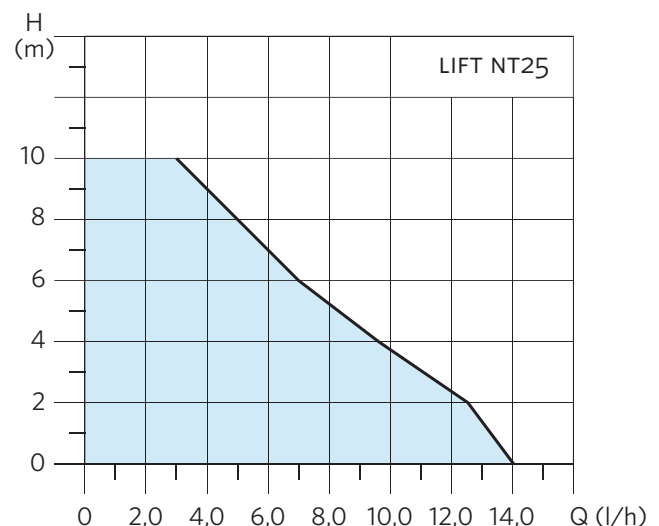

# Condensate pump for oil condensing boilers with neutralisation tank

Lift NT25 series, K1 product group

## DELIVERY PROGRAM

TYPE	MAX PRESSURE HEAD	MAX RATE OF FLOW	FOR CONDENSING BOILERS UP TO	REMARKS	PRODUCT NO.
LIFT NT25	10 M	14 L/H	25 KW	INCL. NEUTRALISATION TANK INCL. FIRST FILL WITH NEUTRALISATION GRANULATE	0341-00025-072

## CONNECTION ALARM CABLE

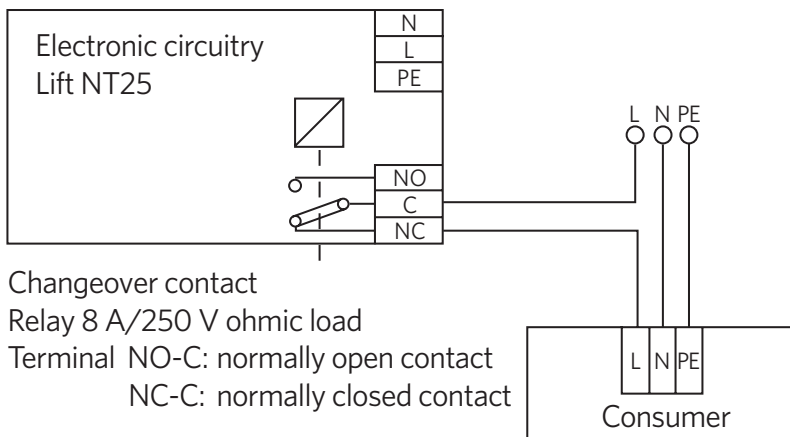

## CONNECTION EXAMPLE FOR POTENTIAL-FREE CONTACT

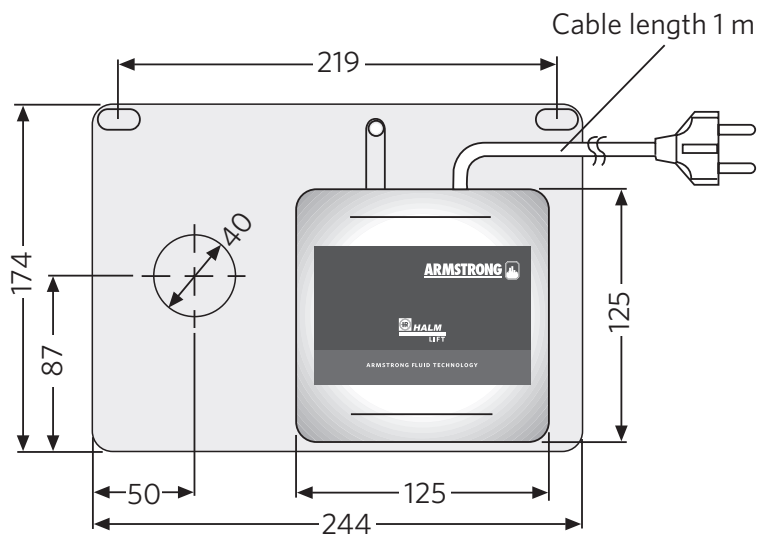



IN CASE OF QUESTIONS OR FOR ORDERS,  
PLEASE CONTACT US AT

[GERMANY@ARMSTRONGFLUIDTECHNOLOGY.COM](mailto:GERMANY@ARMSTRONGFLUIDTECHNOLOGY.COM)

FOR MORE INFORMATION, PLEASE GO TO

[WWW.HALM-PUMPS.DE](http://WWW.HALM-PUMPS.DE)

**TORONTO, CANADA**

+1 416 755 2291

**BUFFALO, USA**

+1 716 693 8813

**SÃO PAULO, BRAZIL**

+55 (11) 4781 5500

**BIRMINGHAM, UK**

+44 (0) 8444 145 145

**MANCHESTER, UK**

+44 (0) 8444 145 145

**LYON, FRANCE**

+33 (0) 420 102 625

**MANNHEIM, GERMANY**

+49 (0) 621 3999 9858

**DUBAI, UAE**

+971 4 8876775

**BANGALORE, INDIA**

+91 (0) 80 4906 3555

**SHANGHAI, CHINA**

+86 (0) 21 3756 6696

**ARMSTRONG FLUID TECHNOLOGY**  
ESTABLISHED 1934

[ARMSTRONGFLUIDTECHNOLOGY.COM](http://ARMSTRONGFLUIDTECHNOLOGY.COM)

**MAKING  
ENERGY  
MAKE  
SENSE™**

FILE NO.: 11.276DE-EN  
DATE: NOV. 23, 2018

SUPERSEDES: NEW  
DATE: NEW