

Circulation pumps for drinking water with stainless steel housing, pressure head 7-12 m

BGPA (N) series, T3 product group



TECHNICAL DATA

Rate of flow: up to 12.0 m³/h
 Pressure head: up to 12 m
 Media temperature: +2 °C to +110 °C
 Installation length: 180 mm
 Threaded connection: 1¼" and 1½"
 Protection class: IP 44
 Insulation class: H
 Nominal pressure: PN 10
 Control: 3-step switch with manual speed selection

PRODUCT FEATURES

- manual start-up feature
- space-saving axially integrated terminal box
- pump housing in stainless steel

USE

The BGPA (N) series circulation pumps are wet rotor circulators designed for use in drinking water systems with a flow rate of > 5 m³/h. They feature a corrosion-resistant housing in stainless steel and are thus designed for use in drinking water circulation systems.

MATERIALS

Component	Material	Material no.
Pump housing	Stainless steel	1.4308
Impeller	Polypropylene (PP - GF 30)	
Shaft	Ceramic	
Bearing	Ceramic	
Bearing plate	Brass	2.0401
Can	Stainless steel	1.4301

TEMPERATURE RANGE

Ambient temperature: 0 °C to +40 °C
 Temperature class: TF 110
 Media temperature: +2 °C to +110 °C

AMBIENT TEMPERATURE

To avoid the build-up of condensation, the ambient temperature must always be lower than the media temperature.

Ambient temp.	Media temp. min.	Media temp. max.
0	2	110
10	10	110
20	20	110
30	30	110
35	35	110
40	40	110

MOTOR PROTECTION

External motor protection is not required.

SPEED SWITCHING

The respective speed is set via a rotary switch integrated in the axial terminal box.

MINIMUM INFLOW PRESSURE

Please determine the minimum inflow pressure for corresponding temperature from the following table.

Media temperature	< 85 °C	90 °C	110 °C
Minimum inflow pressure	0.05 bar	0.3 bar	1.10 bar

SOUND PRESSURE LEVEL

The sound pressure level is < 45 dB (A).

FLOW MEDIA

Only for drinking water up to a temperature of 65 °C and a max. degree of hardness of 14 °dH (temporary hardness).

Circulation pumps for drinking water with stainless steel housing, pressure head 7-12 m

BGPA (N) series, T3 product group

TECHNICAL DATA

TYPE	CONNECTION PIPE	THREADED CONNECTION	INSTALLATION LENGTH (MM)	VOLTAGE / FREQUENCY	P1 (W)	I _{MAX} (A)	NET-WEIGHT (KG)	PRODUCT NO.
BGPA 20-7.0 N180	¾"	1¼"	180	230 V/50 HZ	220 ... 260	1,13	6,3	0352-40207-71
BGPA 20-8.0 N180	¾"	1¼"	180	230 V/50 HZ	260 ... 286	1,25	6,3	0352-40208-71
BGPA 20-10.0 N180	¾"	1¼"	180	230 V/50 HZ	283 ... 357	1,56	6,3	0352-40210-71
BGPA 20-12.0 N180	¾"	1¼"	180	230 V/50 HZ	285 ... 400	1,73	6,3	0352-40212-71
BGPA 25-7.0 N180	1"	1½"	180	230 V/50 HZ	220 ... 260	1,13	6,4	0353-40207-71
BGPA 25-8.0 N180	1"	1½"	180	230 V/50 HZ	260 ... 286	1,25	6,4	0353-40208-71
BGPA 25-10.0 N180	1"	1½"	180	230 V/50 HZ	283 ... 357	1,56	6,4	0353-40210-71
BGPA 25-12.0 N180	1"	1½"	180	230 V/50 HZ	285 ... 400	1,73	6,4	0353-40212-71

PERFORMANCE CURVES

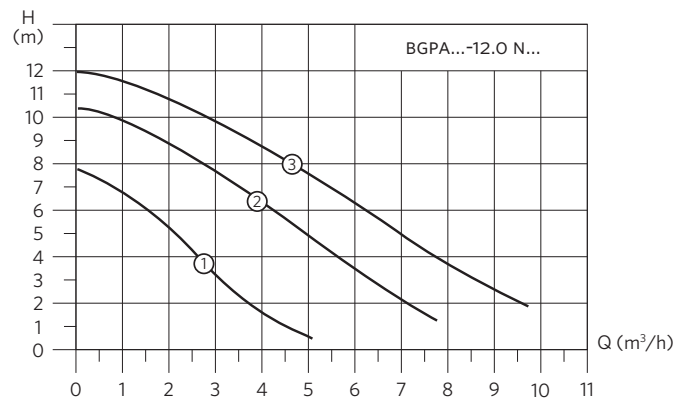
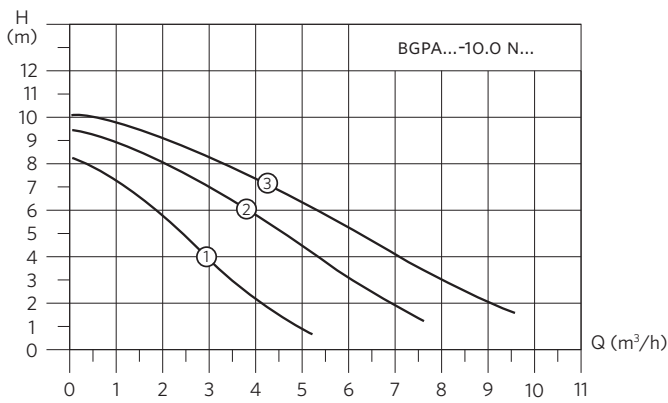
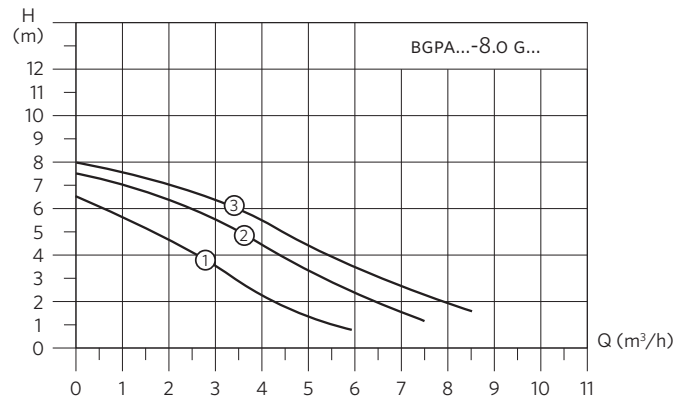
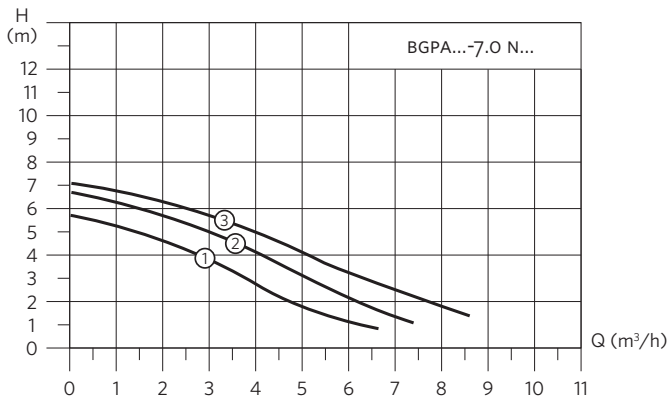

DIMENSIONS

TYPE	L1 (MM)	L2 (MM)	L3 (MM)	L4 (MM)
BGPA (N)	180	135.5	166	206

DIMENSION ILLUSTRATION

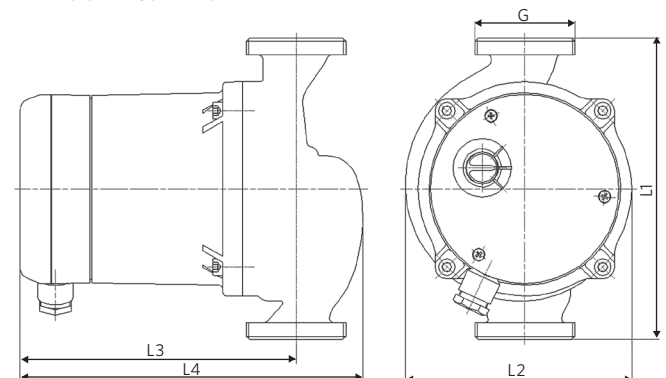



FOR MORE INFORMATION, CONTACT YOUR
ARMSTRONG REPRESENTATIVE OR VISIT US AT:
ARMSTRONGFLUIDTECHNOLOGY.COM/CONTACTUS

TORONTO, CANADA

+1 416 755 2291

BUFFALO, USA

+1 716 693 8813

SÃO PAULO, BRAZIL

+55 (11) 4781 5500

BIRMINGHAM, UK

+44 (0) 8444 145 145

MANCHESTER, UK

+44 (0) 8444 145 145

LYON, FRANCE

+33 (0) 420 102 625

MANNHEIM, GERMANY

+49 (0) 621 3999 9858

DUBAI, UAE

+971 4 8876775

BANGALORE, INDIA

+91 (0) 80 4906 3555

SHANGHAI, CHINA

+86 (0) 21 3756 6696

ARMSTRONG FLUID TECHNOLOGY
ESTABLISHED 1934

ARMSTRONGFLUIDTECHNOLOGY.COM

**MAKING
ENERGY
MAKE
SENSE™**

FILE NO.: 11.262EU
DATE: DEC. 09, 2018

SUPERSEDES: NEW
DATE: NEW