

VERTICAL TURBINE ELECTRIC FIRE PUMP | 14×19MH VTF WITH 14×24.5 FABRICATED STEEL HEAD | SUBMITTAL

File No: F51.548
Date: APRIL 28, 2025
Supersedes: F51.548
Date: AUGUST 15, 2005

Job: _____ Representative: _____
 _____ Order no.: _____ Date: _____
 Engineer: _____ Submitted by: _____ Date: _____
 Contractor: _____ Approved by: _____ Date: _____

Model: 14 × 19MH VTF **Discharge head:** 14 × 24.5 F
rpm: 1770 Water lube **4500 gpm:** _____ T.D.H
 FM UL NFPA-20 only Approval Construction
Motor: _____ **HP:** _____
Volt: _____ **pH:** _____
Hz: _____
 Controller model: _____

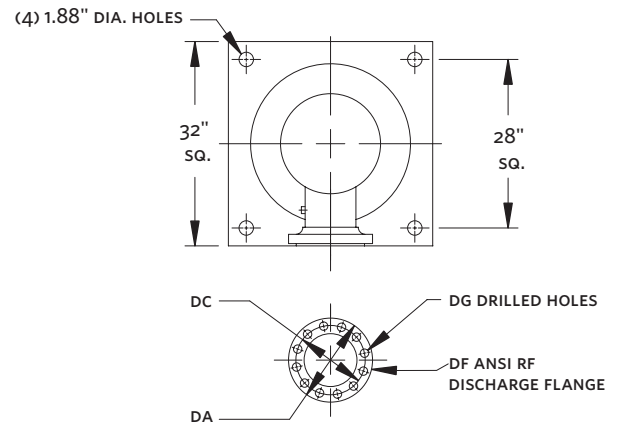
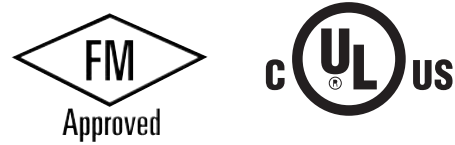

PRESS RATE	DISCHARGE FLANGE inch (mm)					
	DA	DC	DD	DF	DG	DK
150#	21.00 (533)	18.75 (476)	17.00 (432)	14.00 (356)	1.13 (29)	1.38 (35)

NO OF STG'S	DISCHARGE SIZE inch (mm)	RATING	DIMENSION inch (mm)		
			AG*	B	C
2	14.00 (356)	150	65.25 (1657)	51.75 (1315)	1.94 (43)
2	14.00 (356)	150	65.25 (1657)	51.75 (1315)	2.25 (57)

NOTES

- Dimensions are in inches unless otherwise indicated.
- When motor is oil lubricated, oil is not furnished. See operation manual for manufacturer's recommendations.
- Not to be used for construction unless certified.
- * Dimension based on motor height of a standard WP-I Hollow shaft motor. Subject to change depending on motor mfg. and/or the use of a motor adaptor.

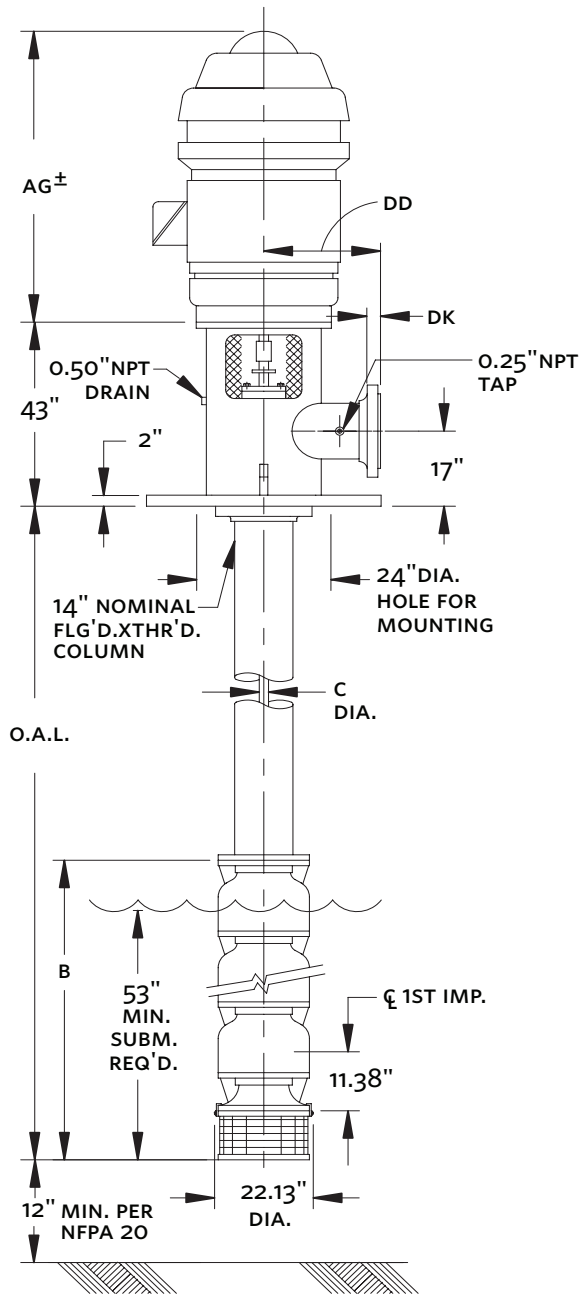

TORONTO
+1 416 755 2291

BUFFALO
+1 716 693 8813

DROITWICH SPA
+44 8444 145 145

MANCHESTER
+44 8444 145 145

BANGALORE
+91 80 6510 3555

SHANGHAI
+86 21 5237 0909

BEIJING
+86 21 5237 0909

SÃO PAULO
+55 11 4785 1330

LYON
+33 4 20 10 26 21

DUBAI
+971 4 887 6775

JIMBOLIA
+40 256 360 030

FRANKFURT
+49 6173 999 77 55