

VERTICAL TURBINE ELECTRIC FIRE PUMP | 12x18H VTF WITH 12x20 CAST IRON HEAD | SUBMITTAL

File No: F51.540
Date: APRIL 28, 2025
Supersedes: F51.540
Date: AUGUST 15, 2005

Job: _____ Representative: _____
 _____ Order no.: _____ Date: _____
 Engineer: _____ Submitted by: _____ Date: _____
 Contractor: _____ Approved by: _____ Date: _____

Model: 12 x 18H VTF **Discharge head:** 12 x 20 A
rpm: 1770 Water lube **4000 gpm:** _____ T.D.H
 FM UL NFPA-20 only Approval Construction
Motor: _____ **HP:** _____
Volt: _____ **pH:** _____
Hz: _____
 Controller model: _____

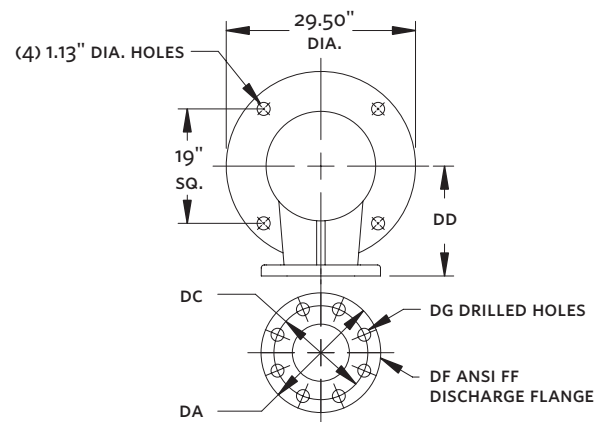
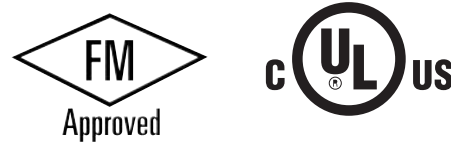

PRESS RATE	DISCHARGE FLANGE inch (mm)					
	DA	DC	DD	DF	DG	DK
125 #	19.00 (483)	17.00 (432)	16.50 (419)	12.00 (304)	1.00 (25)	1.25 (32)

NO OF STG'S	DISCHARGE SIZE	RATING	DIMENSION inch (mm)		
	inch (mm)		AG*	B	C
2	12.00 (305)	125	61.88 (1572)	54.00 (1372)	1.94 (49)

NOTES

- Dimensions are in inches unless otherwise indicated.
- When motor is oil lubricated, oil is not furnished. See operation manual for manufacturer's recommendations.
- Not to be used for construction unless certified.
- * Dimension based on motor height of a standard WP-I Hollow shaft motor. Subject to change depending on motor mfg. and/or the use of a motor adaptor.

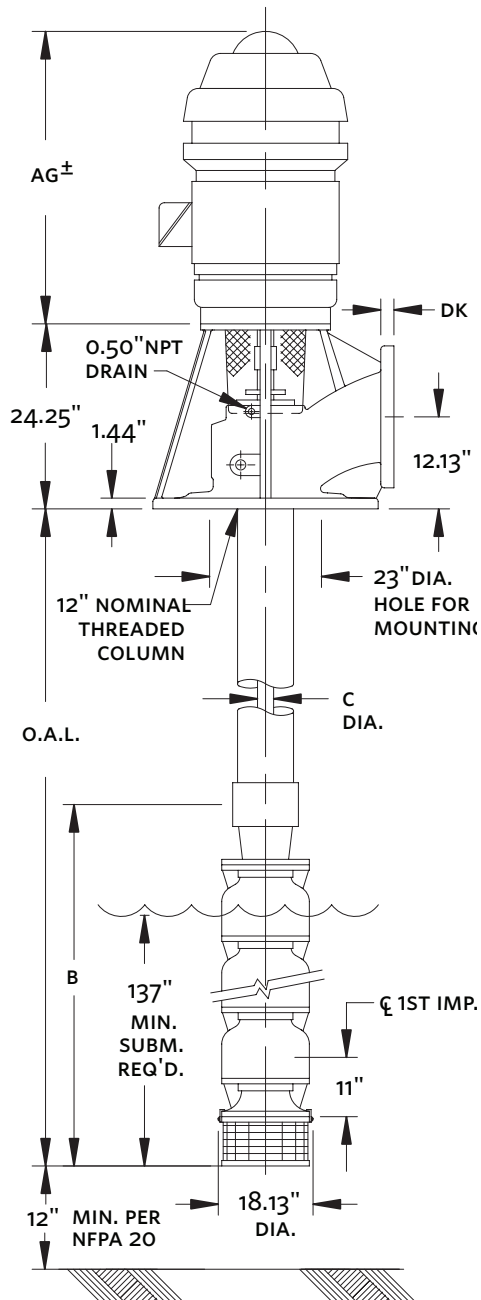

TORONTO
+1 416 755 2291

BUFFALO
+1 716 693 8813

DROITWICH SPA
+44 8444 145 145

MANCHESTER
+44 8444 145 145

BANGALORE
+91 80 6510 3555

SHANGHAI
+86 21 5237 0909

BEIJING
+86 21 5237 0909

SÃO PAULO
+55 11 4785 1330

LYON
+33 4 20 10 26 21

DUBAI
+971 4 887 6775

JIMBOLIA
+40 256 360 030

FRANKFURT
+49 6173 999 77 55