

VERTICAL TURBINE ELECTRIC FIRE PUMP | 8x12M VTF WITH 8x20 FABRICATED STEEL HEAD | SUBMITTAL

File No: F51.510
Date: APRIL 28, 2025
Supersedes: F51.510
Date: AUGUST 15, 2005

Job: _____ Representative: _____
 _____ Order no.: _____ Date: _____
 Engineer: _____ Submitted by: _____ Date: _____
 Contractor: _____ Approved by: _____ Date: _____

Model: 8 x 12M VTF **Discharge head:** 8 x 20 F
rpm: 1770 Water lube **750 gpm:** _____ T.D.H
 FM UL NFPA-20 only Approval Construction
Motor: _____ **HP:** _____
Volt: _____ **pH:** _____
Hz: _____
 Controller model: _____

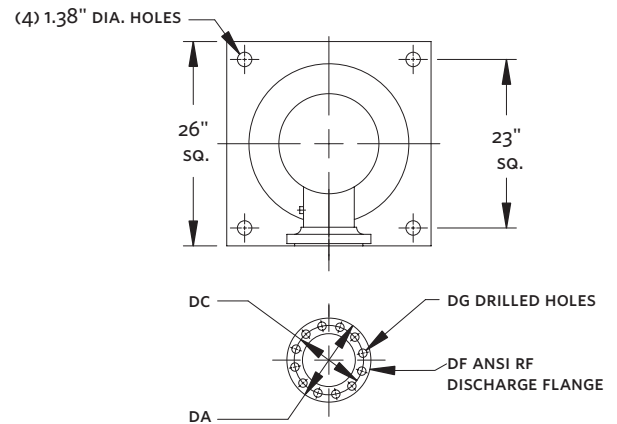
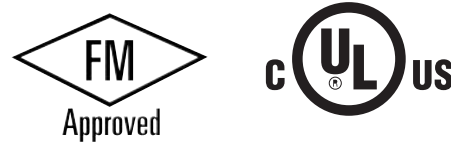

PRESS RATE	DISCHARGE FLANGE inch (mm)					
	DA	DC	DD	DF	DG	DK
300 #	15.00 (381)	13.00 (330)	13.00 (330)	8.00 (203)	1.00 (25)	1.63 (41)

NO OF STG'S	DISCHARGE SIZE inch (mm)	RATING	DIMENSION inch (mm)		
			AG*	B††	C
11	8.00 (203)	300	53.44 (1357)	117.88 (2994)	1.69 (43)
12	8.00 (203)	300	53.44 (1357)	127.25 (3232)	1.69 (43)
13	8.00 (203)	300	53.44 (1357)	136.63 (3470)	1.69 (43)
14	8.00 (203)	300	61.88 (1572)	146.00 (3683)	1.94 (49)
15	8.00 (203)	300	61.88 (1572)	155.38 (3947)	1.94 (49)
16	8.00 (203)	300	61.88 (1572)	164.75 (4185)	1.94 (49)

NOTES

- Dimensions are in inches unless otherwise indicated.
- When motor is oil lubricated, oil is not furnished. See operation manual for manufacturer's recommendations.
- Not to be used for construction unless certified.
- * Dimension based on motor height of a standard WP-I Hollow shaft motor. Subject to change depending on motor mfg. and/or the use of a motor adaptor.
- ‡ No discharge case supplied eleven stages and above.
- † Ductile iron bowls required eleven stages and above.

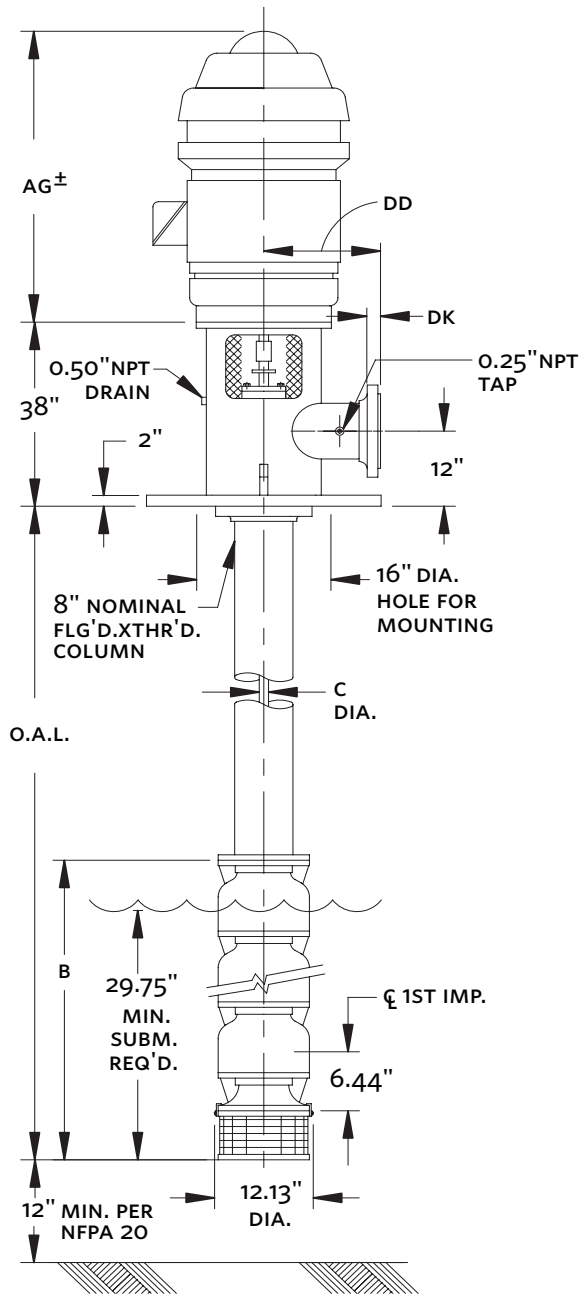

TORONTO
+1 416 755 2291

BUFFALO
+1 716 693 8813

DROITWICH SPA
+44 8444 145 145

MANCHESTER
+44 8444 145 145

BANGALORE
+91 80 6510 3555

SHANGHAI
+86 21 5237 0909

BEIJING
+86 21 5237 0909

SÃO PAULO
+55 11 4785 1330

LYON
+33 4 20 10 26 21

DUBAI
+971 4 887 6775

JIMBOLIA
+40 256 360 030

FRANKFURT
+49 6173 999 77 55