

VERTICAL TURBINE DIESEL FIRE PUMP | 12x18H VTF WITH 12x20 CAST STEEL HEAD | SUBMITTAL

File No: F51.640
Date: APRIL 10, 2025
Supersedes: F51.640
Date: JULY 15, 2013

Job: _____ Representative: _____
 _____ Order no.: _____ Date: _____
 Engineer: _____ Submitted by: _____ Date: _____
 Contractor: _____ Approved by: _____ Date: _____

Model: 12x18H VTF **Discharge head:** 12x20 A

RPM: 1770 Water lube

4000 GPM: _____ T.D.H

- FM UL NFPA-20 only
- Approval Construction
- Engine model: _____
- Ragd model: _____
- Shaft model: _____
- Controller model: _____

NOTES

- Dimension based on randolph gear drive. May vary when driver adaptor is required.
- Dimensions are in inches unless otherwise indicated.
- Engine to base mounting and cooling loop to be field installed and plumbed.
- Engine oil & anti freeze/coolant may not be included.
- Gear shipped filled with oil. Check level before installation.
- Refer dwg. no. _____ for Engine dimensions.
- Not to be used for construction unless certified.

PRESS RATE	DISCHARGE FLANGE INCH (mm)					
	DA	DC	DD	DF	DG	DK
125 #	19.00 (483)	17.00 (432)	16.50 (419)	12.00 (304)	1.00 (25)	1.25 (32)



NO OF STG'S	DISCHARGE SIZE	RATING	RAGD	AG*	B	C	H*	I*	L	AA
	INCH (mm)		HP	INCH (mm)						
2	12.00 (305)	125	400	36.00 (914)	54.00 (1372)	1.94 (49)	13.75 (349)	21.75 (553)	—	—
2	12.00 (305)	125	500	45.44 (1154)	54.00 (1372)	1.94 (49)	18.75 (476)	28.00 (711)	—	—

* Dimension based on randolph gear drive. May vary when driver adaptor is required.

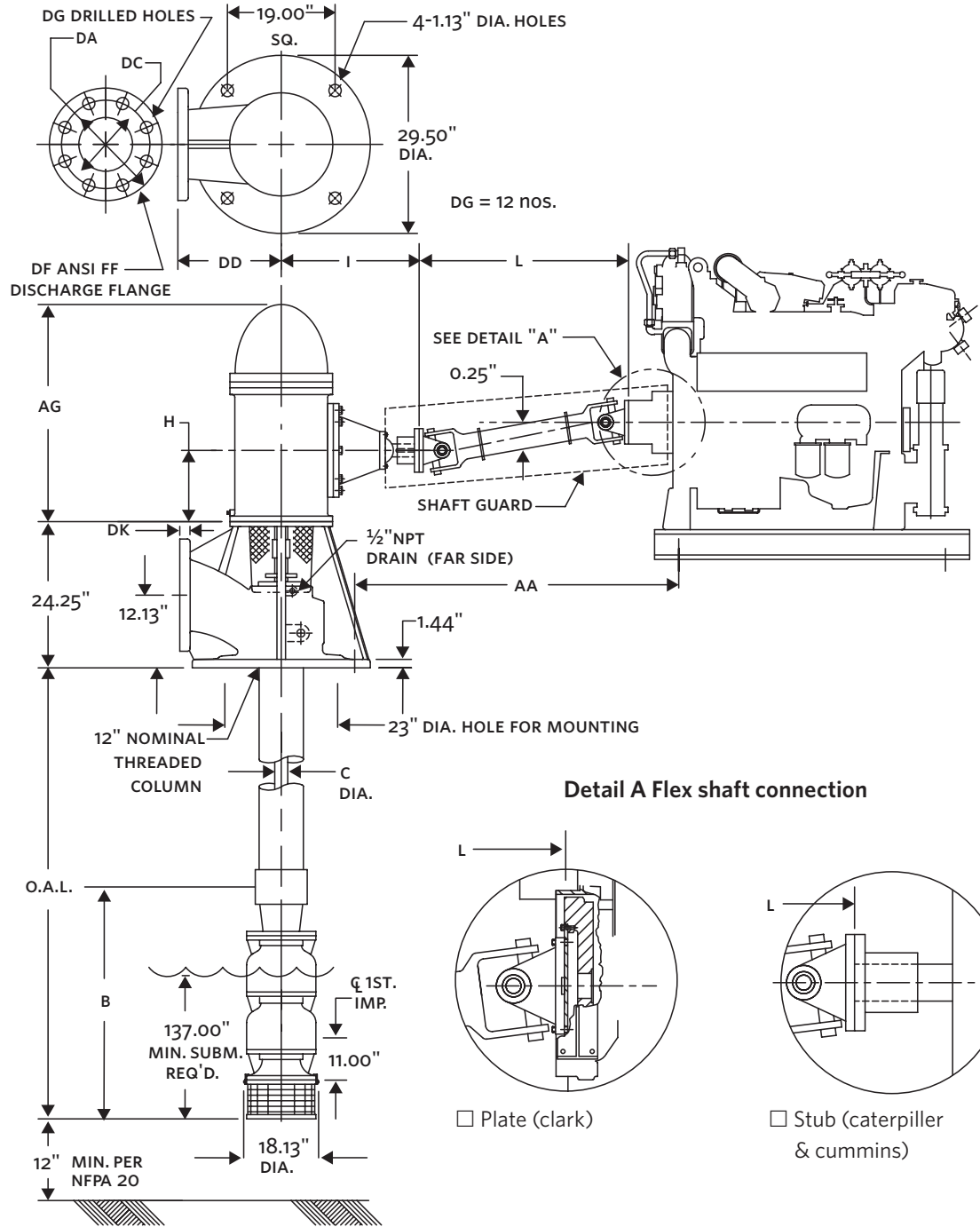

TORONTO
+1 416 755 2291

BUFFALO
+1 716 693 8813

DROITWICH SPA
+44 8444 145 145

MANCHESTER
+44 8444 145 145

BANGALORE
+91 80 4906 3555

SHANGHAI
+86 21 5237 0909

BEIJING
+86 21 5237 0909

SÃO PAULO
+55 11 4785 1330

LYON
+33 4 20 10 26 21

DUBAI
+971 4 887 6775

JIMBOLIA
+40 256 360 030

FRANKFURT
+49 6173 999 77 55