

VERTICAL TURBINE DIESEL FIRE PUMP | 10×16M VTF WITH 10×20 FABRICATED STEEL HEAD | SUBMITTAL

File No: F51.630
Date: APRIL 10, 2025
Supersedes: F51.630
Date: JULY 15, 2013

Job: _____ Representative: _____
 _____ Order no.: _____ Date: _____
 Engineer: _____ Submitted by: _____ Date: _____
 Contractor: _____ Approved by: _____ Date: _____

Model: 10×16M VTF **Discharge head:** 10×20 F

RPM: 1770 Water lube

2500 GPM: _____ T.D.H

- FM UL NFPA-20 only
- Approval Construction
- Engine model: _____
- Ragd model: _____
- Shaft model: _____
- Controller model: _____

NOTES

- Dimension based on randolph gear drive. May vary when driver adaptor is required.
- Dimensions are in inches unless otherwise indicated.
- Engine to base mounting and cooling loop to be field installed and plumbed.
- Engine oil & anti freeze/coolant may not be included.
- Gear shipped filled with oil. Check level before installation.
- Refer dwg. no. _____ for Engine dimensions.
- Not to be used for construction unless certified.

PRESS RATE	DISCHARGE FLANGE INCH (mm)					
	DA	DC	DD	DF	DG	DK
300 #	17.50 (445)	15.25 (387)	14.00 (356)	10.00 (254)	1.13 (29)	1.88 (49)



NO OF STG'S	DISCHARGE SIZE	RATING	RAGD	AG*	B	C	H*	I*	L	AA
	INCH (mm)		HP	INCH (mm)						
5	10.00 (254)	300	400	45.44 (1154)	96.13 (2441)	1.94 (49)	18.75 (476)	28.00 (711)	—	—

* Dimension based on randolph gear drive. May vary when driver adaptor is required.

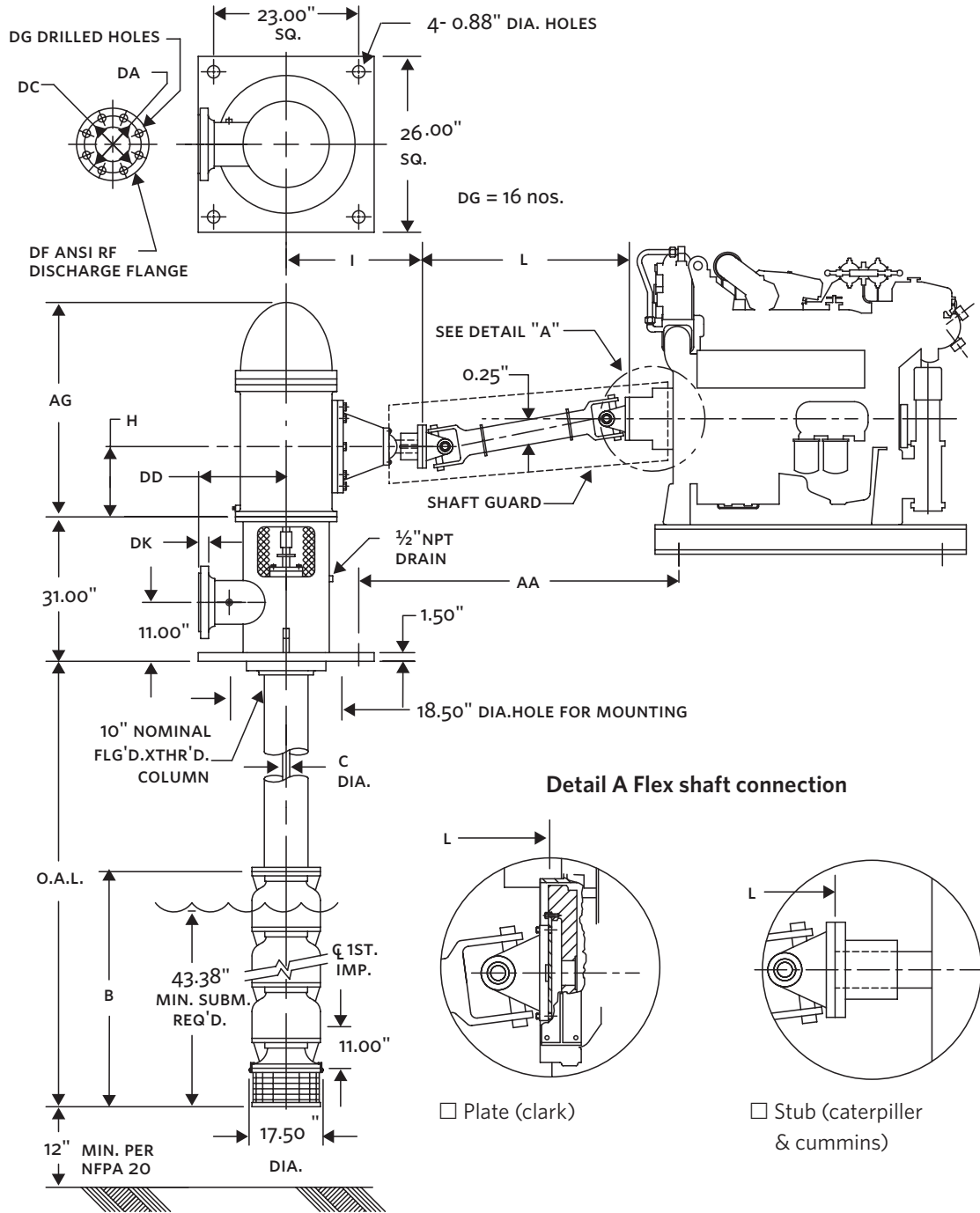

TORONTO
+1 416 755 2291

BUFFALO
+1 716 693 8813

DROITWICH SPA
+44 8444 145 145

MANCHESTER
+44 8444 145 145

BANGALORE
+91 80 4906 3555

SHANGHAI
+86 21 5237 0909

BEIJING
+86 21 5237 0909

SÃO PAULO
+55 11 4785 1330

LYON
+33 4 20 10 26 21

DUBAI
+971 4 887 6775

JIMBOLIA
+40 256 360 030

FRANKFURT
+49 6173 999 77 55