

VERTICAL TURBINE DIESEL FIRE PUMP | 8×12H VTF WITH 8×16½ CAST IRON HEAD | SUBMITTAL

File No: F51.620
Date: APRIL 10, 2025
Supersedes: F51.620
Date: JULY 15, 2013

Job: _____ Representative: _____

Order no.: _____ Date: _____

Engineer: _____ Submitted by: _____ Date: _____

Contractor: _____ Approved by: _____ Date: _____

Model: 8×12H VTF **Discharge head:** 8×16½ A

RPM: 1770 Water lube

1500 GPM: _____ T.D.H

- FM UL NFPA-20 only
- Approval Construction
- Engine model: _____
- Ragd model: _____
- Shaft model: _____
- Controller model: _____

NOTES

- Dimension based on randolph gear drive. May vary when driver adaptor is required.
- Dimensions are in inches unless otherwise indicated.
- Engine to base mounting and cooling loop to be field installed and plumbed.
- Engine oil & anti freeze/coolant may not be included.
- Gear shipped filled with oil. Check level before installation.
- Refer dwg. no. _____ for Engine dimensions.
- Not to be used for construction unless certified.

| PRESS RATE | DISCHARGE FLANGE INCH (mm) | | | | | |
|------------|----------------------------|----------------|----------------|---------------|--------------|--------------|
| | DA | DC | DD | DF | DG | DK |
| 125 # | 13.50 (343) | 11.75 (299) | 11.50 (292) | 8.00 (203) | 0.88 (22) | 1.13 (29) |
| 250# | 15.00 (381) | 13.00 (330) | 12.00 (305) | 8.00 (203) | 1.00 (25) | 1.63 (41) |



| NO OF STG'S | DISCHARGE SIZE | RATING | RAGD | AG* | B | C | H* | I* | L | AA |
|-------------|----------------|--------|---------|-------------|---------------|-----------|-------------|-------------|---|----|
| | INCH (mm) | | HP | INCH (mm) | | | | | | |
| 4 | 8.00 (203) | 125 | 125 | 27.00 (685) | 69.19 (1757) | 1.50 (38) | 11.44 (291) | 18.00 (457) | — | — |
| 5 | 8.00 (203) | 125 | 150-200 | 34.00 (864) | 79.50 (2019) | 1.50 (38) | 13.75 (349) | 20.94 (532) | — | — |
| 5 | 8.00 (203) | 250 | 200 | 34.00 (864) | 79.50 (2019) | 1.50 (38) | 13.75 (349) | 20.94 (532) | — | — |
| 6 | 8.00 (203) | 250 | 200 | 34.00 (864) | 89.81 (2281) | 1.50 (38) | 13.75 (349) | 20.94 (532) | — | — |
| 6 | 8.00 (203) | 250 | 250 | 34.00 (864) | 89.81 (2281) | 1.50 (38) | 13.75 (349) | 21.75 (553) | — | — |
| 6 | 8.00 (203) | 250 | 250 | 34.00 (864) | 89.81 (2281) | 1.69 (43) | 13.75 (349) | 21.75 (553) | — | — |
| 7 | 8.00 (203) | 250 | 250-300 | 34.00 (864) | 100.13 (2543) | 1.69 (43) | 13.75 (349) | 21.75 (553) | — | — |
| 8 | 8.00 (203) | 250 | 250-300 | 34.00 (864) | 110.44 (2805) | 1.69 (43) | 13.75 (349) | 21.75 (553) | — | — |
| 9 | 8.00 (203) | 250 | 300 | 34.00 (864) | 120.75 (3067) | 1.94 (49) | 15.31 (389) | 21.75 (553) | — | — |
| 9 | 8.00 (203) | 250 | 300 | 36.00 (914) | 120.75 (3067) | 1.94 (49) | 15.31 (389) | 21.75 (553) | — | — |
| 10 | 8.00 (203) | 250 | 300 | 36.00 (914) | 131.06 (3329) | 1.94 (49) | 15.31 (389) | 21.75 (553) | — | — |

* Dimension based on randolph gear drive. May vary when driver adaptor is required.

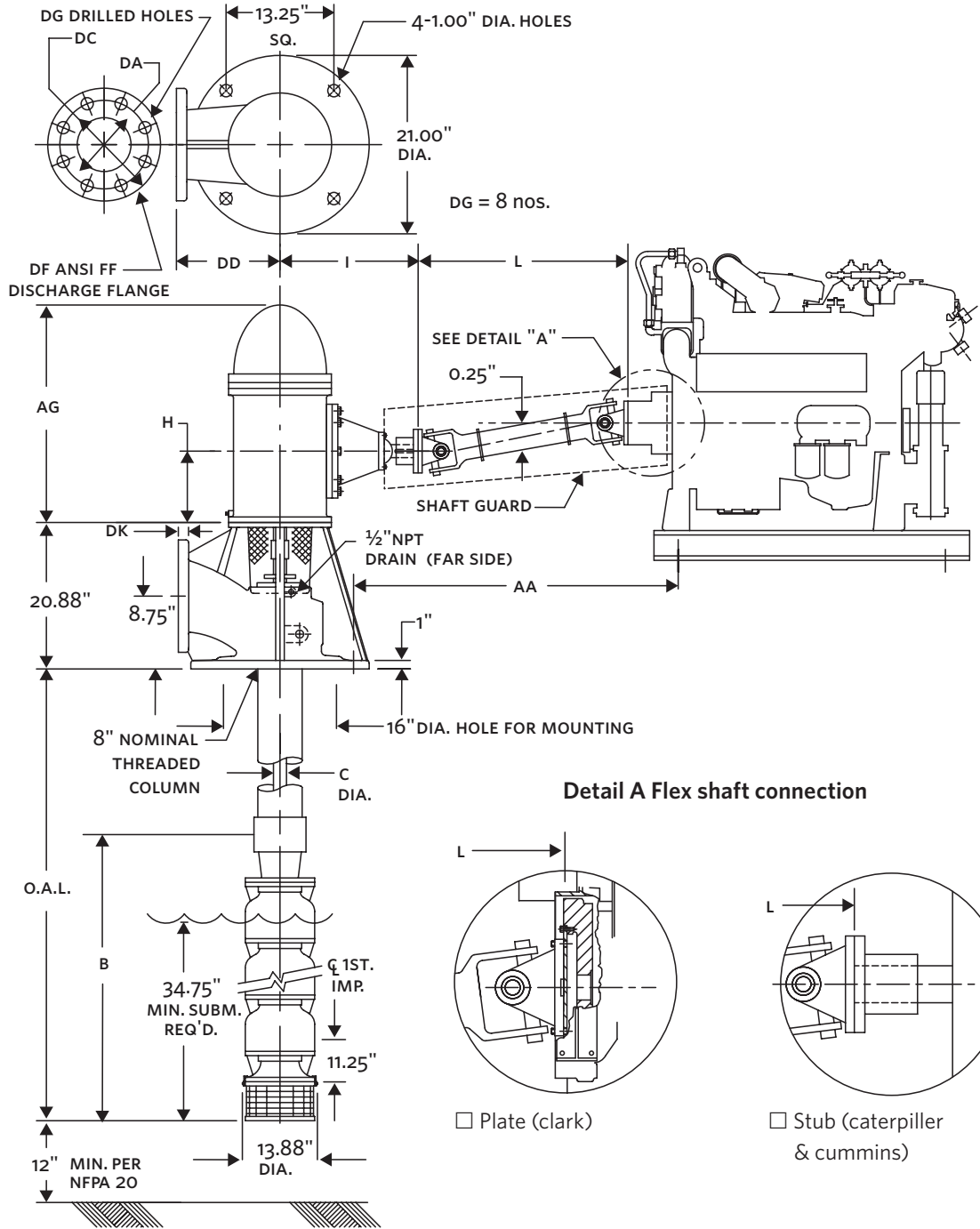

- TORONTO
+1 416 755 2291
- BUFFALO
+1 716 693 8813
- DROITWICH SPA
+44 8444 145 145
- MANCHESTER
+44 8444 145 145
- BANGALORE
+91 80 4906 3555
- SHANGHAI
+86 21 5237 0909
- BEIJING
+86 21 5237 0909
- SÃO PAULO
+55 11 4785 1330
- LYON
+33 4 20 10 26 21
- DUBAI
+971 4 887 6775
- JIMBOLIA
+40 256 360 030
- FRANKFURT
+49 6173 999 77 55