

## VERTICAL TURBINE DIESEL FIRE PUMP | 8x12M VTF WITH 8x20 FABRICATED STEEL HEAD | SUBMITTAL

File No: F51.610  
Date: APRIL 10, 2025  
Supersedes: F51.610  
Date: JULY 15, 2013

Job: \_\_\_\_\_ Representative: \_\_\_\_\_

\_\_\_\_\_ Order no.: \_\_\_\_\_ Date: \_\_\_\_\_

Engineer: \_\_\_\_\_ Submitted by: \_\_\_\_\_ Date: \_\_\_\_\_

Contractor: \_\_\_\_\_ Approved by: \_\_\_\_\_ Date: \_\_\_\_\_

**Model:** 8 x 12M VTF      **Discharge head:** 8 x 20 F

**RPM:** 1770 Water lube

**750 GPM:** \_\_\_\_\_ T.D.H

- FM       UL       NFPA-20 only
- Approval     Construction
- Engine model: \_\_\_\_\_
- Ragd model: \_\_\_\_\_
- Shaft model: \_\_\_\_\_
- Controller model: \_\_\_\_\_

### NOTES

- Dimension based on randolph gear drive. May vary when driver adaptor is required.
- Dimensions are in inches unless otherwise indicated.
- Engine to base mounting and cooling loop to be field installed and plumbed.
- Engine oil & anti freeze/coolant may not be included.
- Gear shipped filled with oil. Check level before installation.
- Refer dwg. no. \_\_\_\_\_ for Engine dimensions.
- Not to be used for construction unless certified.

PRESS RATE	DISCHARGE FLANGE INCH (mm)					
	DA	DC	DD	DF	DG	DK
300 #	15.00 (381)	13.00 (330)	13.00 (330)	8.00 (203)	1.00 (25)	1.63 (41)



NO OF STG'S	DISCHARGE SIZE	RATING	RAGD	AG*	B	C	H*	I*	L	AA
	INCH (mm)		HP	INCH (mm)						
11	8.00 (203)	300	250	34.00 (863)	117.88 (2994)	1.69 (43)	13.75 (349)	21.75 (553)	—	—
12	8.00 (203)	300	250	34.00 (863)	127.25 (3232)	1.69 (43)	13.75 (349)	21.75 (553)	—	—
12	8.00 (203)	300	300	34.00 (863)	127.25 (3232)	1.69 (43)	13.75 (349)	21.75 (553)	—	—
13	8.00 (203)	300	250	34.00 (863)	136.63 (3470)	1.69 (43)	13.75 (349)	21.75 (553)	—	—
13	8.00 (203)	300	300	34.00 (863)	136.63 (3470)	1.69 (43)	13.75 (349)	21.75 (553)	—	—
14	8.00 (203)	300	300	34.00 (863)	145.00 (3683)	1.94 (49)	13.75 (349)	21.75 (553)	—	—
15	8.00 (203)	300	300	34.00 (863)	155.38 (3947)	1.94 (49)	13.75 (349)	21.75 (553)	—	—
15	8.00 (203)	300	350	36.00 (914)	155.38 (3947)	1.94 (49)	13.75 (349)	21.75 (553)	—	—
16	8.00 (203)	300	350	36.00 (914)	164.75 (4185)	1.94 (49)	13.75 (349)	21.75 (553)	—	—

\* Dimension based on randolph gear drive. May vary when driver adaptor is required.

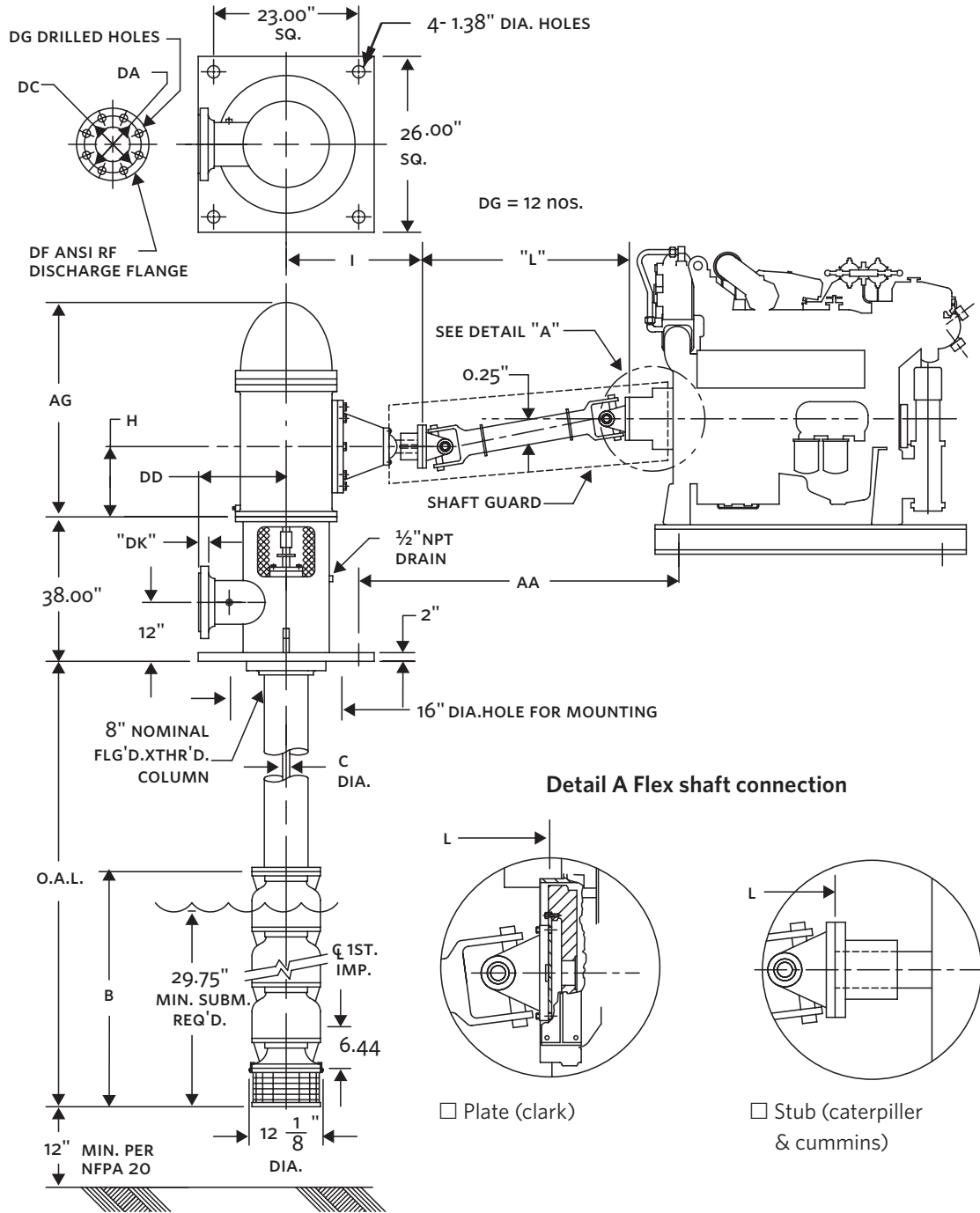

TORONTO  
+1 416 755 2291

BUFFALO  
+1 716 693 8813

DROITWICH SPA  
+44 8444 145 145

MANCHESTER  
+44 8444 145 145

BANGALORE  
+91 80 4906 3555

SHANGHAI  
+86 21 5237 0909

BEIJING  
+86 21 5237 0909

SÃO PAULO  
+55 11 4785 1330

LYON  
+33 4 20 10 26 21

DUBAI  
+971 4 887 6775

JIMBOLIA  
+40 256 360 030

FRANKFURT  
+49 6173 999 77 55