

VERTICAL TURBINE DIESEL FIRE PUMP | 8x12M VTF WITH 8x12 CAST IRON HEAD | SUBMITTAL

File No: F51.606
Date: APRIL 10, 2025
Supersedes: F51.606
Date: JULY 15, 2013

Job: _____ Representative: _____

_____ Order no.: _____ Date: _____

Engineer: _____ Submitted by: _____ Date: _____

Contractor: _____ Approved by: _____ Date: _____

Model: 8 x 12M VTF **Discharge head:** 8 x 12 A

RPM: 1770 Water lube

750 GPM: _____ T.D.H

- FM UL NFPA-20 only
- Approval Construction
- Engine model: _____
- Ragd model: _____
- Shaft model: _____
- Controller model: _____

NOTES

- Dimension based on randolph gear drive. May vary when driver adaptor is required.
- Dimensions are in inches unless otherwise indicated.
- Engine to base mounting and cooling loop to be field installed and plumbed.
- Engine oil & anti freeze/coolant may not be included.
- Gear shipped filled with oil. Check level before installation.
- Refer dwg. no. _____ for Engine dimensions.
- Not to be used for construction unless certified.

PRESS RATE	DISCHARGE FLANGE INCH (mm)					
	DA	DC	DD	DF	DG	DK
125 #	13.50 (343)	11.75 (299)	10.25 (260)	8.00 (203)	0.88 (22)	1.13 (29)



NO OF STG'S	DISCHARGE SIZE	RATING	RAGD	AG*	B	C	H*	I*	L	AA
	INCH (mm)		HP	INCH (mm)						
3	8 (203)	125	60-80	22.25 (565)	49.88 (1267)	1.25 (32)	8.50 (216)	17.00 (432)	—	—
4	8 (203)	125	60-80-100	22.25 (565)	59.25 (1505)	1.25 (32)	8.50 (216)	17.00 (432)	—	—
5	8 (203)	125	80-100	22.25 (565)	68.63 (1743)	1.25 (32)	8.50 (216)	17.00 (432)	—	—
5	8 (203)	125	100	26.69 (678)	68.63 (1743)	1.25 (32)	11.44 (291)	18.00 (457)	—	—

* Dimension based on randolph gear drive. May vary when driver adaptor is required.

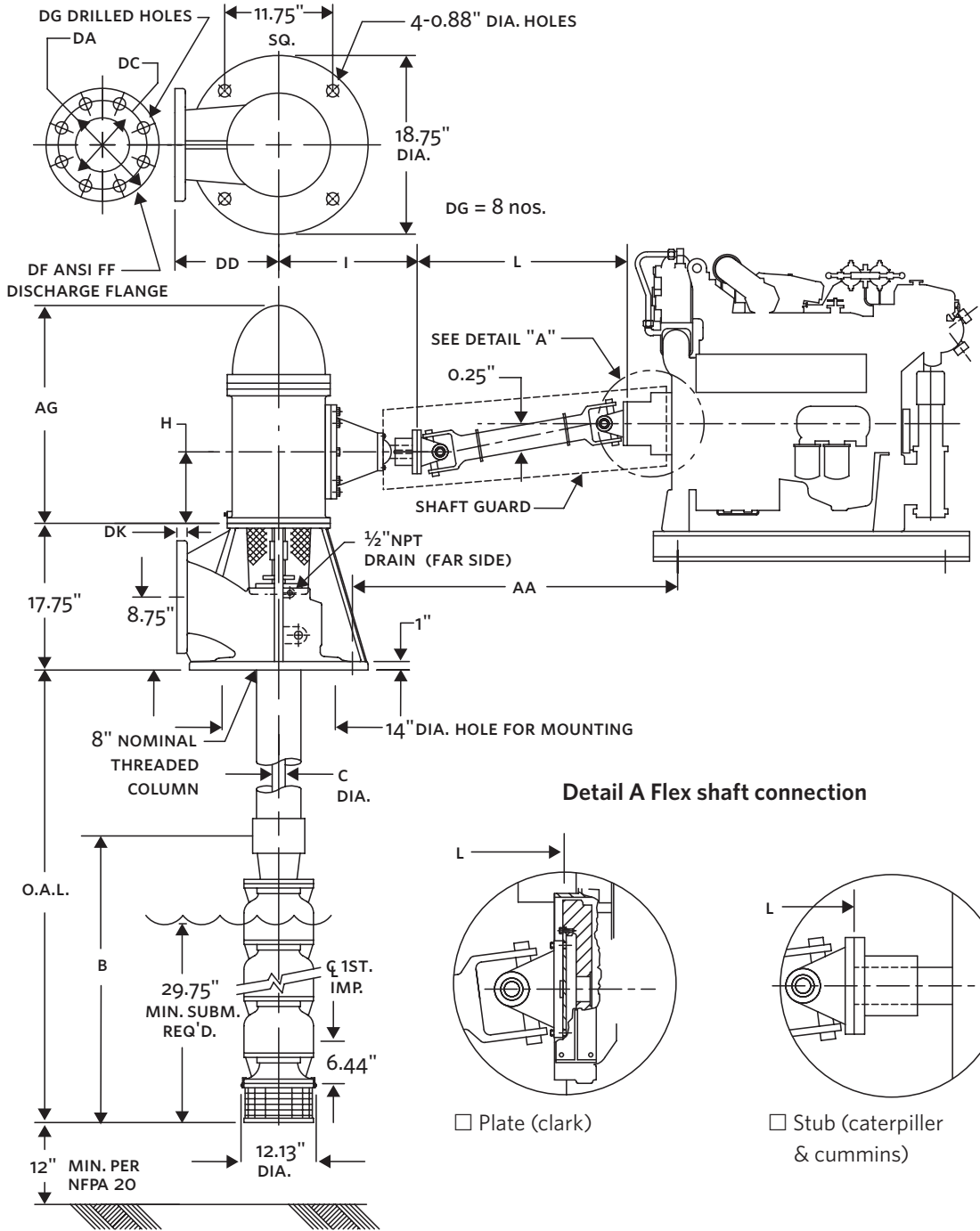

TORONTO
+1 416 755 2291

BUFFALO
+1 716 693 8813

DROITWICH SPA
+44 8444 145 145

MANCHESTER
+44 8444 145 145

BANGALORE
+91 80 4906 3555

SHANGHAI
+86 21 5237 0909

BEIJING
+86 21 5237 0909

SÃO PAULO
+55 11 4785 1330

LYON
+33 4 20 10 26 21

DUBAI
+971 4 887 6775

JIMBOLIA
+40 256 360 030

FRANKFURT
+49 6173 999 77 55