

VERTICAL TURBINE DIESEL FIRE PUMP | 4×8H VTF WITH 4×10 CAST IRON HEAD | SUBMITTAL

File No: F51.600
Date: APRIL 10, 2025
Supersedes: F51.600
Date: JULY 15, 2013

Job: _____ Representative: _____

_____ Order no.: _____ Date: _____

Engineer: _____ Submitted by: _____ Date: _____

Contractor: _____ Approved by: _____ Date: _____

Model: 4 × 8H VTF **Discharge head:** 4 × 10 A

RPM: 1770 Water lube

250 GPM: _____ T.D.H

- FM UL NFPA-20 only
- Approval Construction
- Engine model: _____
- RAGD model: _____
- Shaft model: _____
- Controller model: _____

NOTES

- Dimension based on randolph gear drive. May vary when driver adaptor is required.
- Dimensions are in inches unless otherwise indicated.
- Engine to base mounting and cooling loop to be field installed and plumbed.
- Engine oil & anti freeze/coolant may not be included.
- Gear shipped filled with oil. Check level before installation.
- Refer dwg. no. _____ for Engine dimensions.
- Not to be used for construction unless certified.

PRESS RATE	DISCHARGE FLANGE inch (mm)					
	DA	DC	DD	DF	DG	DK
125 #	9.00 (228)	7.50 (190)	8.63 (219)	4.00 (102)	0.75 (19)	0.94 (24)
250#	10.00 (254)	7.88 (200)	8.94 (227)	4.00 (102)	8.88 (226)	1.25 (32)



NO OF STG'S	DISCHARGE SIZE inch (mm)	RATING	RAGD HP	AG*	B	C	H*	I*	L	AA
				inch (mm)						
5	4 (102)	125	40	22.25 (565)	53.05 (1348)	1.00 (25)	8.50 (216)	17.00 (432)	—	—
6	4 (102)	125	40	22.25 (565)	60.75 (1543)	1.00 (25)	8.50 (216)	17.00 (432)	—	—
7	4 (102)	125	40	22.25 (565)	68.00 (1727)	1.00 (25)	8.50 (216)	17.00 (432)	—	—
8	4 (102)	125	40	22.25 (565)	75.25 (1911)	1.00 (25)	8.50 (216)	17.00 (432)	—	—
9	4 (102)	125	40	22.25 (565)	82.50 (2096)	1.00 (25)	8.50 (216)	17.00 (432)	—	—
10	4 (102)	125	40	22.25 (565)	89.75 (2280)	1.00 (25)	8.50 (216)	17.00 (432)	—	—
11	4 (102)	125	40	22.25 (565)	97.00 (2464)	1.00 (25)	8.50 (216)	17.00 (432)	—	—
11	4 (102)	250	40	22.25 (565)	97.00 (2464)	1.00 (25)	8.50 (216)	17.00 (432)	—	—
12	4 (102)	250	40	22.25 (565)	104.25 (2648)	1.00 (25)	8.50 (216)	17.00 (432)	—	—
13	4 (102)	250	40-60	22.25 (565)	111.50 (2832)	1.00 (25)	8.50 (216)	17.00 (432)	—	—
14	4 (102)	250	60	22.25 (565)	118.75 (3016)	1.00 (25)	8.50 (216)	17.00 (432)	—	—

* Dimension based on randolph gear drive. May vary when driver adaptor is required.

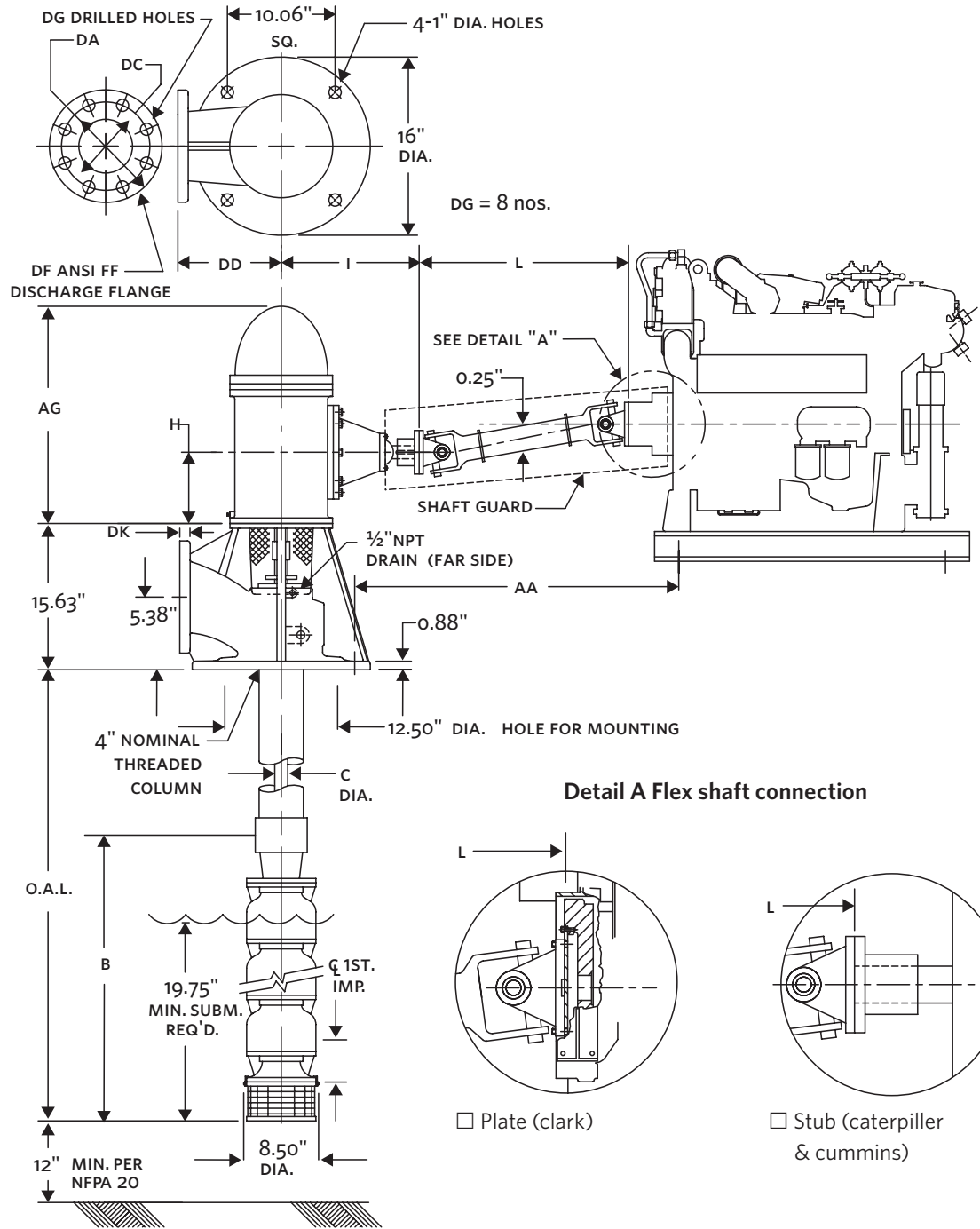

TORONTO
+1 416 755 2291

BUFFALO
+1 716 693 8813

DROITWICH SPA
+44 8444 145 145

MANCHESTER
+44 8444 145 145

BANGALORE
+91 80 4906 3555

SHANGHAI
+86 21 5237 0909

BEIJING
+86 21 5237 0909

SÃO PAULO
+55 11 4785 1330

LYON
+33 4 20 10 26 21

DUBAI
+971 4 887 6775

JIMBOLIA
+40 256 360 030

FRANKFURT
+49 6173 999 77 55