



FILE NO: 100.526
 DATE: Feb. 18, 2009
 SUPERSEDES: 100.526
 DATE: Feb. 9, 2009

Series 4300 IVS Design Envelope
Models: 08FG4, 08FH4, 08FI4

08F_4

SUBMITTAL

JOB: _____ REPRESENTATIVE: _____

 ENGINEER: _____ ORDER NO: _____ DATE: _____
 SUBMITTED BY: _____ DATE: _____
 CONTRACTOR: _____ APPROVED BY: _____ DATE: _____

| PUMP DESIGN DATA | | | |
|------------------|-------------|-------------------|---------|
| NO. OF PUMPS: | | | |
| TAG: | | | |
| CAPACITY: | USgpm (L/s) | HEAD: | ft. (m) |
| LIQUID: | | VISCOSITY: | |
| TEMPERATURE: | °F (°C) | SPECIFIC GRAVITY: | |

| MOTOR DESIGN DATA | | |
|-----------------------------------|--------------|------------------------|
| HP: | | |
| FRAME SIZE: | ENCLOSURE: | |
| VOLTS: | HERTZ: 60 Hz | PHASE: 3 |
| EFFICIENCY: NEMA PREMIUM | | |
| FLANGE SIZE: SUCTION: 6" (150 mm) | | DISCHARGE: 6" (150 mm) |

| DESIGN ENVELOPE CAPABILITY DATA | | | | | |
|---------------------------------|---------------------|----------------|------|-------------|------|
| MODEL | FLOW Usqpm (Lps) | HEAD ft (m) | EFF% | MOTOR HP | RPM |
| <input type="checkbox"/> 08FG4 | 653 (41.2) | 20 (6.0) | 83.7 | 7.5 | 1135 |
| <input type="checkbox"/> 08FH4 | 789 (49.7) | 29 (8.8) | 83.7 | 10 | 1375 |
| <input type="checkbox"/> 08FI4 | 1022 (64.5) | 49 (14.8) | 83.7 | 15 | 1777 |

| DRIVE DATA | |
|--|---|
| SENSORLESS CONTROL: | <input type="checkbox"/> REQUIRED <input type="checkbox"/> NOT REQUIRED |
| *MINIMUM SYSTEM PRESSURE TO BE MAINTAINED _____ ft (m) | |
| FIELD BUS PROTOCOL: <input type="checkbox"/> ModBUS RTU (standard) <input type="checkbox"/> LonWorks <input type="checkbox"/> BACnet | |
| ENCLOSURE: UL Type 12 | |
| EMI/RFI CONTROL: Integrated Filter designed to meet EN61800-3 | |
| HARMONIC SUPPRESSION: Integrated DC Link Reactors (<5% THD) | |
| COOLING: Fan-cooled through back channel | |
| AMBIENT TEMPERATURE: -10°C to +45°C up to 1000 meters above sea level (-14°F TO +113°F, 3280ft) | |
| ANALOG INPUTS: 2, current or voltage | |
| ANALOG OUTPUTS: 1, current | |
| DIGITAL INPUTS: 4 Programmable | |
| DIGITAL OUTPUTS: 2 Programmable (can be configured as additional digital inputs) | |
| PULSE INPUTS: 2 Programmable | |
| RELAY OUTPUTS: 2 Programmable | |
| COMMUNICATION PORT: RS 485 | |

| MATERIALS OF CONSTRUCTION | | |
|---------------------------|--|--------------|
| ANSI FLANGE RATING | <input type="checkbox"/> 125 lb. CAST IRON <input type="checkbox"/> 250 lb. DUCTILE IRON | |
| CONSTRUCTION | BF | DBF |
| CASING | CAST IRON | DUCTILE IRON |
| IMPELLER | BRONZE | BRONZE |
| FLUSH LINE | COPPER | COPPER |
| PUMP SHAFT | 416 STAINLESS STEEL | |
| COUPLING | HIGH TENSILE ALUMINUM | |
| GASKET | CONFINED NON-ASBESTOS | |

| MAXIMUM PUMP OPERATING CONDITIONS | |
|--|---|
| 125 lb. CAST IRON | 250 lb. DUCTILE IRON |
| 175 psig at 140°F (12 bars at 60°C) 100 psig at 300°F (7 bars at 149°C) | 375 psig at 100°F (26 bars at 38°C) 275 psig at 500°F (19 bars at 260°C) |
| SEE FILE NO. 43.50 FOR MAXIMUM SEAL OPERATING CONDITIONS | |

| MECHANICAL SEAL DESIGN DATA |
|--|
| See File No. 43.50 for standard mechanical Armstrong Seal Reference Number <input type="checkbox"/> C1 (a) Other _____ |

| SEAL DATA OPTIONS |
|-------------------|
| |

| OPTIONAL EQUIPMENT |
|--|
| |
| SEE FILE NO. 43.50 FOR ENVIRONMENTAL ACCESSORIES |

| CHASSIS SIZE: | | | | |
|---------------|-----|------------------|-----------|------|
| MODEL | hp | VFD Chassis Size | | |
| | | 200V-240V | 380V-480V | 600V |
| 08FG4 | 7.5 | B1 | A5 | A5 |
| 08FH4 | 10 | B1 | A5 | A5 |
| 08FI4 | 15 | B1 | B1 | B1 |

*If minimum maintained system pressure is not known: Default to 40% of design head

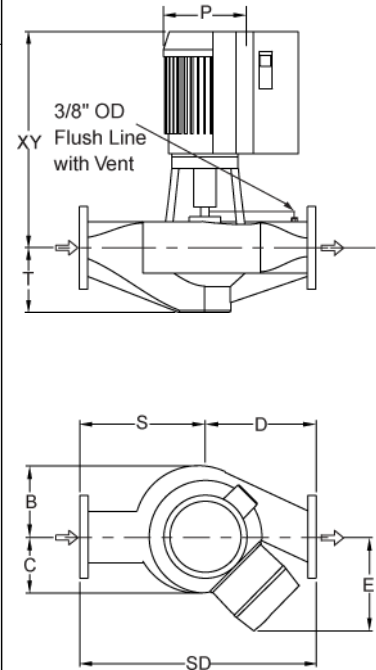
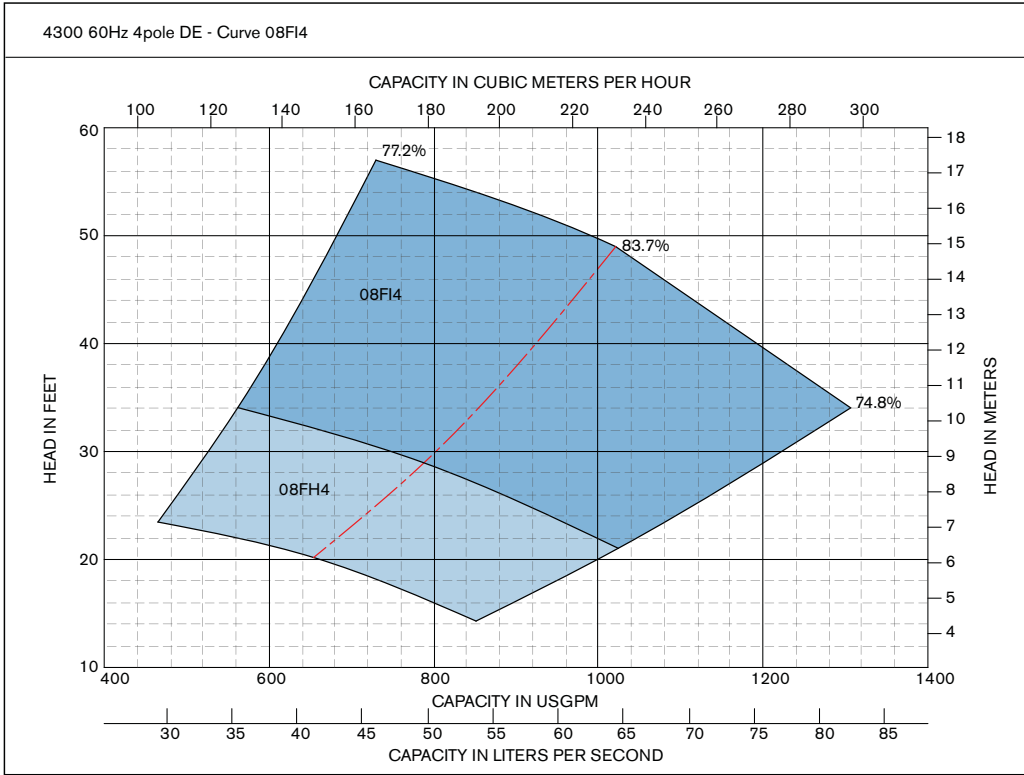

| DIMENSION DATA - inches (mm) | | | | | | | | | | | | | | |
|------------------------------|-------|------------|-------------|-------|------------|------------|-------------|-------------|-------------|-------------|-------------|-------------|-------------|-----------------|
| Curve No. | Size | Power (HP) | Motor Frame | | B | C | D | S | T | SD | E Max | P | XY | Weight lbs (Kg) |
| | | | ODP | TEFC | | | | | | | | | | |
| 08FG4 | 6x6x8 | 7.5 | 213TC | 213TC | 9.75 (248) | 7.50 (191) | 13.50 (343) | 19.50 (495) | 10.38 (264) | 33.00 (838) | 16.59 (421) | 11.25 (286) | 29.76 (756) | 490 (223) |
| 08FH4 | 6x6x8 | 10 | 215TC | 215TC | 9.75 (248) | 7.50 (191) | 13.50 (343) | 19.50 (495) | 10.38 (264) | 33.00 (838) | 16.59 (421) | 11.25 (286) | 29.76 (756) | 505 (230) |
| 08FI4 | 6x6x8 | 15 | 254TC | 254TC | 9.75 (248) | 7.50 (191) | 13.50 (343) | 19.50 (495) | 10.38 (264) | 33.00 (838) | 17.42 (442) | 13.38 (340) | 34.70 (881) | 575 (261) |

- COUPLING GUARD (NOT SHOWN) IS SUPPLIED.
- TOLERANCE OF $\pm 0.125"$ (± 3 mm) SHOULD BE USED.
- FOR EXACT INSTALLATION DATA PLEASE WRITE FACTORY FOR CERTIFIED DIMENSIONS.
- PUMP EQUIPPED WITH CASING DRAIN PLUG AND 1/4" NPT SUCTION AND DISCHARGE GAUGE PORTS

S. A. Armstrong Limited
23 Bertrand Avenue
Toronto, Ontario
Canada, M1L 2P3
T: (416) 755-2291
F (Main): (416) 759-9101

Armstrong Pumps Inc.
93 East Avenue
North Tonawanda, New York
U.S.A. 14120-6594
T: (716) 693-8813
F: (716) 693-8970

Armstrong Holden Brooke Pullen
Wenlock Way
Manchester
United Kingdom, M12 5JL
T: +44 (0) 1612 232223
F: +44 (0) 1612 209660



© S.A. Armstrong Limited 2009