

## Contents

<b>1 How to Read these Operating Instructions</b>	<b>5</b>
Copyright, limitation of liability and revision rights	5
<b>2 Safety</b>	<b>9</b>
High voltage warning	9
Safety Instructions	9
General Warning	9
Before commencing repair work	10
Special conditions	10
Avoid unintended start	11
Safe Stop of the frequency converter	11
IT mains	13
<b>3 Mechanical Installation</b>	<b>15</b>
How to Get Started	15
Pre-installation	15
Planning the Installation Site	15
Receiving the Frequency Converter	16
Transportation and Unpacking	16
Lifting	17
Mechanical Dimensions	19
Rated Power	25
Mechanical Installation	27
Terminal Locations - Frame size D	29
Terminal Locations - Frame size E	31
Terminal Locations - Frame size F	35
Cooling and Airflow	37
Field Installation of Options	44
Installation of Duct Cooling Kit in Rittal Enclosures	44
Outside Installation/ NEMA 3R Kit for Rittal Enclosures	45
Installation on Pedestal	46
Installation of Input Plate Options	47
Installation of Mains Shield for Frequency Converters	47
Frame size F Panel Options	48
Frame Size F Panel Options	48
<b>4 Electrical Installation</b>	<b>51</b>
Electrical Installation	51
Power Connections	51
Mains Connection	65
Fuses	66

Motor Insulation	69
Motor Bearing Currents	69
Control Cable Routing	71
Electrical Installation, Control Terminals	72
Connection Examples	74
Start/Stop	74
Pulse Start/Stop	74
Electrical Installation - additional	76
Electrical Installation, Control Cables	76
Switches S201, S202, and S801	78
Final Set-up and Test	79
Additional Connections	81
Mechanical Brake Control	81
Motor Thermal Protection	81
<b>5 How to Operate the Frequency Converter</b>	<b>83</b>
How to operate graphical LCP (GLCP)	83
Tips and tricks	90
<b>6 How to Programme</b>	<b>93</b>
Quick Menu mode	95
Function Setups	101
Parameter lists	130
Main Menu Structure	130
0-** Operation and Display	131
1-** Load / Motor	133
2-** Brakes	134
3-** Reference / Ramps	134
4-** Limits / Warnings	135
5-** Digital In / Out	136
6-** Analog In / Out	137
8-** Communication and Options	138
9-** Profibus	139
10-** CAN Fieldbus	140
11-** LonWorks	140
13-** Smart Logic Controller	141
14-** Special Functions	142
15-** FC Information	143
16-** Data Readouts	145
18-** Info & Readouts	147
20-** FC Closed Loop	148
21-** Ext. Closed Loop	149

22-** Application Functions	151
23-** Time Based Funtions	152
24-** Application Functions 2	153
25-** Cascade Pack Controller	154
26-** Analog I / O Option MCB 109	155
<b>7 General Specifications</b>	<b>157</b>
<b>8 Warnings and Alarms</b>	<b>171</b>
Alarms and Warnings	171
Fault messages	175
<b>Index</b>	<b>181</b>

**1**

# 1 How to Read these Operating Instructions

# 1

## 1.1.1 Copyright, limitation of liability and revision rights

This publication contains information proprietary to Armstrong. By accepting and using this manual the user agrees that the information contained herein will be used solely for operating equipment from Armstrong or equipment from other vendors provided that such equipment is intended for communication with Armstrong equipment over a serial communication link. This publication is protected under the Copyright laws of Denmark and most other countries.

Armstrong does not warrant that a software program produced according to the guidelines provided in this manual will function properly in every physical, hardware or software environment.

Although Armstrong has tested and reviewed the documentation within this manual, Armstrong makes no warranty or representation, neither expressed nor implied, with respect to this documentation, including its quality, performance, or fitness for a particular purpose.

In no event shall Armstrong be liable for direct, indirect, special, incidental, or consequential damages arising out of the use, or the inability to use information contained in this manual, even if advised of the possibility of such damages. In particular, Armstrong is not responsible for any costs, including but not limited to those incurred as a result of lost profits or revenue, loss or damage of equipment, loss of computer programs, loss of data, the costs to substitute these, or any claims by third parties.

Armstrong reserves the right to revise this publication at any time and to make changes to its contents without prior notice or any obligation to notify former or present users of such revisions or changes.

1

### 1.1.2 Symbols

Symbols used in this manual:

	<b>NB!</b> Indicates something to be noted by the reader.
---	--

	Indicates a general warning.
---	------------------------------

	Indicates a high-voltage warning.
---	-----------------------------------

*	Indicates default setting
---	---------------------------

### 1.1.3 Available literature for IVS 102

- Operating Instructions MG.12.Ex.yy provide the necessary information for getting the frequency converter up and running.
- Design Guide MG.12.Rx.yy entails all technical information about the frequency converter and customer design and applications.
- Programming Guide MG.12.Fx.yy provides information on how to programme and includes complete parameter descriptions.

x = Revision number

yy = Language code

Armstrong technical literature is available in print from your local Armstrong Sales Office

1.1.4 Abbreviations and standards

Abbreviations:	Terms:	SI-units:	I-P units:
a	Acceleration	m/s <sup>2</sup>	ft/s <sup>2</sup>
AWG	American wire gauge		
Auto Tune	Automatic Motor Tuning		
°C	Celsius		
I	Current	A	Amp
I <sub>LIM</sub>	Current limit		
Joule	Energy	J = N•m	ft-lb, Btu
°F	Fahrenheit		
FC	Frequency Converter		
f	Frequency	Hz	Hz
kHz	Kilohertz	kHz	kHz
LCP	Local Control Panel		
mA	Milliampere		
ms	Millisecond		
min	Minute		
MCT	Motion Control Tool		
M-TYPE	Motor Type Dependent		
Nm	Newton Metres		in-lbs
I <sub>M,N</sub>	Nominal motor current		
f <sub>M,N</sub>	Nominal motor frequency		
P <sub>M,N</sub>	Nominal motor power		
U <sub>M,N</sub>	Nominal motor voltage		
par.	Parameter		
PELV	Protective Extra Low Voltage		
Watt	Power	W	Btu/hr, hp
Pascal	Pressure	Pa = N/m <sup>2</sup>	psi, psf, ft of water
I <sub>INV</sub>	Rated Inverter Output Current		
RPM	Revolutions Per Minute		
SR	Size Related		
T	Temperature	C	F
t	Time	s	s,hr
T <sub>LIM</sub>	Torque limit		
U	Voltage	V	V

Table 1.1: Abbreviation and standards table .



2



## 2 Safety

### 2.1.1 High voltage warning



The voltage of the frequency converter and the MCO 101 option card is dangerous whenever it is connected to mains. Incorrect installation of the motor or frequency converter may cause death, serious injury or damage to the equipment. Consequently, it is essential to comply with the instructions in this manual as well as local and national rules and safety regulations.

### 2.1.2 Safety Instructions



Prior to using functions directly or indirectly influencing personal safety (e.g. **Safe Stop**, **Fire Mode** or other functions either forcing the motor to stop or attempting to keep it functioning) a thorough **risk analysis** and **system test** must be carried through. The system tests **must** include testing failure modes regarding the control signalling (analog and digital signals and serial communication).



**NB!**  
Before using **Fire Mode**, contact **Armstrong**

- Make sure the frequency converter is properly connected to earth.
- Do not remove mains connections, motor connections or other power connections while the frequency converter is connected to power.
- Protect users against supply voltage.
- Protect the motor against overloading according to national and local regulations.
- The earth leakage current exceeds 3.5 mA.
- The [OFF] key is not a safety switch. It does not disconnect the frequency converter from mains.

### 2.1.3 General Warning



**Warning:**

Touching the electrical parts may be fatal - even after the equipment has been disconnected from mains. Also make sure that other voltage inputs have been disconnected, (linkage of DC intermediate circuit), as well as the motor connection for kinetic back-up.

Before touching any potentially live parts of the frequency converter, wait at least as follows:

380 - 480 V, 110 - 250 kW, wait at least 20 minutes.

380 - 480 V, 315- 1000 kW, wait at least 40 minutes.

525 - 690 V, 45 - 400 kW, wait at least 20 minutes.

525 - 690 V, 450 - 1200 kW, wait at least 30 minutes.

Shorter time is allowed only if indicated on the nameplate for the specific unit.



**Leakage Current**

The earth leakage current from the frequency converter exceeds 3.5 mA. According to IEC 61800-5-1 a reinforced Protective Earth connection must be ensured by means of: a min. 10mm<sup>2</sup> Cu or 16mm<sup>2</sup> Al PE-wire or an additional PE wire - with the same cable cross section as the Mains wiring - must be terminated separately.

**Residual Current Device**

This product can cause a D.C. current in the protective conductor. Where a residual current device (RCD) is used for extra protection, only an RCD of Type B (time delayed) shall be used on the supply side of this product. See also RCD Application Note MN.90.GX.02. Protective earthing of the frequency converter and the use of RCD's must always follow national and local regulations.

2

### 2.1.4 Before commencing repair work

1. Disconnect the frequency converter from mains
2. Disconnect DC bus terminals 88 and 89
3. Wait at least the time mentioned in section General Warning above
4. Remove motor cable

### 2.1.5 Special conditions

**Electrical ratings:**

The rating indicated on the nameplate of the frequency converter is based on a typical 3-phase mains power supply, within the specified voltage, current and temperature range, which is expected to be used in most applications.

The frequency converters also support other special applications, which affect the electrical ratings of the frequency converter. Special conditions which affect the electrical ratings might be:

- Single phase applications
- High temperature applications which require de-rating of the electrical ratings
- Marine applications with more severe environmental conditions.

Other applications might also affect the electrical ratings.

Consult the relevant sections in this manual and in the for information about the electrical ratings.

**Installation requirements:**

The overall electrical safety of the frequency converter requires special installation considerations regarding:

- Fuses and circuit breakers for over-current and short-circuit protection
- Selection of power cables (mains, motor, brake, loadsharing and relay)
- Grid configuration (grounded delta transformer leg, IT, TN, etc.)
- Safety of low-voltage ports (PELV conditions).

Consult the relevant clauses in these instructions and in the for information about the installation requirements.

### 2.1.6 Caution



The frequency converter's DC link capacitors remain charged after power has been disconnected. To avoid an electrical shock hazard, disconnect the frequency converter from the mains before carrying out maintenance. Before doing service on the frequency converter, wait at least the amount of time indicated below:

Voltage	Power size	Min. Waiting Time
380 - 480 V	110 - 250 kW	20 minutes
	315 - 1000 kW	40 minutes
525 - 690 V	45 - 400 kW	20 minutes
	450- 1200 kW	30 minutes

Be aware that there may be high voltage on the DC link even when the LEDs are turned off.

### 2.1.7 Installation at High Altitudes (PELV)



**Installation at high altitude:**

380 - 480 V: At altitudes above 3 km, please contact Armstrong regarding PELV.

525 - 690 V: At altitudes above 2 km, please contact Armstrong regarding PELV.

2

### 2.1.8 Avoid unintended start



While the frequency converter is connected to mains, the motor can be started/stopped using digital commands, bus commands, references or via the Local Control Panel.

- Disconnect the frequency converter from mains whenever personal safety considerations make it necessary to avoid unintended start.
- To avoid unintended start, always activate the [OFF] key before changing parameters.
- Unless terminal 37 is turned off, an electronic fault, temporary overload, a fault in the mains supply, or lost motor connection may cause a stopped motor to start.

### 2.1.9 Safe Stop of the frequency converter

For versions fitted with a Safe Stop terminal 37 input, the frequency converter can perform the safety function *Safe Torque Off* (As defined by draft CD IEC 61800-5-2) or *Stop Category 0* (as defined in EN 60204-1).

It is designed and approved suitable for the requirements of Safety Category 3 in EN 954-1. This functionality is called Safe Stop. Prior to integration and use of Safe Stop in an installation, a thorough risk analysis on the installation must be carried out in order to determine whether the Safe Stop functionality and safety category are appropriate and sufficient. In order to install and use the Safe Stop function in accordance with the requirements of Safety Category 3 in EN 954-1, the related information and instructions of the must be followed! The information and instructions of the Operating Instructions are not sufficient for a correct and safe use of the Safe Stop functionality!

2

Prüf- und Zertifizierungsstelle  
im BG-PRÜFZERT



**BGIA**  
Berufsgenossenschaftliches  
Institut für Arbeitsschutz  
Hauptverband der gewerblichen  
Berufsgenossenschaften

**Type Test Certificate**

05 06004
----------

No. of certificate

**Translation**  
In any case, the German  
original shall prevail.

Name and address of the holder of the certificate: (customer) Danfoss Drives A/S, Ulhøes 1 DK-6300 Graasten, Danmark

Name and address of the manufacturer: Danfoss Drives A/S, Ulhøes 1 DK-6300 Graasten, Danmark

Ref. of customer:	Ref. of Test and Certification Body: Apf/Ksh VE-Nr. 2003 23220	Date of Issue: 13.04.2005
-------------------	---	------------------------------

Product designation: Frequency converter with integrated safety functions

Type: VLT® Automation Drive FC 302

Intended purpose: Implementation of safety function „Safe Stop“

Testing based on: EN 954-1, 1997-03,  
DKE AK 226.03, 1998-06,  
EN ISO 13849-2; 2003-12,  
EN 61800-3, 2001-02,  
EN 61800-5-1, 2003-09,

Test certificate: No.: 2003 23220 from 13.04.2005

Remarks: The presented types of the frequency converter FC 302 meet the requirements laid down in the test bases.  
With correct wiring a category 3 according to DIN EN 954-1 is reached for the safety function.

The type tested complies with the provisions laid down in the directive 98/37/EC (Machinery).

Further conditions are laid down in the Rules of Procedure for Testing and Certification of April 2004.

Head of certification body  
  
(Prof. Dr. rer. nat. Dietmar Reinert)

Certification officer  
  
(Dipl.-Ing. R. Apfeld)

PZB10E  
01.05



Postal address:  
53754 Sankt Augustin

Office:  
Alte Heerstraße 111  
53757 Sankt Augustin

Phone: 0 22 41/2 31-02  
Fax: 0 22 41/2 31-22 34

130BA491

### 2.1.10 IT mains



**IT mains**

Do not connect frequency converters with RFI-filters to mains supplies with a voltage between phase and earth of more than 440 V for 400 V converters and 760 V for 690 V converters.

For 400 V IT mains and delta earth (grounded leg), mains voltage may exceed 440 V between phase and earth.

For 690 V IT mains and delta earth (grounded leg), mains voltage may exceed 760 V between phase and earth.

2

Par. 14-50 *RFI Filter* can be used to disconnect the internal RFI capacitors from the RFI filter to ground.

### 2.1.11 Software Version and Approvals: IVS 102

**IVS 102**  
Software version: 3.2.x

This manual can be used with all IVS 102 frequency converters with software version 3.2.x.  
The software version number can be seen from par. 15-43 *Software Version*.

### 2.1.12 Disposal instruction

Equipment containing electrical components must not be disposed of together with domestic waste.  
It must be separately collected with electrical and electronic waste according to local and currently valid legislation.



**3**

## 3 Mechanical Installation

### 3.1 How to Get Started

#### 3.1.1 About How to Install

This chapter covers mechanical and electrical installations to and from power terminals and control card terminals. Electrical installation of *options* is described in the relevant Operating Instructions and Design Guide.

#### 3.1.2 How to Get Started

The frequency converter is designed to achieve a quick and EMC-correct installation by following the steps described below.



Read the safety instructions before installing the unit.

#### Mechanical Installation

- Mechanical mounting

#### Electrical Installation

- Connection to Mains and Protecting Earth
- Motor connection and cables
- Fuses and circuit breakers
- Control terminals - cables

#### Quick setup

- Local Control Panel, LCP
- Automatic Motor Adaptation, AMA
- Programming

Frame size is depending on enclosure type, power range and mains voltage

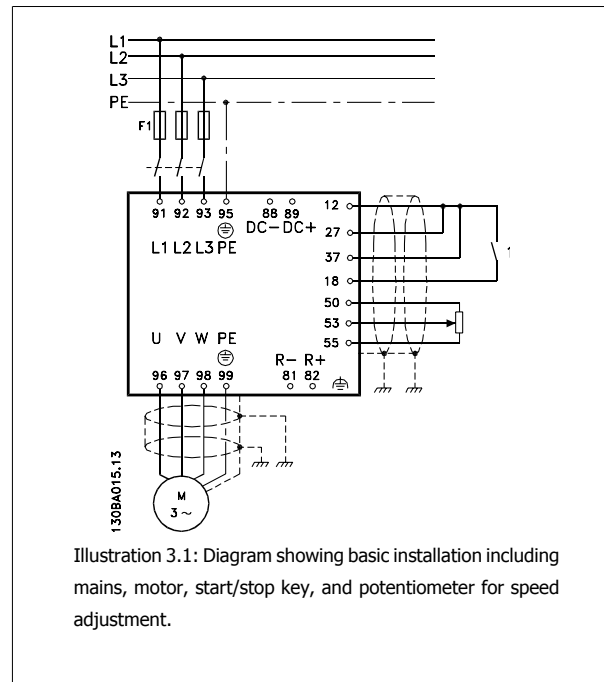

### 3.2 Pre-installation

#### 3.2.1 Planning the Installation Site



#### NB!

Before performing the installation it is important to plan the installation of the frequency converter. Neglecting this may result in extra work during and after installation.

Select the best possible operation site by considering the following (see details on the following pages, and the respective Design Guides):

- Ambient operating temperature
- Installation method
- How to cool the unit
- Position of the frequency converter
- Cable routing
- Ensure the power source supplies the correct voltage and necessary current
- Ensure that the motor current rating is within the maximum current from the frequency converter
- If the frequency converter is without built-in fuses, ensure that the external fuses are rated correctly.

### 3.2.2 Receiving the Frequency Converter

When receiving the frequency converter please make sure that the packaging is intact, and be aware of any damage that might have occurred to the unit during transport. In case damage has occurred, contact immediately the shipping company to claim the damage.

### 3.2.3 Transportation and Unpacking

Before unpacking the frequency converter it is recommended that it is located as close as possible to the final installation site. Remove the box and handle the frequency converter on the pallet, as long as possible.



**NB!**

The card box cover contains a drilling master for the mounting holes in the D frames. For the E size, please refer to section *Mechanical Dimensions* later in this chapter.

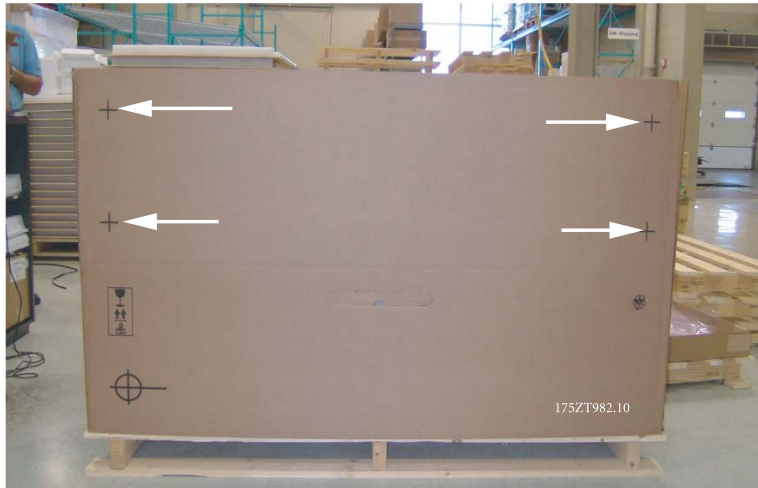

Illustration 3.2: Mounting Template



### 3.2.4 Lifting

Always lift the frequency converter in the dedicated lifting eyes. For all D and E2 (IP00) enclosures, use a bar to avoid bending the lifting holes of the frequency converter.

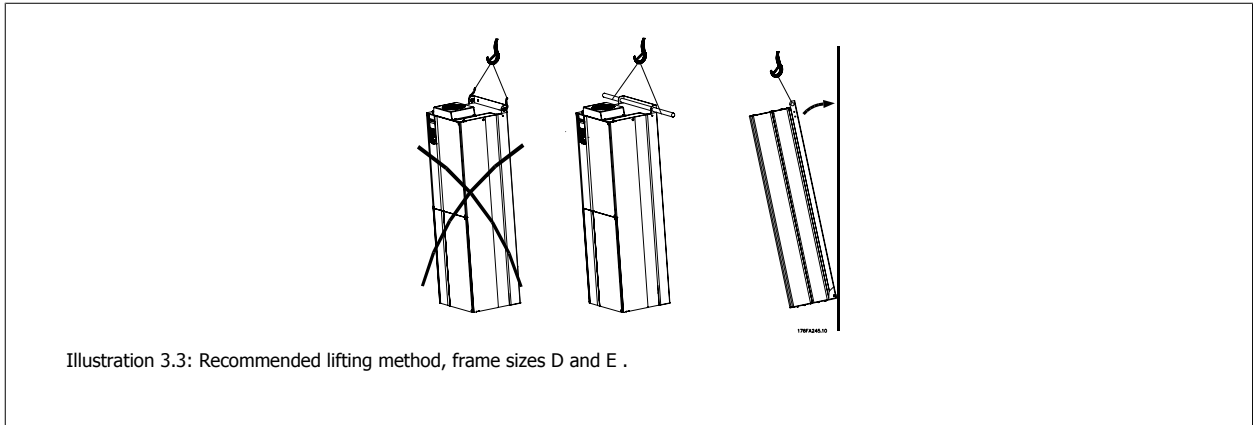

Illustration 3.3: Recommended lifting method, frame sizes D and E .



**NB!**

The lifting bar must be able to handle the weight of the frequency converter. See *Mechanical Dimensions* for the weight of the different frame sizes. Maximum diameter for bar is 2.5 cm (1 inch). The angle from the top of the drive to the lifting cable should be 60° C or greater.

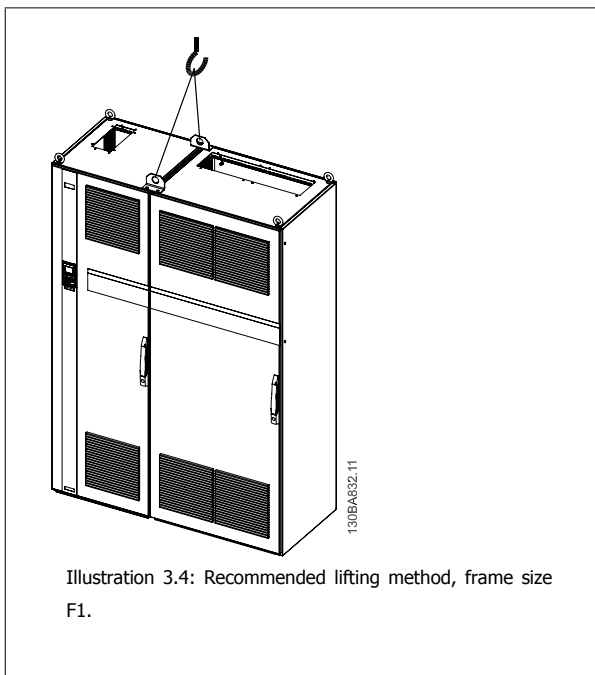

Illustration 3.4: Recommended lifting method, frame size F1.

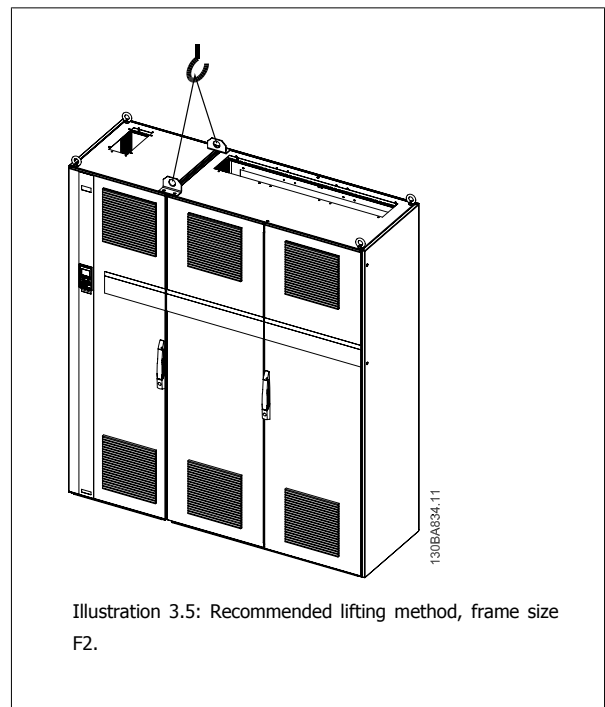

Illustration 3.5: Recommended lifting method, frame size F2.

3

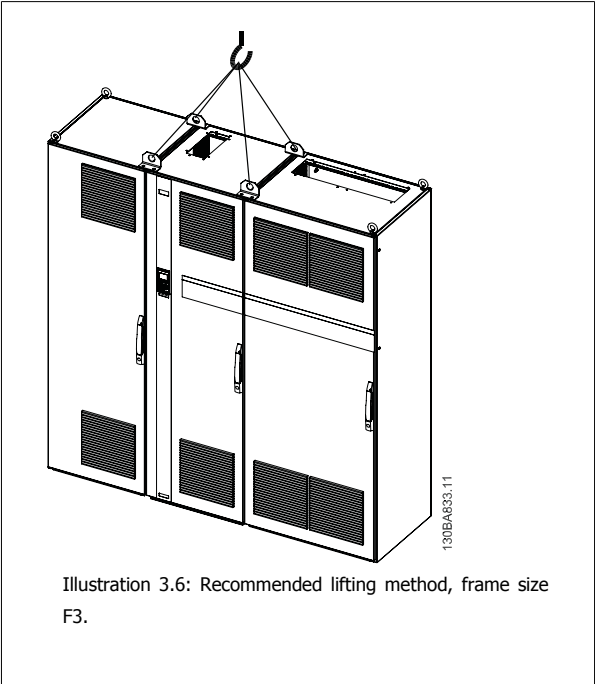

Illustration 3.6: Recommended lifting method, frame size F3.

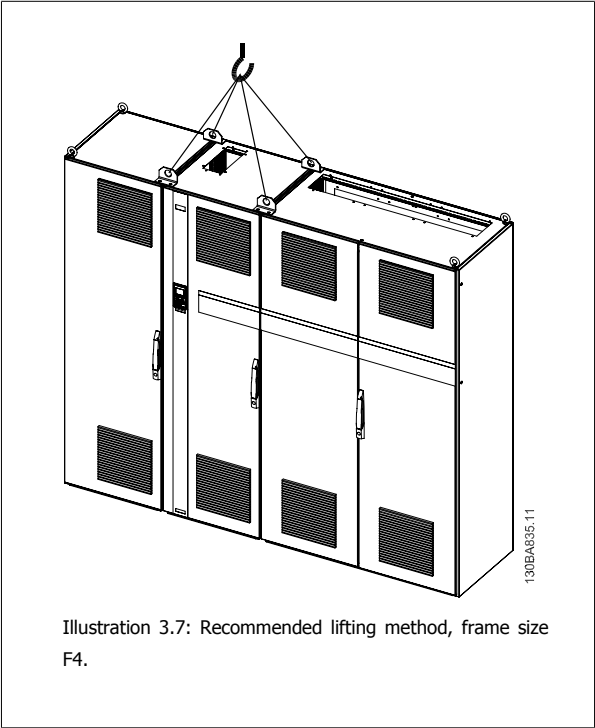
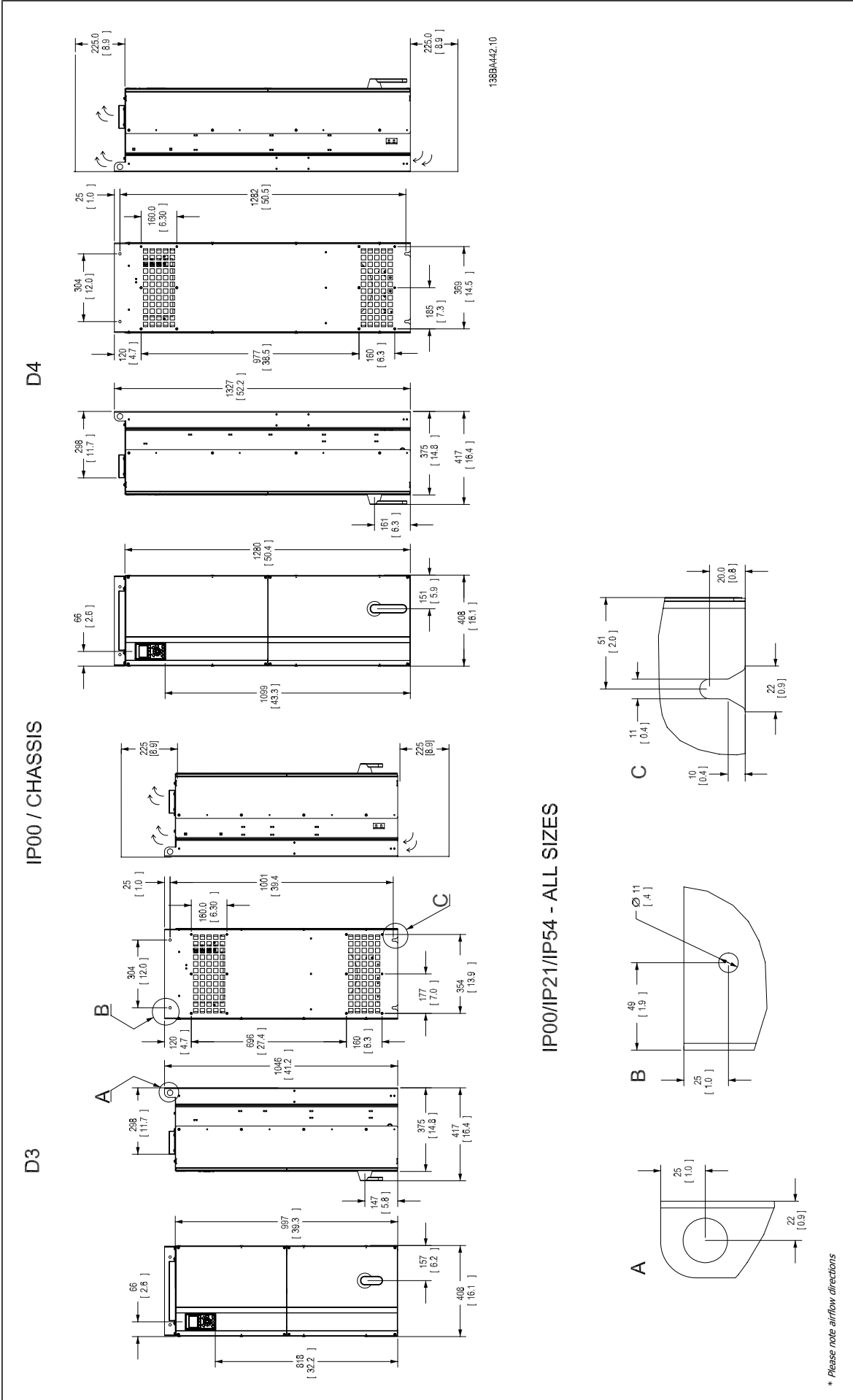

Illustration 3.7: Recommended lifting method, frame size F4.



3



IP21 AND IP54 / UL AND NEMA TYPE 1 AND 12

E1

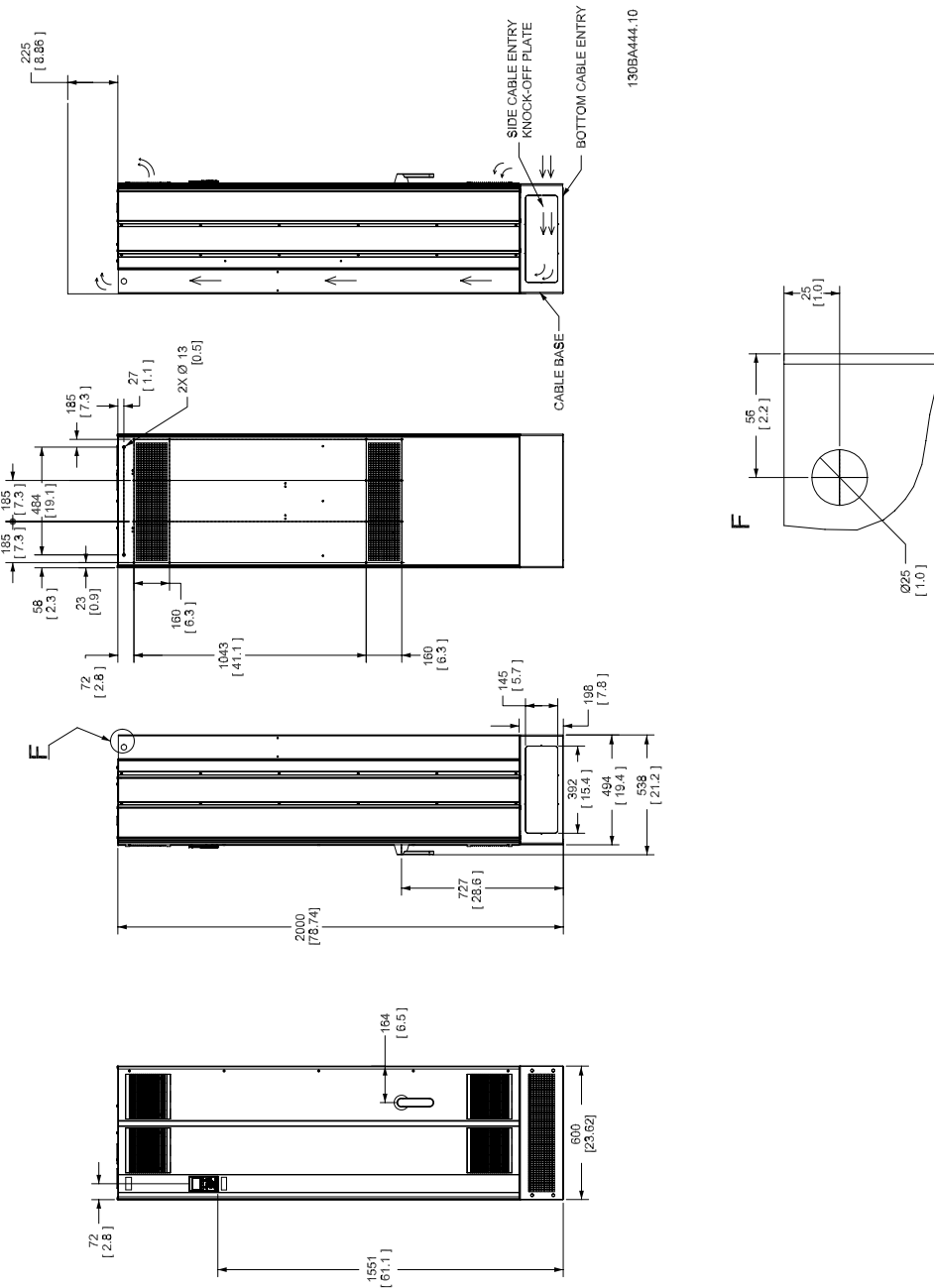

\* Please note airflow directions

3

IP00 / CHASSIS

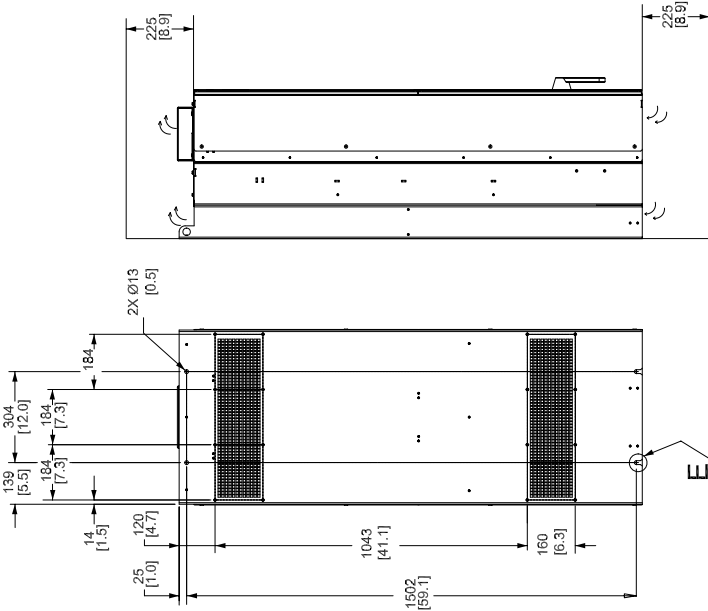

130BA445.10

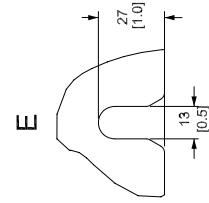

E2

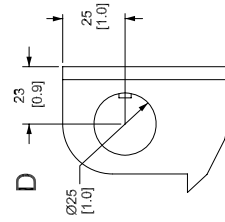
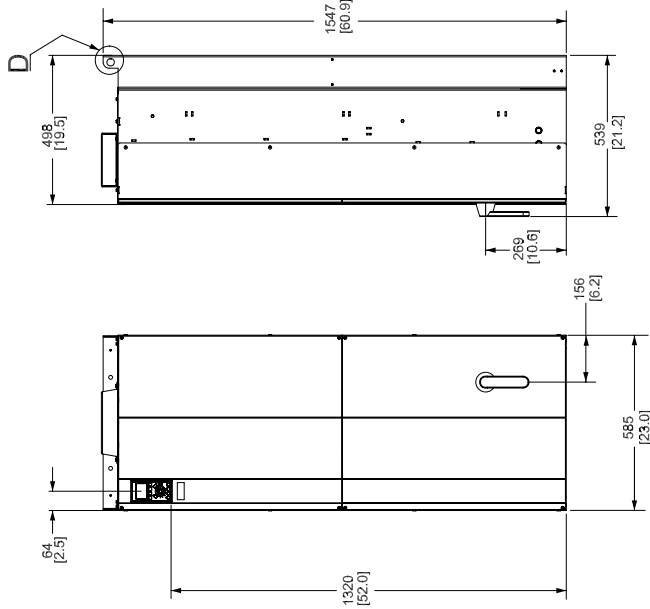

\* Please note airflow directions

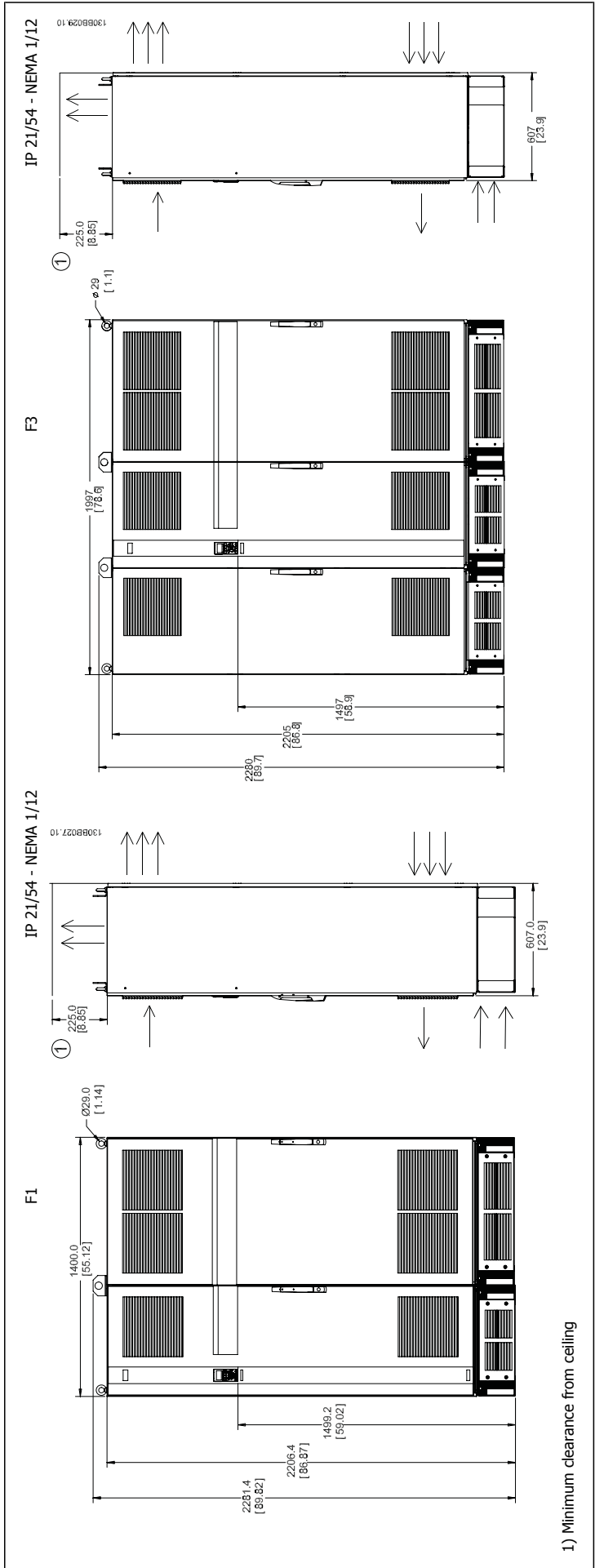

3

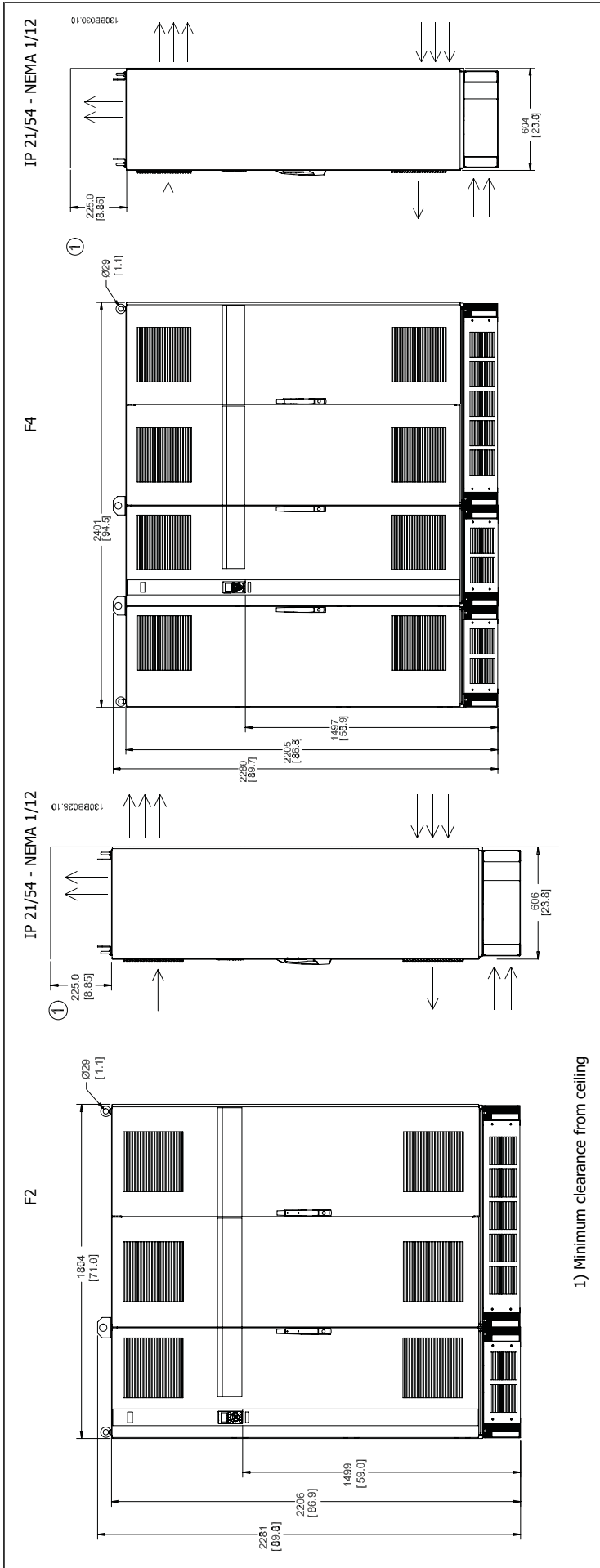

1) Minimum clearance from ceiling



Mechanical dimensions , Frame size D								
Frame Size		D1		D2		D3		D4
		110 - 132 kW at 400 V (380 - 480 V) 45 - 160 kW at 690 V (525-690 V)		160 - 250 kW at 400 V (380 - 480 V) 200 - 400 kW at 690 V (525-690 V)		110 - 132 kW at 400 V (380 - 480 V) 45 - 160 kW at 690 V (525-690 V)		160 - 250 kW at 400 V (380 - 480 V) 200 - 400 kW at 690 V (525-690 V)
IP NEMA		21 Type 1	54 Type 12	21 Type 1	54 Type 12	00 Chassis		00 Chassis
Shipping dimensions	Height	650 mm		650 mm		650 mm		650 mm
	Width	1730 mm		1730 mm		1220 mm		1490 mm
	Depth	570 mm		570 mm		570 mm		570 mm
Drive dimensions	Height	1209 mm		1589 mm		1046 mm		1327 mm
	Width	420 mm		420 mm		408 mm		408 mm
	Depth	380 mm		380 mm		375 mm		375 mm
	Max weight	104 kg		151 kg		91 kg		138 kg

Mechanical dimensions, frame size E and F							
Frame Size		E1	E2	F1	F2	F3	F4
		315 - 450 kW at 400 V (380 - 480 V) 450 - 630 kW at 690 V (525-690 V)	315 - 450 kW at 400 V (380 - 480 V) 450 - 630 kW at 690 V (525-690 V)	500 - 710 kW at 400 V (380 - 480 V) 710 - 900 kW at 690 V (525-690 V)	800 - 1000 kW at 400 V (380 - 480 V) 1000 - 1200 kW at 690 V (525-690 V)	500 - 710 kW at 400 V (380 - 480 V) 710 - 900 kW at 690 V (525-690 V)	800 - 1000 kW at 400 V (380 - 480 V) 1000 - 1200 kW at 690 V (525-690 V)
IP NEMA		21, 54 Type 1/ Type 12	00 Chassis	21, 54 Type 1/ Type 12	21, 54 Type 1/ Type 12	21, 54 Type 1/ Type 12	21, 54 Type 1/ Type 12
Shipping dimensions	Height	840 mm	831 mm	2324 mm	2324 mm	2324 mm	2324 mm
	Width	2197 mm	1705 mm	1569 mm	1962 mm	2159 mm	2559 mm
	Depth	736 mm	736 mm	927 mm	927 mm	927 mm	927 mm
Drive dimensions	Height	2000 mm	1547 mm	2204	2204	2204	2204
	Width	600 mm	585 mm	1400	1800	2000	2400
	Depth	494 mm	498 mm	606	606	606	606
	Max weight	313 kg	277 kg	1004	1246	1299	1541

**3.2.6 Rated Power**

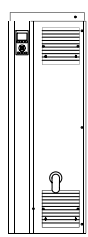
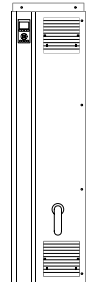
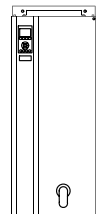
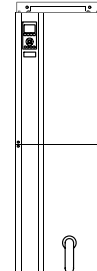
Frame size		D1	D2	D3	D4
		 130BA481.10	 130BA482.10	 130BA478.10	 130BA479.10
Enclosure protection	IP	21/54		00	00
	NEMA	Type 1/ Type 12		Chassis	
Normal overload rated power - 110% overload torque		110 - 132 kW at 400 V (380 - 480 V) 45 - 160 kW at 690 V (525-690 V)	150 - 250 kW at 400 V (380 - 480 V) 200 - 400 kW at 690 V (525-690 V)	110 - 132 kW at 400 V (380 - 480 V) 45 - 160 kW at 690 V (525-690 V)	150 - 250 kW at 400 V (380 - 480 V) 200 - 400 kW at 690 V (525-690 V)

3

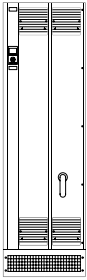
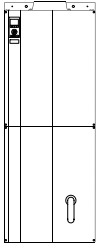
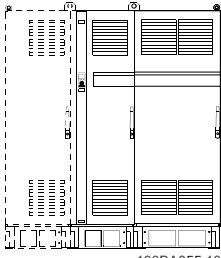
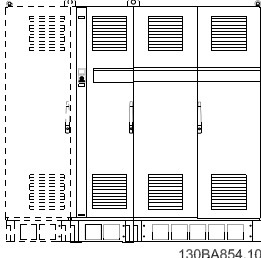
Frame size		E1	E2	F1/F3	F2/F4
		 130BA483.10	 130BA480.10	 130BA855.10	 130BA854.10
Enclosure protection	IP	21/54	00	21/54	21/54
	NEMA	Type 1/ Type 12	Chassis	Type 1/ Type 12	Type 1/ Type 12
Normal overload rated power - 110% overload torque		315 - 450 kW at 400 V (380 - 480 V) 450 - 630 kW at 690 V (525-690 V)	315 - 450 kW at 400 V (380 - 480 V) 450 - 630 kW at 690 V (525-690 V)	500 - 710 kW at 400 V (380 - 480 V) 710 - 900 kW at 690 V (525-690 V)	800 - 1000 kW at 400 V (380 - 480 V) 1000 - 1200 kW at 690 V (525-690 V)



**NB!**

The F frames have four different sizes, F1, F2, F3 and F4. The F1 and F2 consist of an inverter cabinet on the right and rectifier cabinet on the left. The F3 and F4 have an additional options cabinet left of the rectifier cabinet. The F3 is an F1 with an additional options cabinet. The F4 is an F2 with an additional options cabinet.

### 3.3 Mechanical Installation

Preparation of the mechanical installation of the frequency converter must be done carefully to ensure a proper result and to avoid additional work during installation. Start taking a close look at the mechanical drawings at the end of this instruction to become familiar with the space demands.

#### 3.3.1 Tools Needed

To perform the mechanical installation the following tools are needed:

- Drill with 10 or 12 mm drill
- Tape measure
- Wrench with relevant metric sockets (7-17 mm)
- Extensions to wrench
- Sheet metal punch for conduits or cable glands in IP 21/Nema 1 and IP 54 units
- Lifting bar to lift the unit (rod or tube max. Ø 25 mm (1 inch), able to lift minimum 400 kg (880 lbs)).
- Crane or other lifting aid to place the frequency converter in position
- A Torx T50 tool is needed to install the E1 in IP21 and IP54 enclosure types.

#### 3.3.2 General Considerations

##### Space

Ensure proper space above and below the frequency converter to allow airflow and cable access. In addition space in front of the unit must be considered to enable opening of the door of the panel.

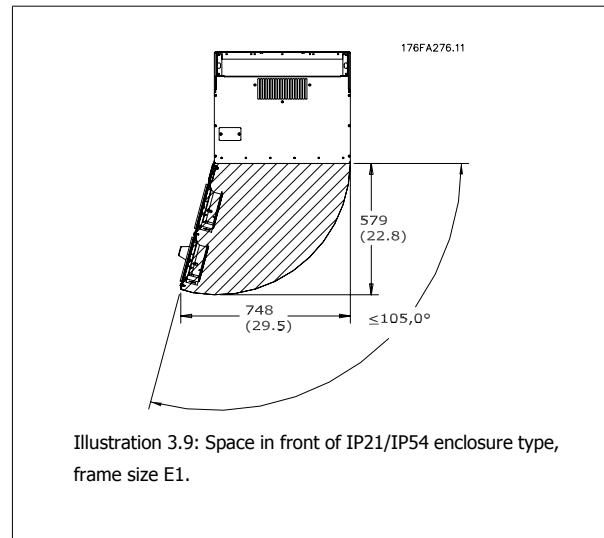
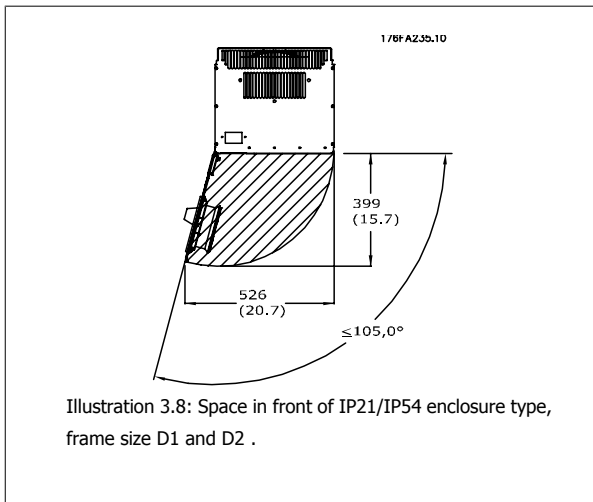

3

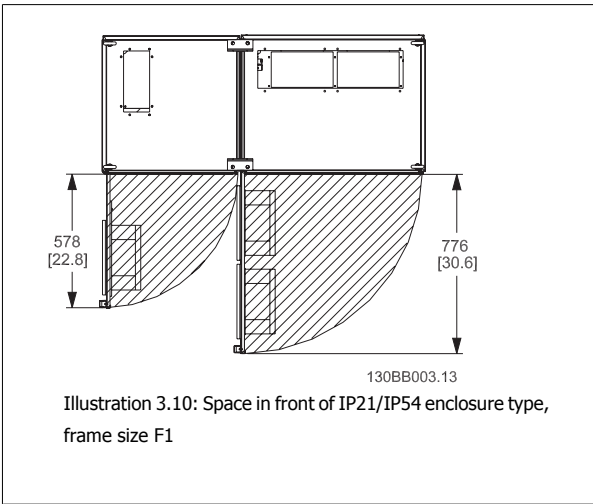

Illustration 3.10: Space in front of IP21/IP54 enclosure type, frame size F1

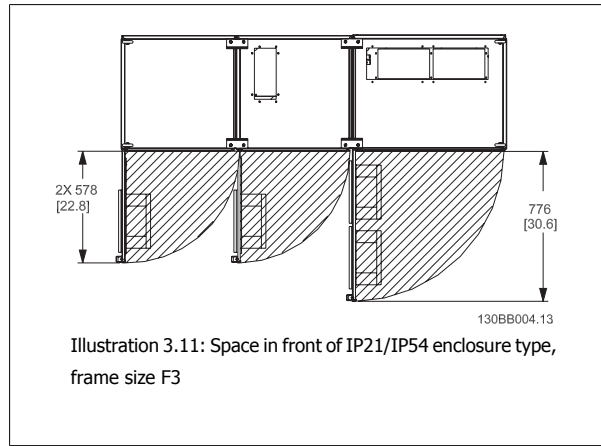

Illustration 3.11: Space in front of IP21/IP54 enclosure type, frame size F3

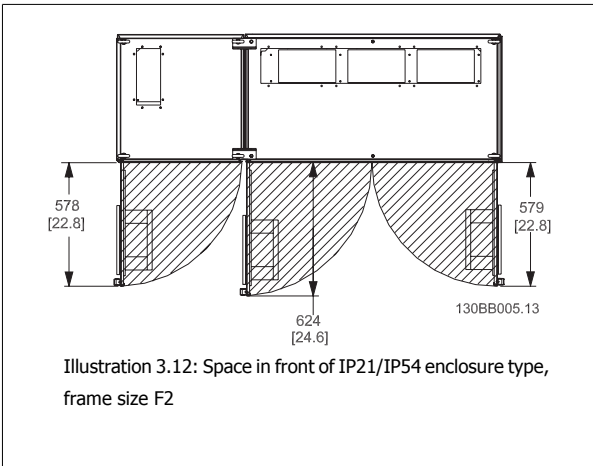

Illustration 3.12: Space in front of IP21/IP54 enclosure type, frame size F2

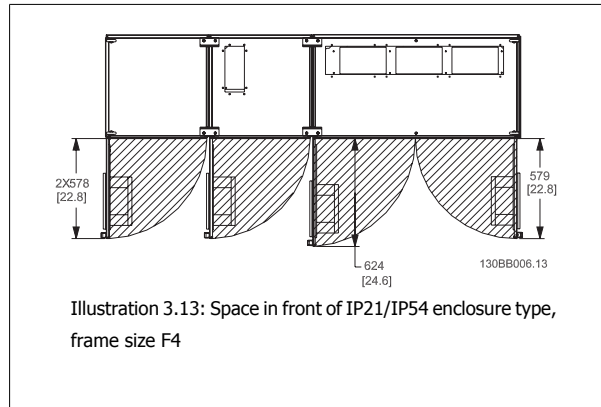

Illustration 3.13: Space in front of IP21/IP54 enclosure type, frame size F4

**Wire access**

Ensure that proper cable access is present including necessary bending allowance. As the IP00 enclosure is open to the bottom cables must be fixed to the back panel of the enclosure where the frequency converter is mounted, i.e. by using cable clamps.

**NB!**  
All cable lugs/ shoes must mount within the width of the terminal bus bar

### 3.3.3 Terminal Locations - Frame size D

Take the following position of the terminals into consideration when you design for cables access.

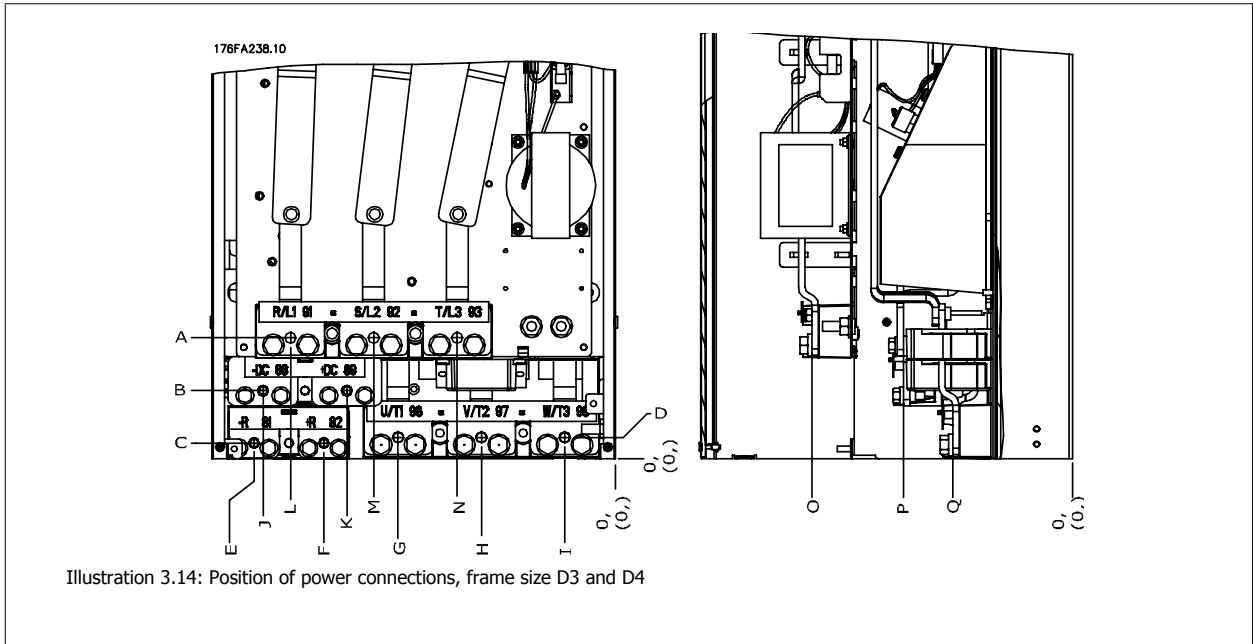

Illustration 3.14: Position of power connections, frame size D3 and D4

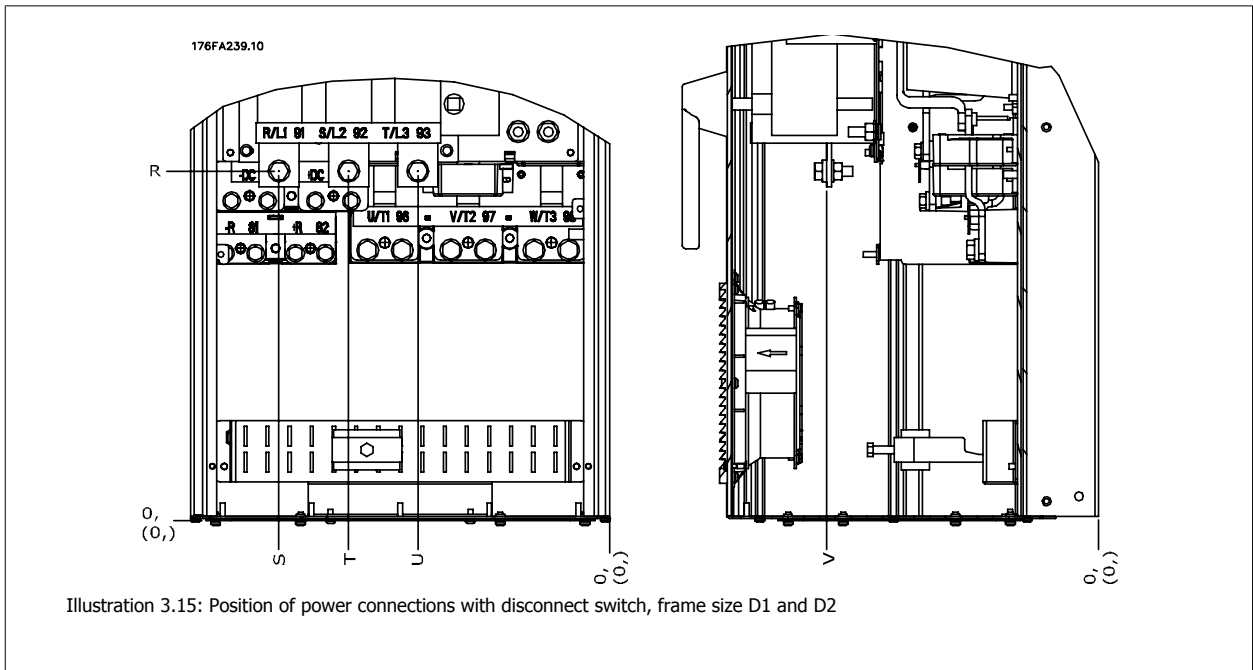

Illustration 3.15: Position of power connections with disconnect switch, frame size D1 and D2

Be aware that the power cables are heavy and hard to bend. Consider the optimum position of the frequency converter for ensuring easy installation of the cables.

**NB!**  
All D frames are available with standard input terminals or disconnect switch. All terminal dimensions can be found in the following table.

	IP 21 (NEMA 1) / IP 54 (NEMA 12)		IP 00 / Chassis	
	Frame size D1	Frame size D2	Frame size D3	Frame size D4
A	277 (10.9)	379 (14.9)	119 (4.7)	122 (4.8)
B	227 (8.9)	326 (12.8)	68 (2.7)	68 (2.7)
C	173 (6.8)	273 (10.8)	15 (0.6)	16 (0.6)
D	179 (7.0)	279 (11.0)	20.7 (0.8)	22 (0.8)
E	370 (14.6)	370 (14.6)	363 (14.3)	363 (14.3)
F	300 (11.8)	300 (11.8)	293 (11.5)	293 (11.5)
G	222 (8.7)	226 (8.9)	215 (8.4)	218 (8.6)
H	139 (5.4)	142 (5.6)	131 (5.2)	135 (5.3)
I	55 (2.2)	59 (2.3)	48 (1.9)	51 (2.0)
J	354 (13.9)	361 (14.2)	347 (13.6)	354 (13.9)
K	284 (11.2)	277 (10.9)	277 (10.9)	270 (10.6)
L	334 (13.1)	334 (13.1)	326 (12.8)	326 (12.8)
M	250 (9.8)	250 (9.8)	243 (9.6)	243 (9.6)
N	167 (6.6)	167 (6.6)	159 (6.3)	159 (6.3)
O	261 (10.3)	260 (10.3)	261 (10.3)	261 (10.3)
P	170 (6.7)	169 (6.7)	170 (6.7)	170 (6.7)
Q	120 (4.7)	120 (4.7)	120 (4.7)	120 (4.7)
R	256 (10.1)	350 (13.8)	98 (3.8)	93 (3.7)
S	308 (12.1)	332 (13.0)	301 (11.8)	324 (12.8)
T	252 (9.9)	262 (10.3)	245 (9.6)	255 (10.0)
U	196 (7.7)	192 (7.6)	189 (7.4)	185 (7.3)
V	260 (10.2)	273 (10.7)	260 (10.2)	273 (10.7)

Table 3.1: Cable positions as shown in drawings above. Dimensions in mm (inch).

### 3.3.4 Terminal Locations - Frame size E

#### Terminal Locations - E1

Take the following position of the terminals into consideration when designing the cable access.

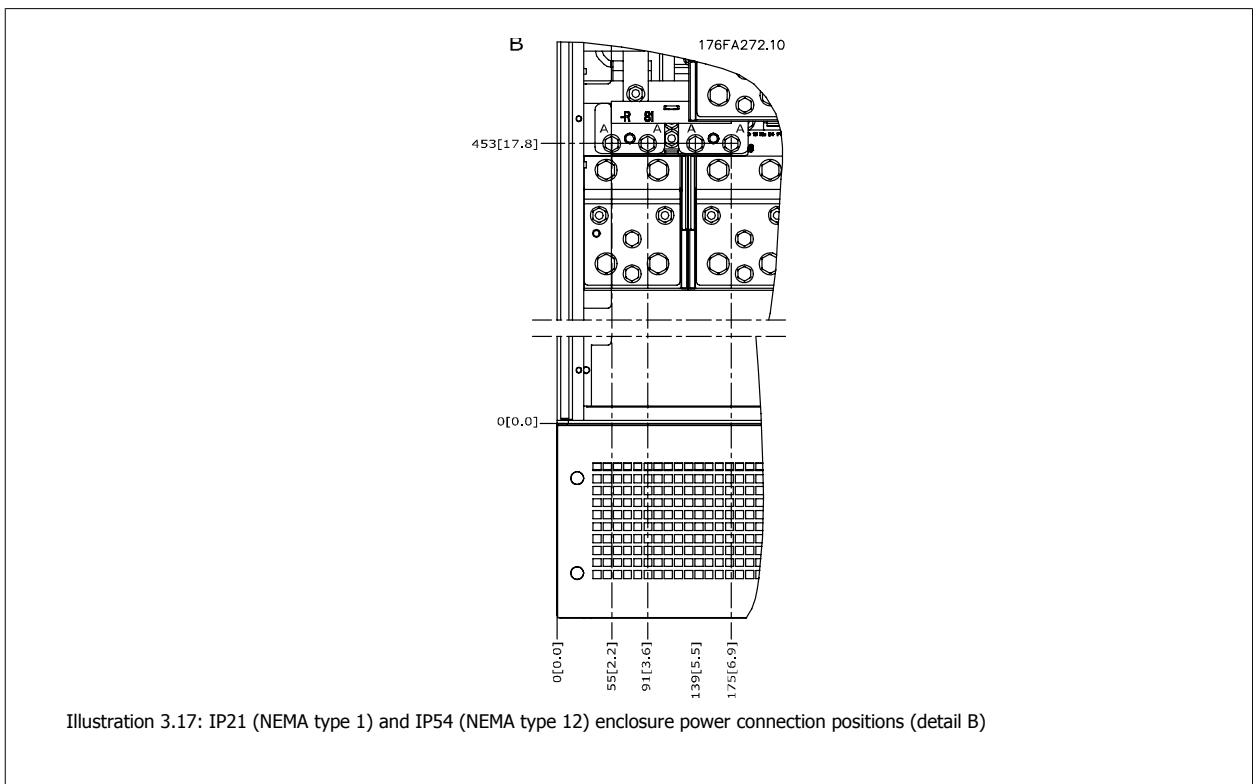
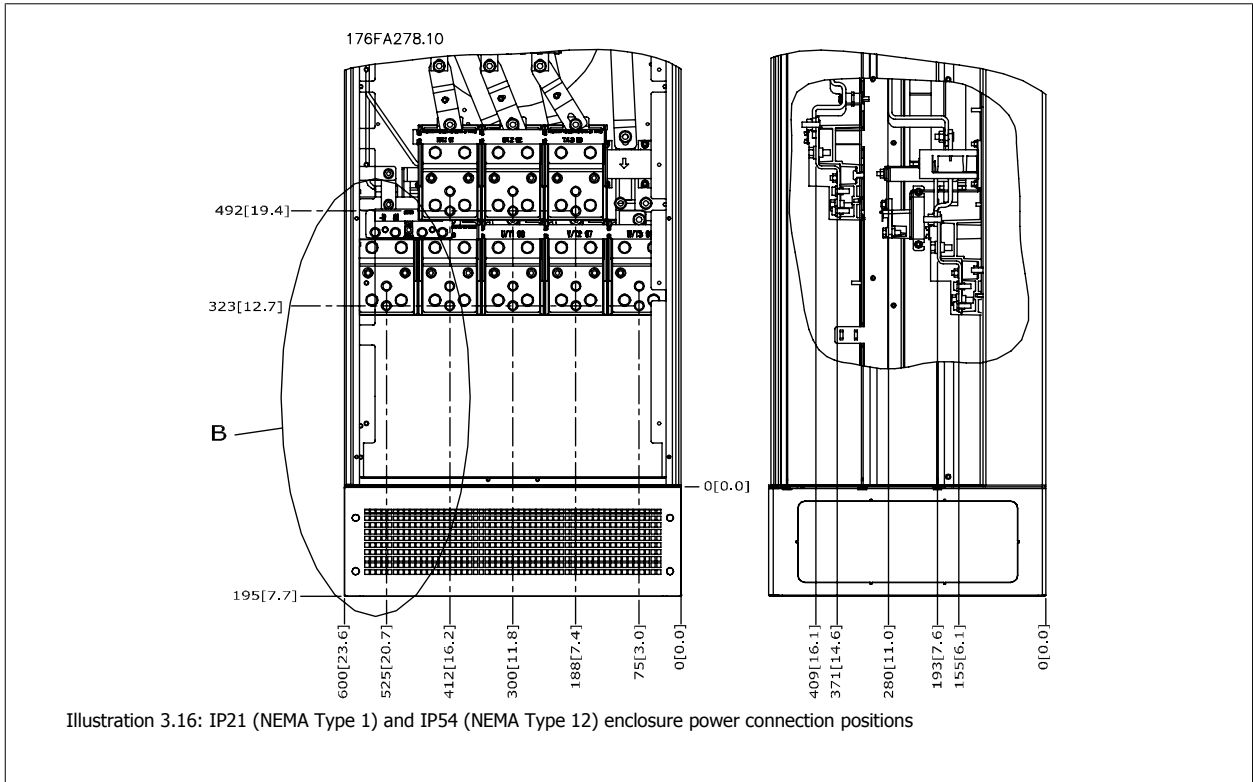

3

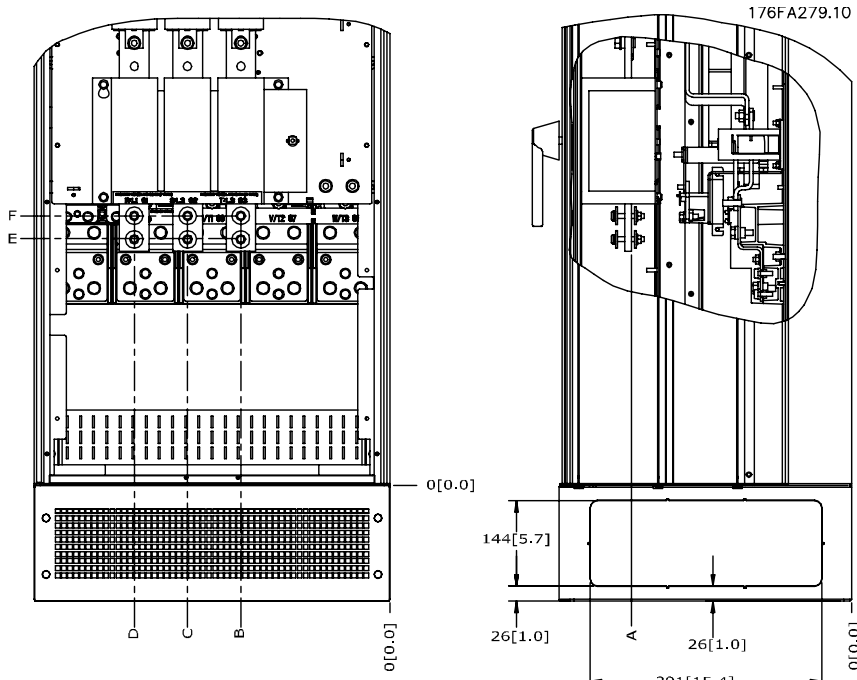

Illustration 3.18: IP21 (NEMA type 1) and IP54 (NEMA type 12) enclosure power connection position of disconnect switch

Frame size	Unit type	Dimension for disconnect terminal					
E1	IP54/IP21 UL AND NEMA1/NEMA12						
	250/315 kW (400V) AND 355/450-500/630 kW (690 V)	381 (15.0)	253 (9.9)	253 (9.9)	431 (17.0)	562 (22.1)	N/A
	315/355-400/450 kW (400V)	371 (14.6)	371 (14.6)	341 (13.4)	431 (17.0)	431 (17.0)	455 (17.9)



**Terminal locations - Frame size E2**

Take the following position of the terminals into consideration when designing the cable access.

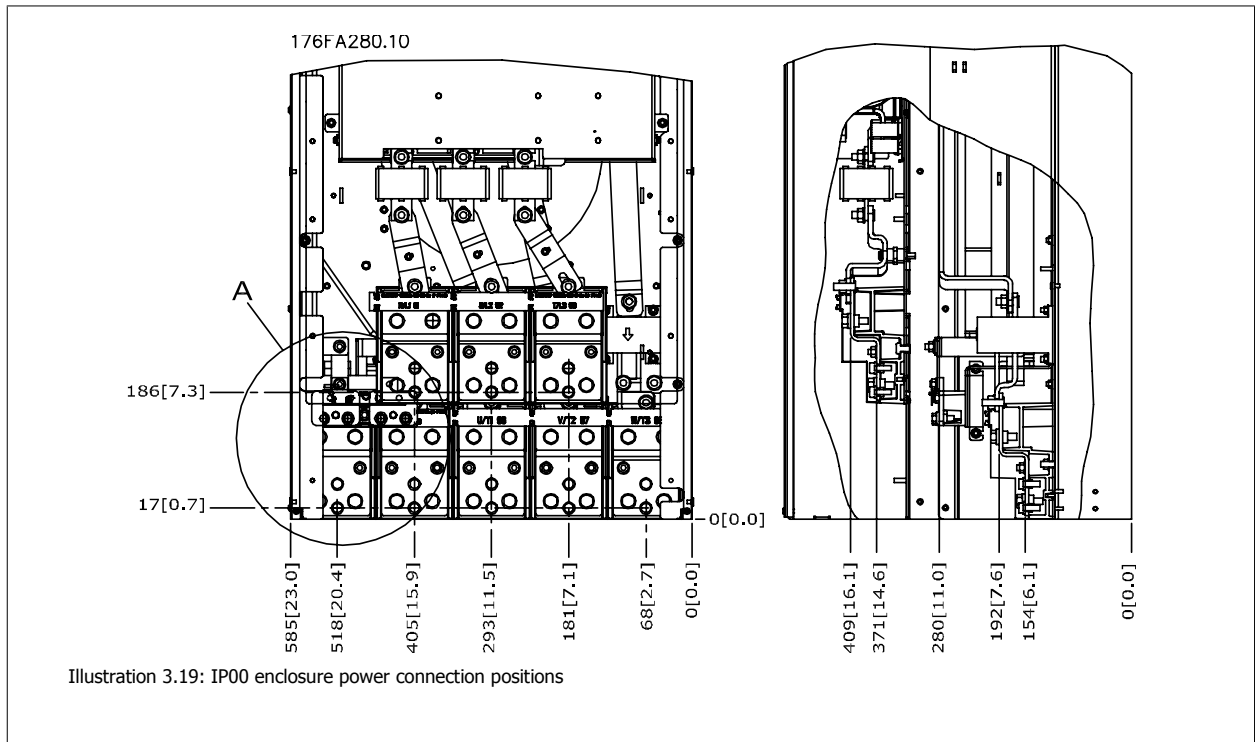

Illustration 3.19: IP00 enclosure power connection positions

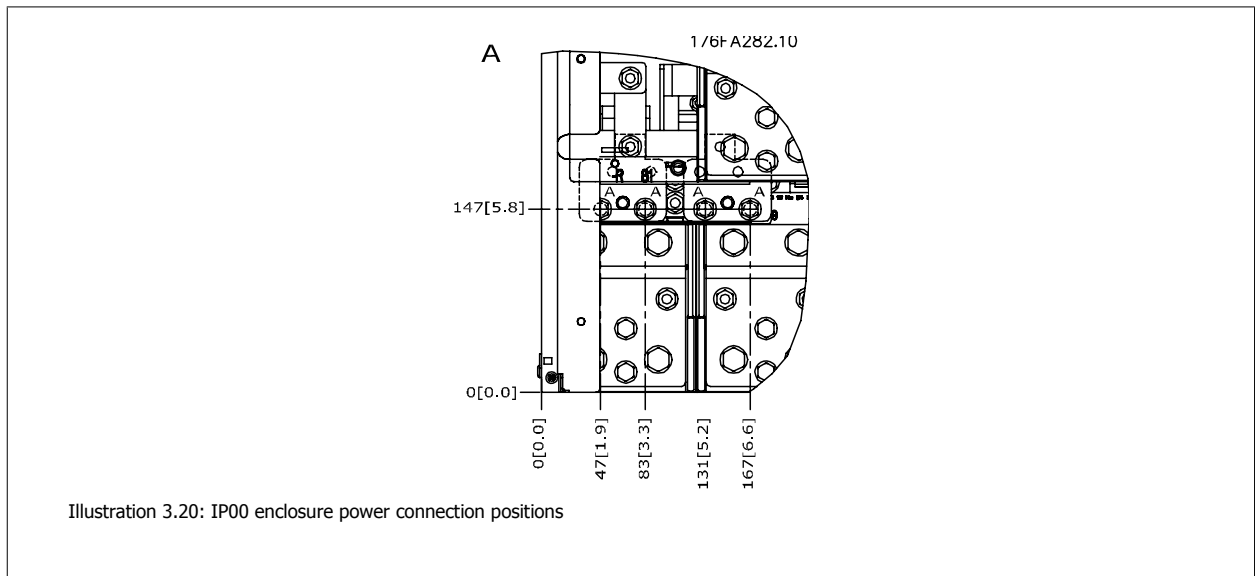

Illustration 3.20: IP00 enclosure power connection positions

3

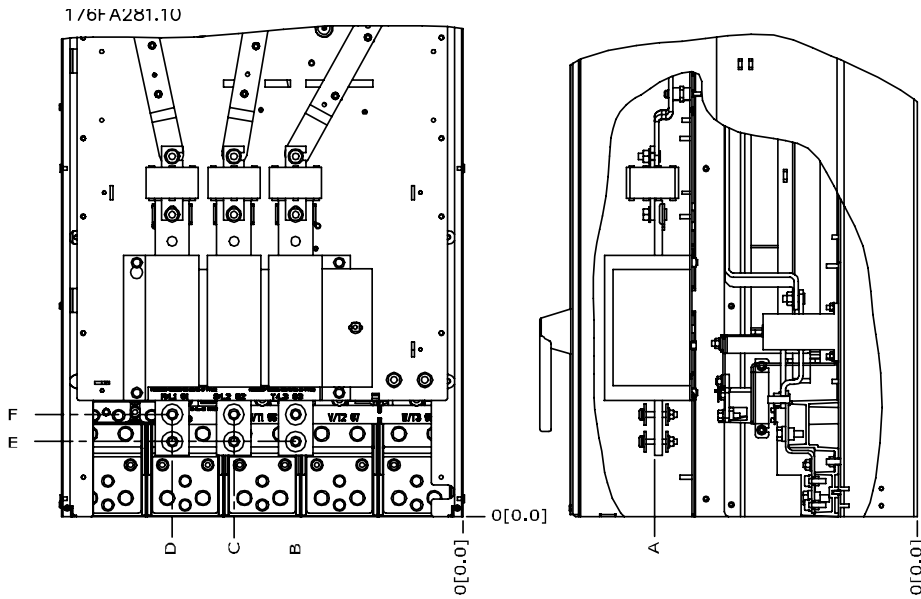

Illustration 3.21: IP00 enclosure power connections positions of disconnect switch

Note that the power cables are heavy and difficult to bend. Consider the optimum position of the frequency converter for ensuring easy installation of the cables.

Each terminal allows use of up to 4 cables with cable lugs or use of standard box lug. Earth is connected to relevant termination point in the drive.

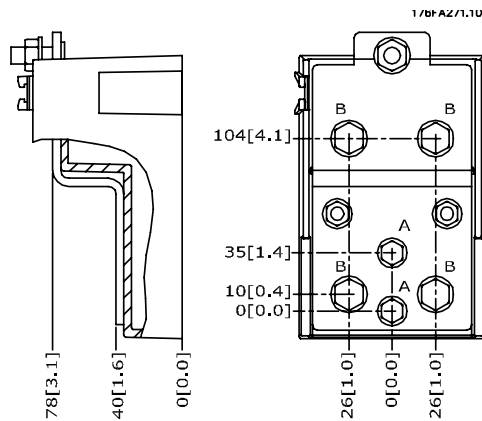

Illustration 3.22: Terminal in details



**NB!**  
Power connections can be made to positions A or B

Frame size	Unit type	Dimension for disconnect terminal					
		A	B	C	D	E	F
E2	IPOO/CHASSIS						
	250/315 kW (400V) AND 355/450-500/630 kW (690 V)	381 (15.0)	245 (9.6)	334 (13.1)	423 (16.7)	256 (10.1)	N/A
	315/355-400/450 kW (400V)	383 (15.1)	244 (9.6)	334 (13.1)	424 (16.7)	109 (4.3)	149 (5.8)

### 3.3.5 Terminal Locations - Frame size F

Terminal locations - Frame size F1 and F3

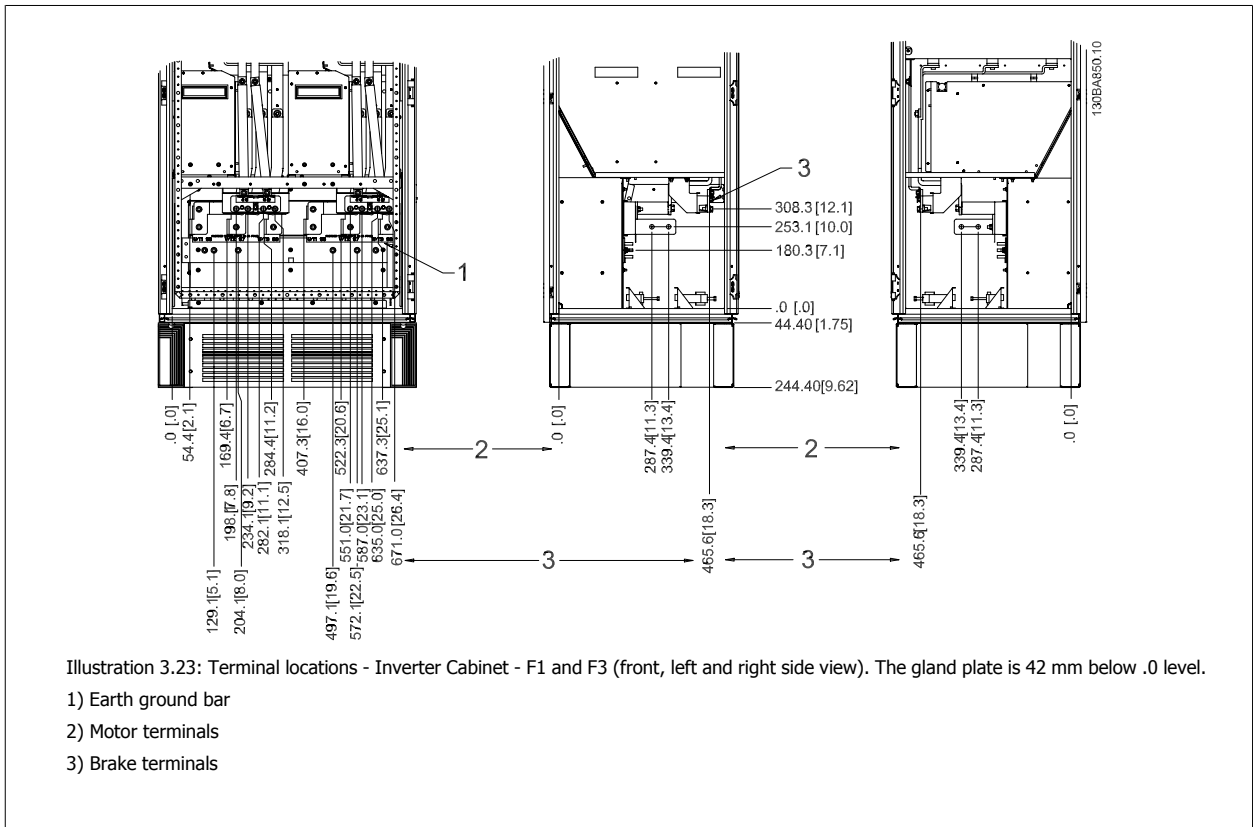

Terminal locations - Frame size F2 and F4

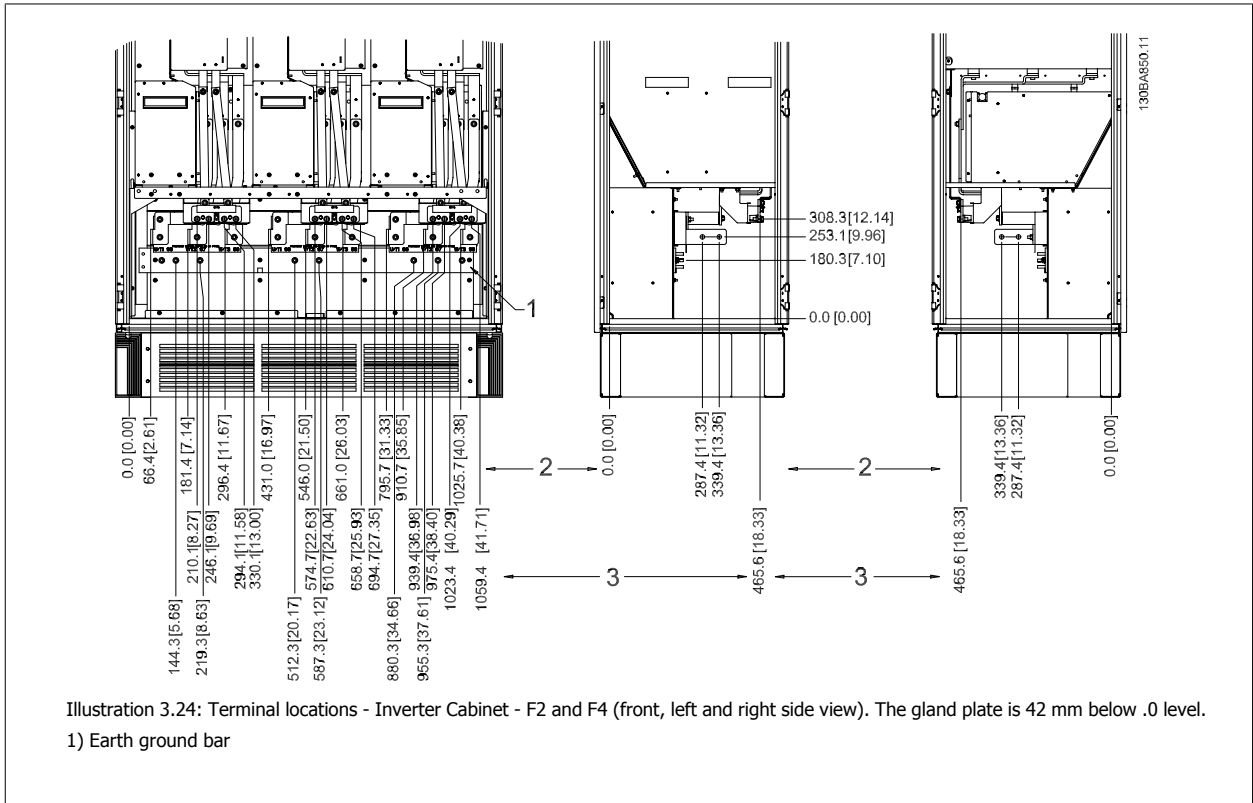

3

Terminal locations - Rectifier (F1, F2, F3 and F4)

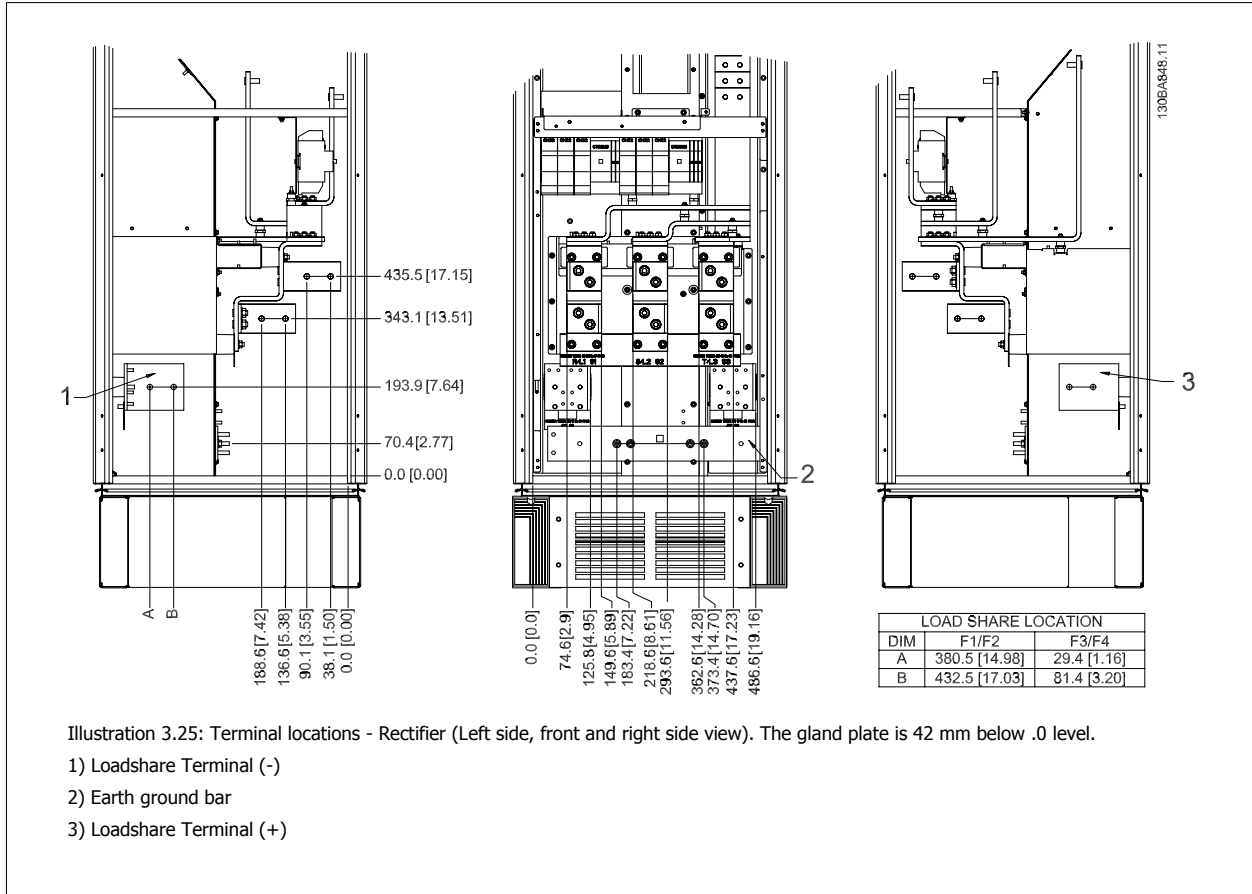

Terminal locations - Options Cabinet (F3 and F4)

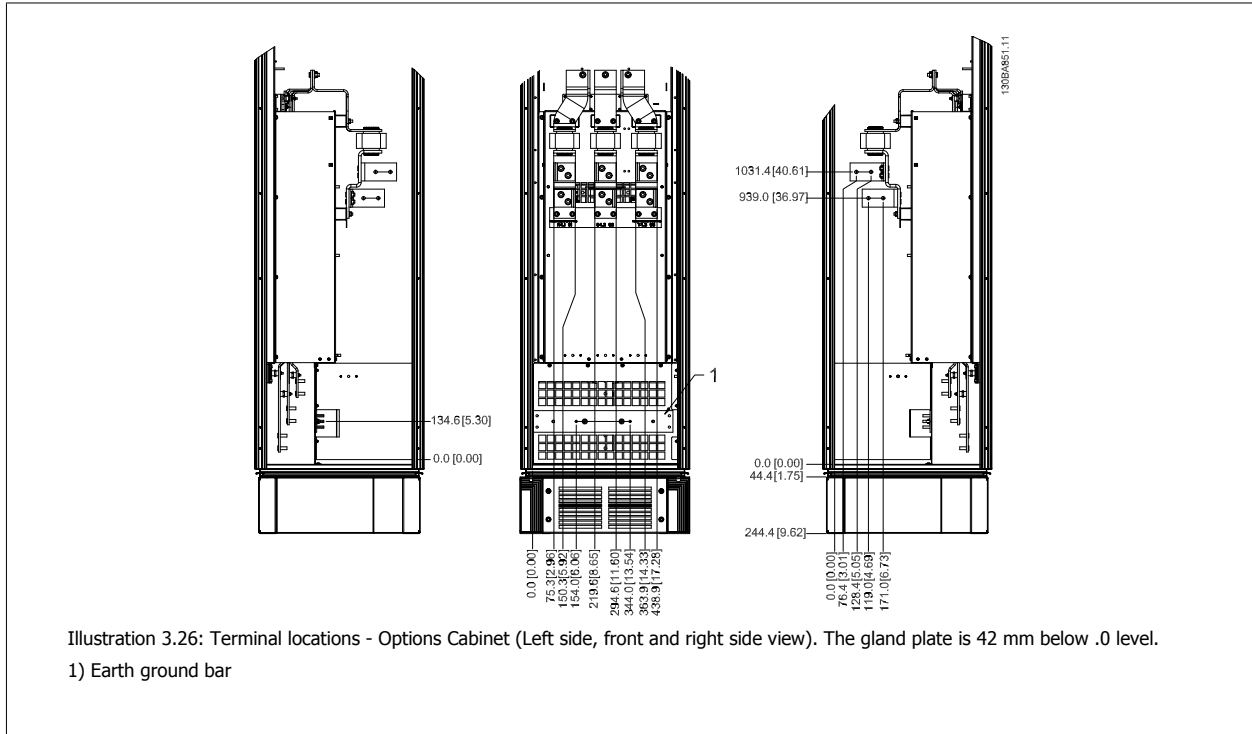

**Terminal locations - Options Cabinet with circuit breaker/ molded case switch (F3 and F4)**

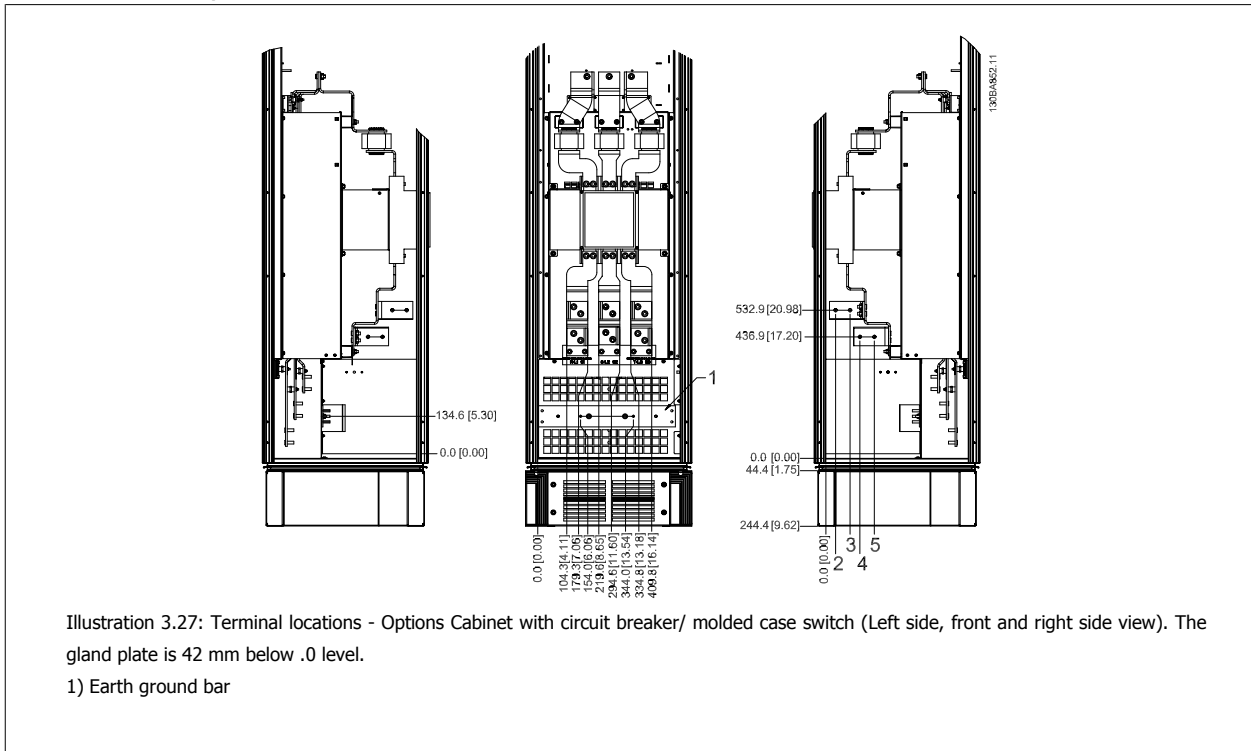

Power size	2	3	4	5
450 kW (480 V), 630-710 kW (690 V)	34.9	86.9	122.2	174.2
500-800 kW (480 V), 800-1000 kW (690 V)	46.3	98.3	119.0	171.0

Table 3.2: Dimension for terminal

**3.3.6 Cooling and Airflow**

**Cooling**

Cooling can be obtained in different ways, by using the cooling ducts in the bottom and the top of the unit, by taking air in and out the back of the unit or by combining the cooling possibilities.

**Duct cooling**

A dedicated option has been developed to optimize installation of IP00/chassis frequency converters in Rittal TS8 enclosures utilizing the fan of the frequency converter for forced air cooling of the backchannel. The air out the top of the enclosure could but ducted outside a facility so the heat losses from the backchannel are not dissipated within the control room reducing air-conditioning requirements of the facility.

Please see *Installation of Duct Cooling Kit in Rittal enclosures*, for further information.

**Back cooling**

The backchannel air can also be ventilated in and out the back of a Rittal TS8 enclosure. This offers a solution where the backchannel could take air from outside the facility and return the heat losses outside the facility thus reducing air-conditioning requirements.

**NB!**

A doorfan(s) is required on the enclosure to remove the heat losses not contained in the backchannel of the drive and any additional losses generated from other components installed inside the enclosure. The total required air flow must be calculated so that the appropriate fans can be selected. Some enclosure manufacturers offer software for performing the calculations (i.e. Rittal Therm software). If the drive is the only heat generating component in the enclosure, the minimum airflow required at an ambient temperature of 45°C for the D3 and D4 drives is 391 m<sup>3</sup>/h (230 cfm). The minimum airflow required at an ambient temperature of 45°C for the E2 drive is 782 m<sup>3</sup>/h (460 cfm).

**Airflow**

The necessary airflow over the heat sink must be secured. The flow rate is shown below.

**3**

Enclosure protection	Frame size	Door fan(s) / Top fan airflow	Heatsink fan(s)
IP21 / NEMA 1	D1 and D2	170 m <sup>3</sup> /h (100 cfm)	765 m <sup>3</sup> /h (450 cfm)
IP54 / NEMA 12	E1 P250T5, P355T7, P400T7	340 m <sup>3</sup> /h (200 cfm)	1105 m <sup>3</sup> /h (650 cfm)
	E1 P315-P400T5, P500-P560T7	340 m <sup>3</sup> /h (200 cfm)	1445 m <sup>3</sup> /h (850 cfm)
IP21 / NEMA 1	F1, F2, F3 and F4	700 m <sup>3</sup> /h (412 cfm)*	985 m <sup>3</sup> /h (580 cfm)*
IP54 / NEMA 12	F1, F2, F3 and F4	525 m <sup>3</sup> /h (309 cfm)*	985 m <sup>3</sup> /h (580 cfm)*
IP00 / Chassis	D3 and D4	255 m <sup>3</sup> /h (150 cfm)	765 m <sup>3</sup> /h (450 cfm)
	E2 P250T5, P355T7, P400T7	255 m <sup>3</sup> /h (150 cfm)	1105 m <sup>3</sup> /h (650 cfm)
	E2 P315-P400T5, P500-P560T7	255 m <sup>3</sup> /h (150 cfm)	1445 m <sup>3</sup> /h (850 cfm)
* Airflow per fan. Frame size F contain multiple fans.			

Table 3.3: Heatsink Air Flow

**External ducts**

If additional duct work is added externally to the Rittal cabinet the pressure drop in the ducting must be calculated. Use the charts below to derate the frequency converter according to the pressure drop.

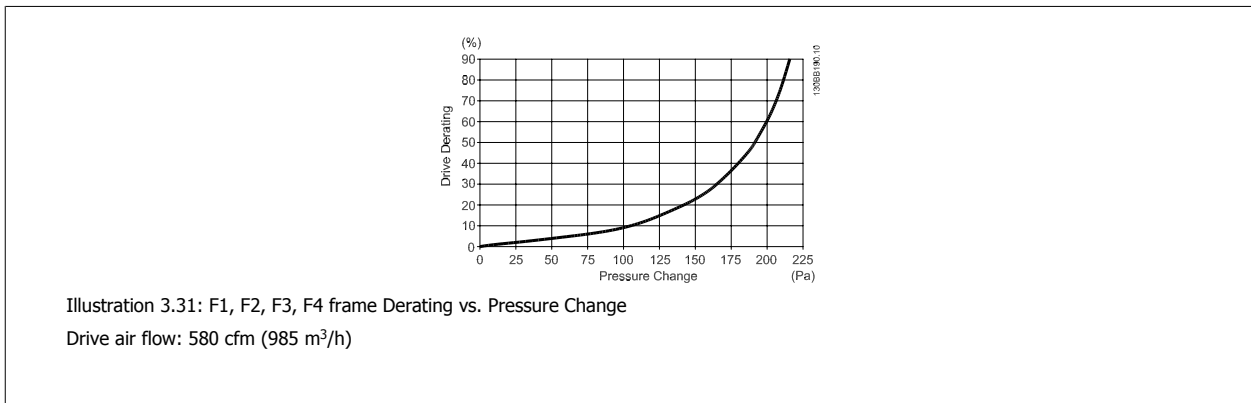
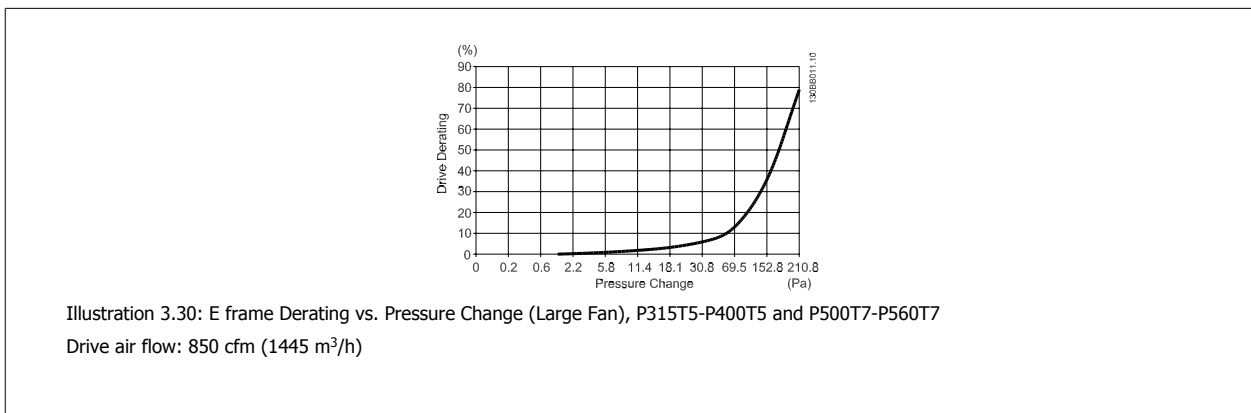
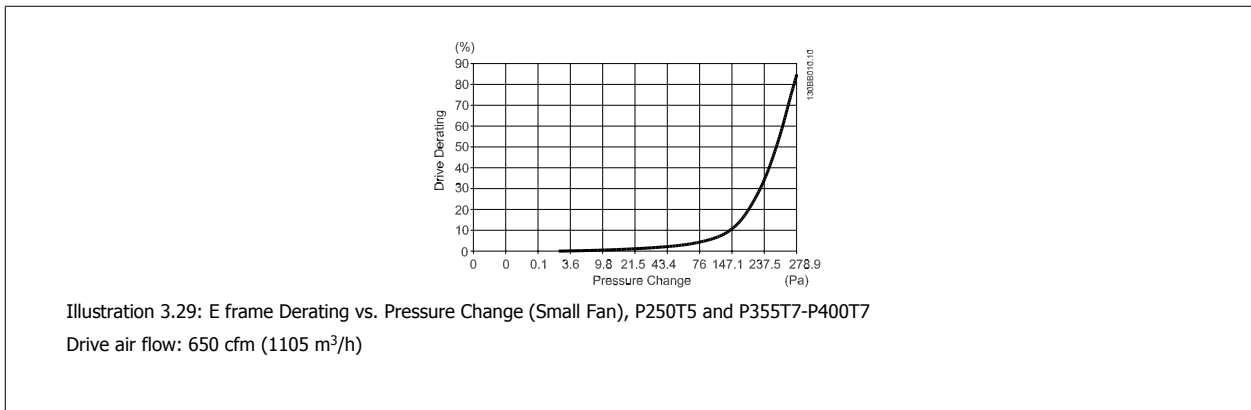
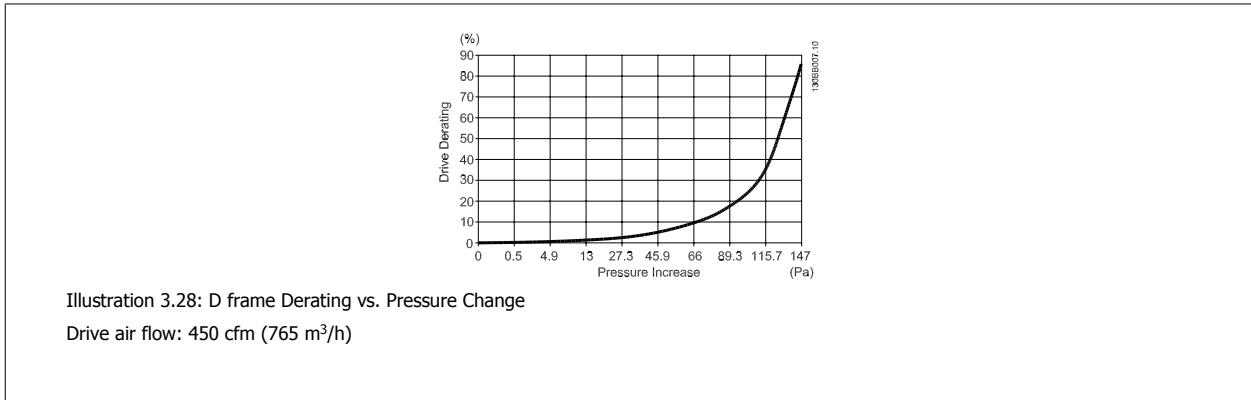

### 3.3.7 Installation on the Wall - IP21 (NEMA 1) and IP54 (NEMA 12) Units

This only applies to frame sizes D1 and D2 . It must be considered where to install the unit.

**Take the relevant points into consideration before you select the final installation site:**

- Free space for cooling
- Access to open the door
- Cable entry from the bottom

**3**

Mark the mounting holes carefully using the mounting template on the wall and drill the holes as indicated. Ensure proper distance to the floor and the ceiling for cooling. A minimum of 225 mm (8.9 inch) below the frequency converter is needed. Mount the bolts at the bottom and lift the frequency converter up on the bolts. Tilt the frequency converter against the wall and mount the upper bolts. Tighten all four bolts to secure the frequency converter against the wall.

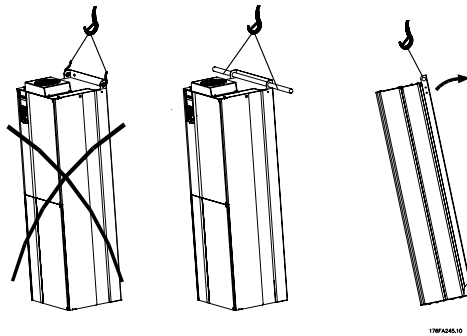

Illustration 3.32: Lifting method for mounting drive on wall



### 3.3.8 Gland/Conduit Entry - IP21 (NEMA 1) and IP54 (NEMA12)

Cables are connected through the gland plate from the bottom. Remove the plate and plan where to place the entry for the glands or conduits. Prepare holes in the marked area on the drawing.



**NB!**

The gland plate must be fitted to the frequency converter to ensure the specified protection degree, as well as ensuring proper cooling of the unit. If the gland plate is not mounted, the frequency converter may trip on Alarm 69, Pwr. Card Temp



130BB073.10

Illustration 3.33: Example of proper installation of the gland plate.

**Frame size D1 + D2**

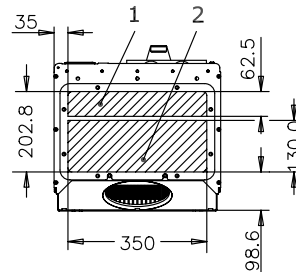

176FA289.11

**Frame size E1**

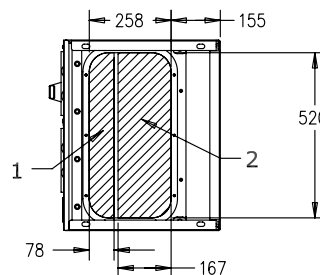

176FA290.11

Cable entries viewed from the bottom of the frequency converter - 1) Mains side 2) Motor side

3

Frame size F1

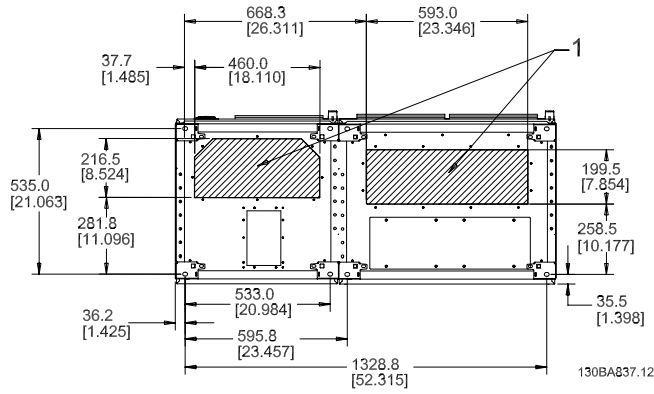

Frame size F2

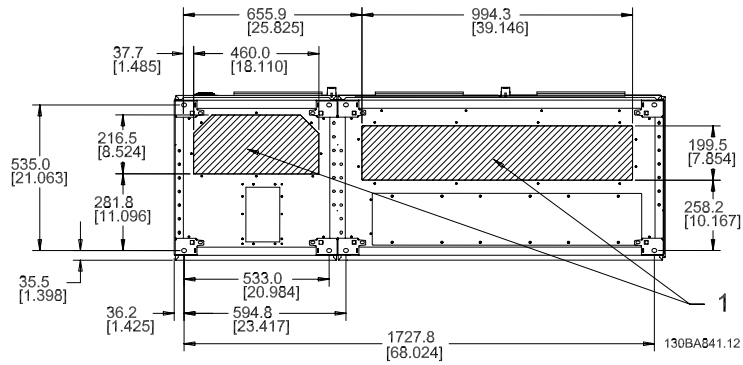

Frame size F3

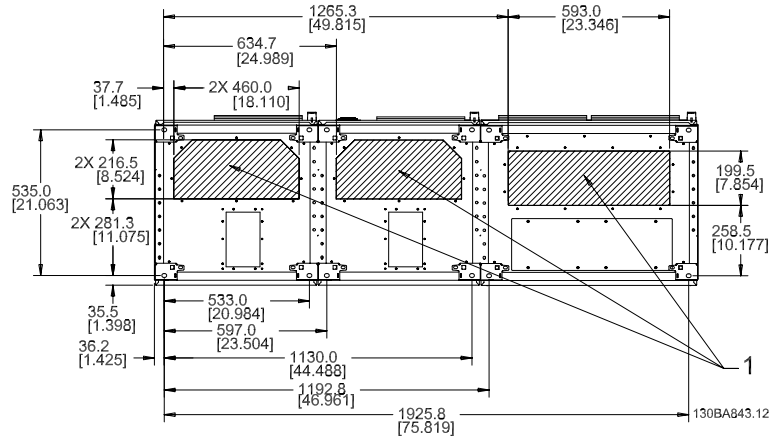

Frame size F4

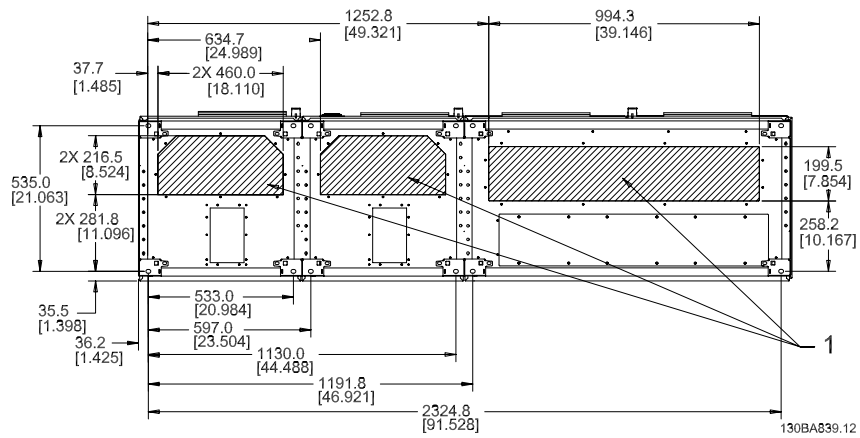

F1-F4: Cable entries viewed from the bottom of the frequency converter - 1) Place conduits in marked areas

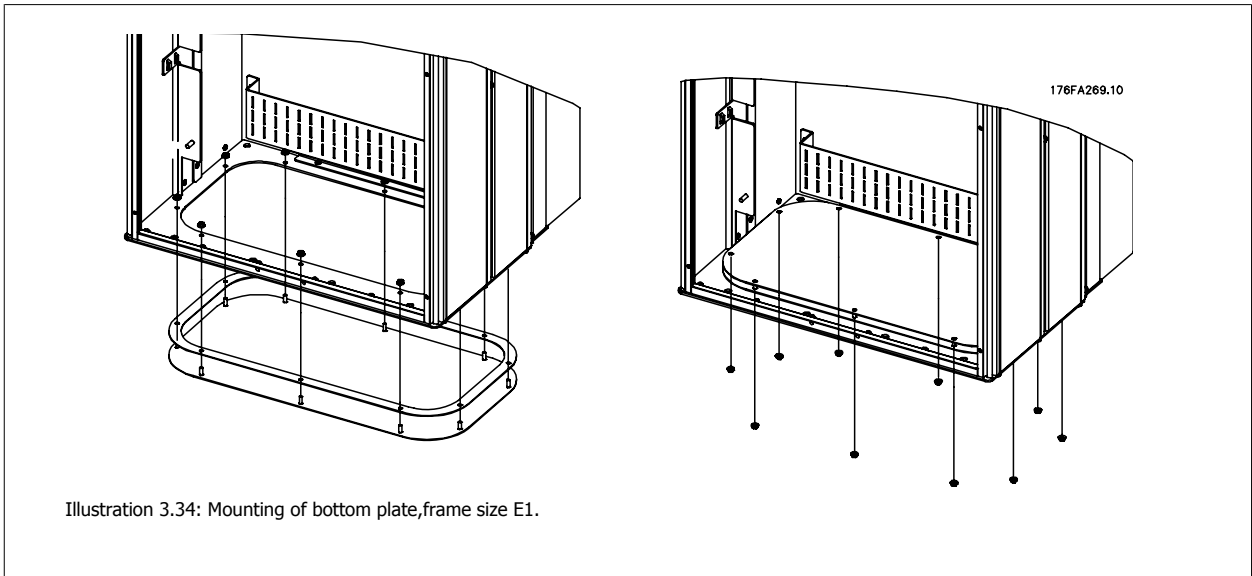

Illustration 3.34: Mounting of bottom plate, frame size E1.

The bottom plate of the E1 can be mounted from either in- or outside of the enclosure, allowing flexibility in the installation process, i.e. if mounted from the bottom the glands and cables can be mounted before the frequency converter is placed on the pedestal.

### 3.3.9 IP21 Drip Shield Installation (Frame size D1 and D2 )

To comply with the IP21 rating, a separate drip shield is to be installed as explained below:

- Remove the two front screws
- Insert the drip shield and replace screws
- Torque the screws to 5,6 Nm (50 in-lbs)

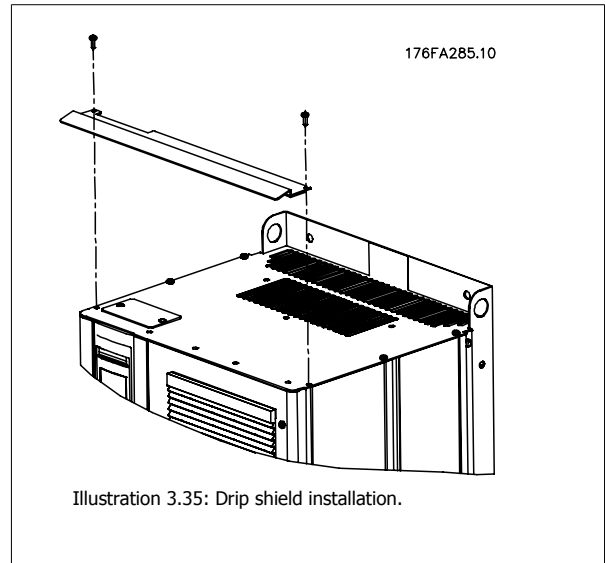

Illustration 3.35: Drip shield installation.

## 3.4 Field Installation of Options

### 3.4.1 Installation of Duct Cooling Kit in Rittal Enclosures

This section deals with the installation of IP00 / chassis enclosed frequency converters with duct work cooling kits in Rittal enclosures. In addition to the enclosure a 200 mm base/plinth is required.

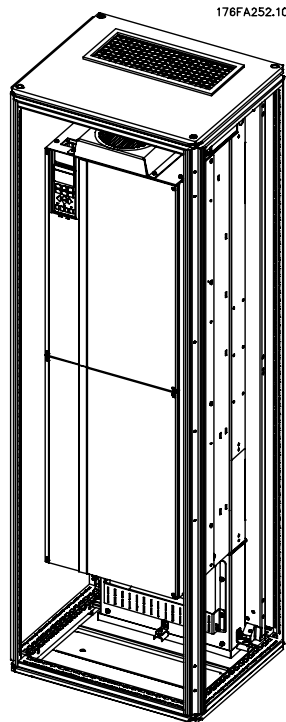

Illustration 3.36: Installation of IP00 in Rittal TS8 enclosure.

**The minimum enclosure dimension is:**

- D3 and D4 frame: Depth 500 mm and width 600 mm.
- E2 frame: Depth 600 mm and width 800 mm.

The maximum depth and width are as required by the installation. When using multiple frequency converters in one enclosure it is recommended that each drive is mounted on its own back panel and supported along the mid-section of the panel. These duct work kits do not support the "in frame" mounting of the panel (see Rittal TS8 catalogue for details). The duct work cooling kits listed in the table below are suitable for use only with IP 00 / Chassis frequency converters in Rittal TS8 IP 20 and UL and NEMA 1 and IP 54 and UL and NEMA 12 enclosures.



For the E2 frames it is important to mount the plate at the absolute rear of the Rittal enclosure due to the weight of the frequency converter.



**NB!**

A doorfan(s) is required on the enclosure to remove the heat losses not contained in the backchannel of the drive and any additional losses generated from other components installed inside the enclosure. The total required air flow must be calculated so that the appropriate fans can be selected. Some enclosure manufacturers offer software for performing the calculations (i.e. Rittal Therm software). If the drive is the only heat generating component in the enclosure, the minimum airflow required at an ambient temperature of 45°C for the D3 and D4 drives is 391 m<sup>3</sup>/h (230 cfm). The minimum airflow required at an ambient temperature of 45°C for the E2 drive is 782 m<sup>3</sup>/h (460 cfm).

**Ordering Information**

Rittal TS-8 Enclosure	Frame D3 Kit Part No.	Frame D4Kit Part No.	Frame E2 Part No.
1800 mm	176F1824	176F1823	Not possible
2000 mm	176F1826	176F1825	176F1850
2200 mm			176F0299

**NB!**  
Please see the *Duct Kit Instruction Manual, 175R5640*, for further information

**External ducts**

If additional duct work is added externally to the Rittal cabinet the pressure drop in the ducting must be calculated. Please see section *Cooling and Airflow* for further information.

**3.4.2 Outside Installation/ NEMA 3R Kit for Rittal Enclosures**



This section is for the installation of NEMA 3R kits available for the frequency converter frames D3, D4 and E2. These kits are designed and tested to be used with IP00/ Chassis versions of these frames in Rittal TS8 NEMA 3R or NEMA 4 enclosures. The NEMA-3R enclosure is an outdoor enclosure that provides a degree of protection against rain and ice. The NEMA-4 enclosure is an outdoor enclosure that provides a greater degree of protection against weather and hosed water.

The minimum enclosure depth is 500 mm (600 mm for E2 frame) and the kit is designed for a 600 mm (800 mm for E2 frame) wide enclosure. Other enclosure widths are possible, however additional Rittal hardware is required. The maximum depth and width are as required by the installation.

**NB!**  
The current rating of drives in D3 and D4 frames are de-rated by 3%, when adding the NEMA 3R kit. Drives in E2 frames require no derating

**NB!**  
A doorfan(s) is required on the enclosure to remove the heat losses not contained in the backchannel of the drive and any additional losses generated from other components installed inside the enclosure. The total required air flow must be calculated so that the appropriate fans can be selected. Some enclosure manufacturers offer software for performing the calculations (i.e. Rittal Therm software). If the drive is the only heat generating component in the enclosure, the minimum airflow required at an ambient temperature of 45°C for the D3 and D4 drives is 391 m<sup>3</sup>/h (230 cfm). The minimum airflow required at an ambient temperature of 45°C for the E2 drive is 782 m<sup>3</sup>/h (460 cfm).

**Ordering information**

Frame size D3: 176F4600  
 Frame size D4: 176F4601  
 Frame size E2: 176F1852



**NB!**  
 Please see the instructions *175R5922* for further information

**3**

**3.4.3 Installation on Pedestal**

This section describes the installation of a pedestal unit available for the frequency converters frames D1 and D2. This is a 200 mm high pedestal that allows these frames to be floor mounted. The front of the pedestal has openings for input air to the power components.

The frequency converter gland plate must be installed to provide adequate cooling air to the control components of the frequency converter via the door fan and to maintain the IP21/NEMA 1 or IP54/NEMA 12 degrees of enclosure protections.



Illustration 3.37: Drive on pedestal

There is one pedestal that fits both frames D1 and D2. Its ordering number is 176F1827. The pedestal is standard for E1 frame.

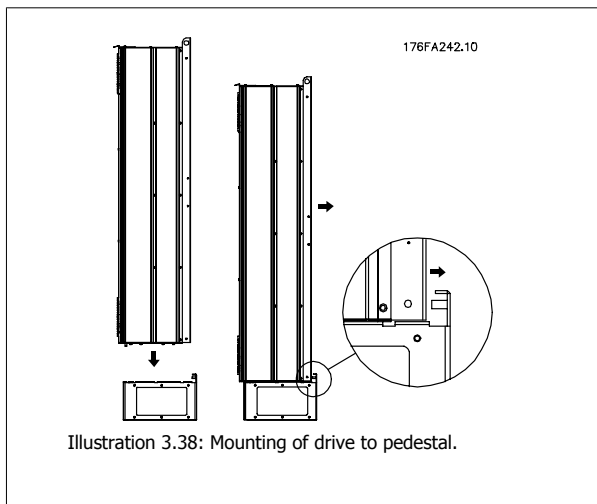



Illustration 3.38: Mounting of drive to pedestal.



**NB!**  
 Please see the *Pedestal Kit Instruction Manual, 175R5642*, for further information.

### 3.4.4 Installation of Input Plate Options

This section is for the field installation of input option kits available for frequency converters in all D and E frames. Do not attempt to remove RFI filters from input plates. Damage may occur to RFI filters if they are removed from the input plate.



**NB!**  
Where RFI filters are available, there are two different type of RFI filters depending on the input plate combination and the RFI filters interchangeable. Field installable kits in certain cases are the same for all voltages.

	380 - 480 V 380 - 500 V	Fuses	Disconnect Fuses	RFI	RFI Fuses	RFI Disconnect Fuses
D1	All D1 power sizes	176F8442	176F8450	176F8444	176F8448	176F8446
D2	All D2 power sizes	176F8443	176F8441	176F8445	176F8449	176F8447
E1	IVS 102/ : 315 kW	176F0253	176F0255	176F0257	176F0258	176F0260
	IVS 102: 250 kW					
	IVS 102/ : 355 - 450 kW	176F0254	176F0256	176F0257	176F0259	176F0262
	IVS 102: 315 - 400 kW					

	525 - 690 V	Fuses	Disconnect Fuses	RFI	RFI Fuses	RFI Disconnect Fuses
D1	IVS 102/ : 45-90 kW	175L8829	175L8828	175L8777	NA	NA
	IVS 102: 37-75 kW					
	IVS 102/ : 110-160 kW	175L8442	175L8445	175L8777	NA	NA
	IVS 102: 90-132 kW					
D2	All D2power sizes	175L8827	175L8826	175L8825	NA	NA
E1	IVS 102/ : 450-500 kW	176F0253	176F0255	NA	NA	NA
	IVS 102: 355-400 kW					
	IVS 102/ : 560-630 kW	176F0254	176F0258	NA	NA	NA
	IVS 102: 500-560 kW					



**NB!**  
For further information, please see the Instruction Sheet, *175R5795*

### 3.4.5 Installation of Mains Shield for Frequency Converters

This section is for the installation of a mains shield for the frequency converter series with D1, D2 and E1 frames. It is not possible to install in the IP00/ Chassis versions as these have included as standard a metal cover. These shields satisfy VBG-4 requirements.

**Ordering numbers:**

Frames D1 and D2 : 176F0799

Frame E1: 176F1851



**NB!**  
For further information, please see the Instruction Sheet, *175R5923*

## 3.5 Frame size F Panel Options

### 3.5.1 Frame Size F Panel Options

#### Space Heaters and Thermostat

Mounted on the cabinet interior of frame size F frequency converters, space heaters controlled via automatic thermostat help control humidity inside the enclosure, extending the lifetime of drive components in damp environments. The thermostat default settings turn on the heaters at 10° C (50° F) and turn them off at 15.6° C (60° F).

#### Cabinet Light with Power Outlet

A light mounted on the cabinet interior of frame size F frequency converters increase visibility during servicing and maintenance. The housing the light includes a power outlet for temporarily powering tools or other devices, available in two voltages:

- 230V, 50Hz, 2.5A, CE/ENEC
- 120V, 60Hz, 5A, UL/cUL

#### Transformer Tap Setup

If the Cabinet Light & Outlet and/or the Space Heaters & Thermostat are installed Transformer T1 requires it taps to be set to the proper input voltage. A 380-480/ 500 V380-480 V drive will initially be set to the 525 V tap and a 525-690 V drive will be set to the 690 V tap to insure no over-voltage of secondary equipment occurs if the tap is not changed prior to power being applied. See the table below to set the proper tap at terminal T1 located in the rectifier cabinet. For location in the drive, see illustration of rectifier in the *Power Connections* section.

Input Voltage Range	Tap to Select
380V-440V	400V
441V-490V	460V
491V-550V	525V
551V-625V	575V
626V-660V	660V
661V-690V	690V

#### NAMUR Terminals

NAMUR is an international association of automation technology users in the process industries, primarily chemical and pharmaceutical industries in Germany. Selection of this option provides terminals organized and labeled to the specifications of the NAMUR standard for drive input and output terminals. This requires MCB 112 PTC Thermistor Card and MCB 113 Extended Relay Card.

#### RCD (Residual Current Device)

Uses the core balance method to monitor ground fault currents in grounded and high-resistance grounded systems (TN and TT systems in IEC terminology). There is a pre-warning (50% of main alarm set-point) and a main alarm set-point. Associated with each set-point is an SPDT alarm relay for external use. Requires an external "window-type" current transformer (supplied and installed by customer).

- Integrated into the drive's safe-stop circuit
- IEC 60755 Type B device monitors AC, pulsed DC, and pure DC ground fault currents
- LED bar graph indicator of the ground fault current level from 10–100% of the set-point
- Fault memory
- TEST / RESET button

#### Insulation Resistance Monitor (IRM)

Monitors the insulation resistance in ungrounded systems (IT systems in IEC terminology) between the system phase conductors and ground. There is an ohmic pre-warning and a main alarm set-point for the insulation level. Associated with each set-point is an SPDT alarm relay for external use. Note: only one insulation resistance monitor can be connected to each ungrounded (IT) system.

- Integrated into the drive's safe-stop circuit
- LCD display of the ohmic value of the insulation resistance
- Fault Memory
- INFO, TEST, and RESET buttons

#### IEC Emergency Stop with Pilz Safety Relay

Includes a redundant 4-wire emergency-stop push-button mounted on the front of the enclosure and a Pilz relay that monitors it in conjunction with the drive's safe-stop circuit and the mains contactor located in the options cabinet.



**Manual Motor Starters**

Provide 3-phase power for electric blowers often required for larger motors. Power for the starters is provided from the load side of any supplied contactor, circuit breaker, or disconnect switch. Power is fused before each motor starter, and is off when the incoming power to the drive is off. Up to two starters are allowed (one if a 30A, fuse-protected circuit is ordered). Integrated into the drive's safe-stop circuit.

Unit features include:

- Operation switch (on/off)
- Short-circuit and overload protection with test function
- Manual reset function

**30 Ampere, Fuse-Protected Terminals**

- 3-phase power matching incoming mains voltage for powering auxiliary customer equipment
- Not available if two manual motor starters are selected
- Terminals are off when the incoming power to the drive is off
- Power for the fused protected terminals will be provided from the load side of any supplied contactor, circuit breaker, or disconnect switch.

**24 VDC Power Supply**

- 5 amp, 120 W, 24 VDC
- Protected against output over-current, overload, short circuits, and over-temperature
- For powering customer-supplied accessory devices such as sensors, PLC I/O, contactors, temperature probes, indicator lights, and/or other electronic hardware
- Diagnostics include a dry DC-ok contact, a green DC-ok LED, and a red overload LED

**External Temperature Monitoring**

Designed for monitoring temperatures of external system components, such as the motor windings and/or bearings. Includes eight universal input modules plus two dedicated thermistor input modules. All ten modules are integrated into the drive's safe-stop circuit and can be monitored via a fieldbus network (requires the purchase of a separate module/bus coupler).

**Universal inputs (8)**

Signal types:

- RTD inputs (including Pt100), 3-wire or 4-wire
- Thermocouple
- Analog current or analog voltage

Additional features:

- One universal output, configurable for analog voltage or analog current
- Two output relays (N.O.)
- Dual-line LC display and LED diagnostics
- Sensor lead wire break, short-circuit, and incorrect polarity detection
- Interface setup software

**Dedicated thermistor inputs (2)**

Features:

- Each module capable of monitoring up to six thermistors in series
- Fault diagnostics for wire breakage or short-circuits of sensor leads
- ATEX/UL/CSA certification
- A third thermistor input can be provided by the PTC Thermistor Option Card MCB 112, if necessary

**4**

## 4 Electrical Installation

### 4.1 Electrical Installation

#### 4.1.1 Power Connections

##### Cabling and Fusing

**NB!**  
**Cables General**  
 All cabling must comply with national and local regulations on cable cross-sections and ambient temperature. UL applications require 75 °C copper conductors. 75 and 90 °C copper conductors are thermally acceptable for the frequency converter to use in non UL applications.

The power cable connections are situated as shown below. Dimensioning of cable cross section must be done in accordance with the current ratings and local legislation. See the *Specifications section* for details.

For protection of the frequency converter, the recommended fuses must be used or the unit must be with built-in fuses. Recommended fuses can be seen in the tables of the fuse section. Always ensure that proper fusing is made according to local regulation.

The mains connection is fitted to the mains switch if this is included.

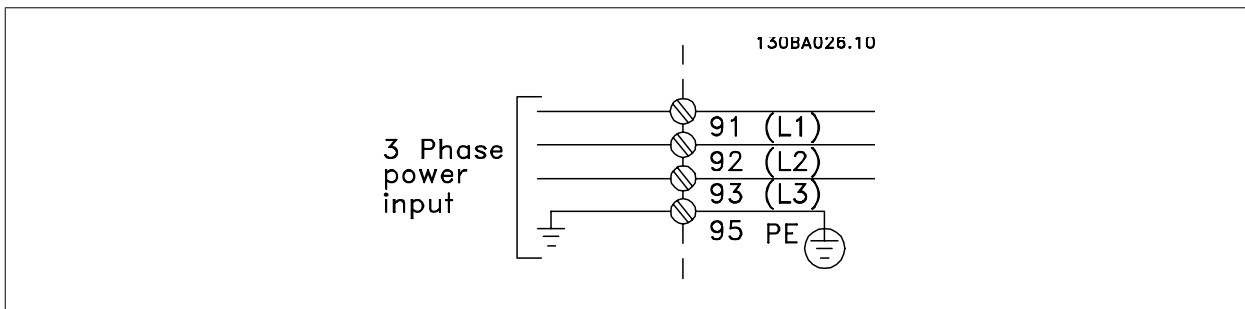

**NB!**  
 The motor cable must be screened/armoured. If an unscreened/unarmoured cable is used, some EMC requirements are not complied with. Use a screened/armoured motor cable to comply with EMC emission specifications. For more information, see *EMC specifications* in the *Design Guide*.

See section *General Specifications* for correct dimensioning of motor cable cross-section and length.

##### Screening of cables:

Avoid installation with twisted screen ends (pigtailed). They spoil the screening effect at higher frequencies. If it is necessary to break the screen to install a motor isolator or motor contactor, the screen must be continued at the lowest possible HF impedance.

Connect the motor cable screen to both the de-coupling plate of the frequency converter and to the metal housing of the motor.

Make the screen connections with the largest possible surface area (cable clamp). This is done by using the supplied installation devices within the frequency converter.

##### Cable-length and cross-section:

The frequency converter has been EMC tested with a given length of cable. Keep the motor cable as short as possible to reduce the noise level and leakage currents.

##### Switching frequency:

When frequency converters are used together with Sine-wave filters to reduce the acoustic noise from a motor, the switching frequency must be set according to the instruction in par. 14-01 *Switching Frequency*.

Term. no.	96	97	98	99	
	U	V	W	PE <sup>1)</sup>	Motor voltage 0-100% of mains voltage.
	U1	V1	W1		3 wires out of motor
	W2	U2	V2	PE <sup>1)</sup>	Delta-connected
	U1	V1	W1	PE <sup>1)</sup>	6 wires out of motor
					Star-connected U2, V2, W2
					U2, V2 and W2 to be interconnected separately.

<sup>1)</sup>Protected Earth Connection

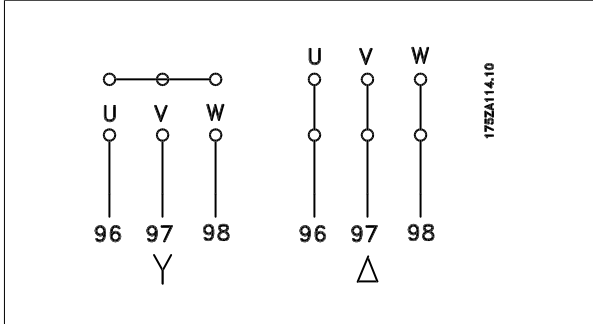

**NB!**

In motors without phase insulation paper or other insulation reinforcement suitable for operation with voltage supply (such as a frequency converter), fit a Sine-wave filter on the output of the frequency converter.

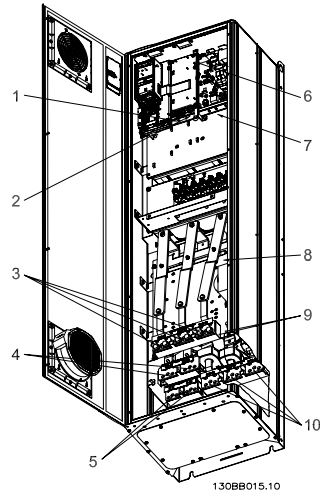

Illustration 4.1: Compact IP 21 (NEMA 1) and IP 54 (NEMA 12), frame size D1

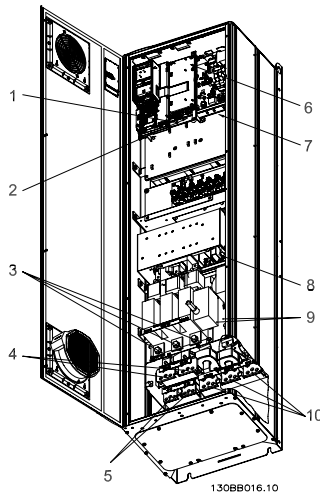

Illustration 4.2: Compact IP 21 (NEMA 1) and IP 54 (NEMA 12) with disconnect, fuse and RFI filter, frame size D2

1) AUX Relay	5) Brake
01 02 03	-R +R
04 05 06	81 82
2) Temp Switch	6) SMPS Fuse (see fuse tables for part number)
106 104 105	7) AUX Fan
3) Line	100 101 102 103
R S T	L1 L2 L1 L2
91 92 93	8) Fan Fuse (see fuse tables for part number)
L1 L2 L3	9) Mains ground
4) Load sharing	10) Motor
-DC +DC	U V W
88 89	96 97 98
	T1 T2 T3

4

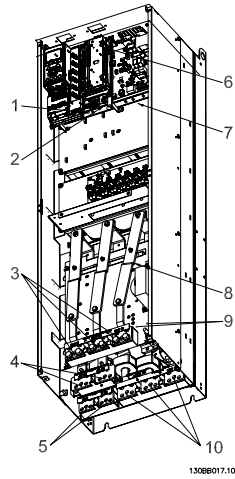

Illustration 4.3: Compact IP 00 (Chassis), frame size D3

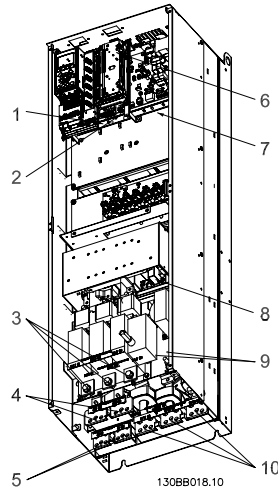
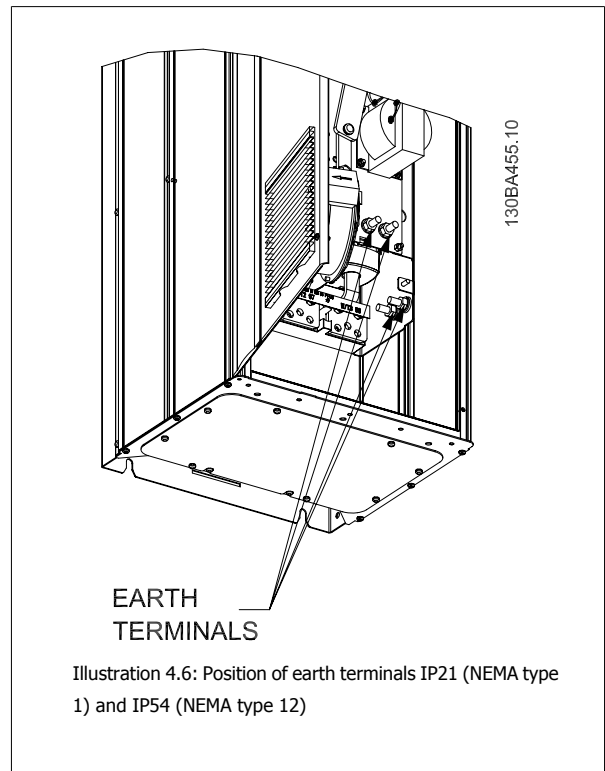
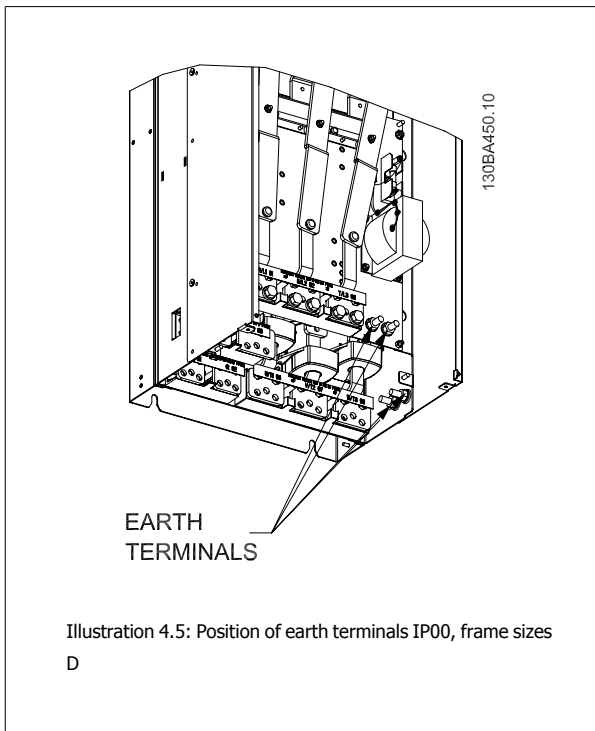

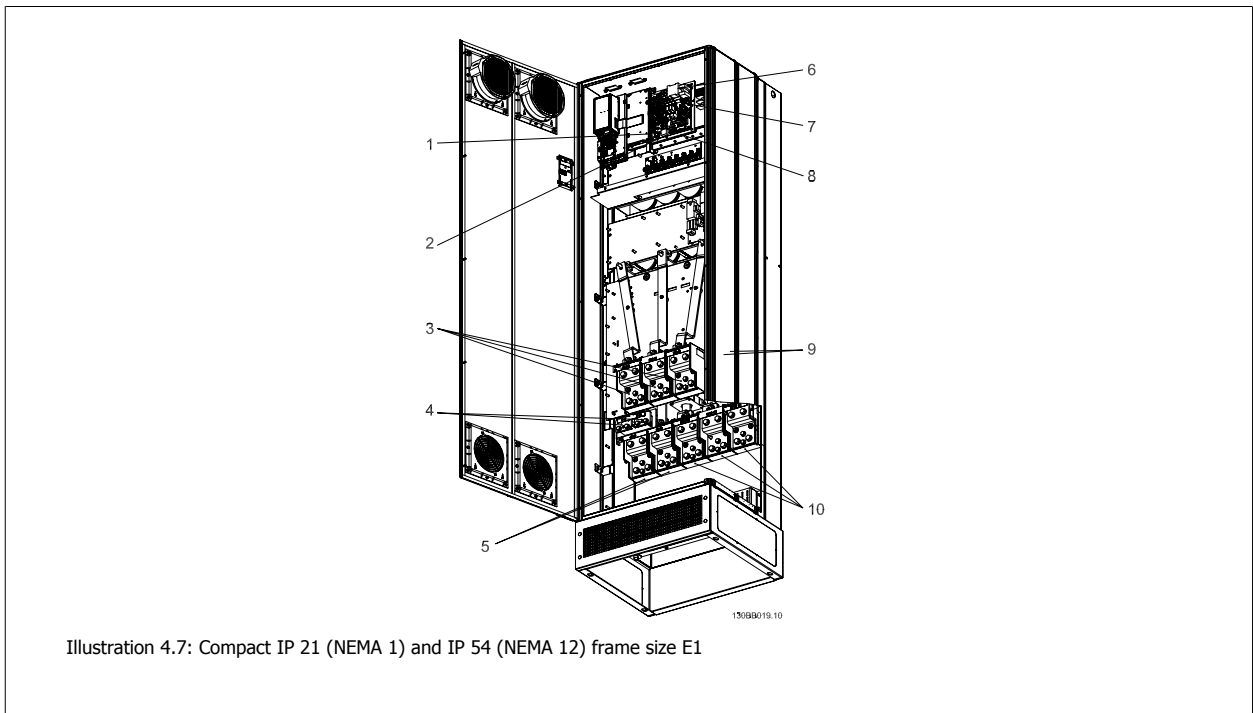

Illustration 4.4: Compact IP 00 (Chassis) with disconnect, fuse and RFI filter, frame size D4

- |   |   |
|---|---|
| <p>1) AUX Relay<br/>01 02 03<br/>04 05 06</p> <p>2) Temp Switch<br/>106 104 105</p> <p>3) Line<br/>R S T<br/>91 92 93<br/>L1 L2 L3</p> <p>4) Load sharing<br/>-DC +DC<br/>88 89</p> | <p>5) Brake<br/>-R +R<br/>81 82</p> <p>6) SMPS Fuse (see fuse tables for part number)</p> <p>7) AUX Fan<br/>100 101 102 103<br/>L1 L2 L1 L2</p> <p>8) Fan Fuse (see fuse tables for part number)</p> <p>9) Mains ground</p> <p>10) Motor<br/>U V W<br/>96 97 98<br/><br/>T1 T2 T3</p> |
|---|---|



 **NB!**  
D2 and D4 shown as examples. D1 and D3 are equivalent.



4

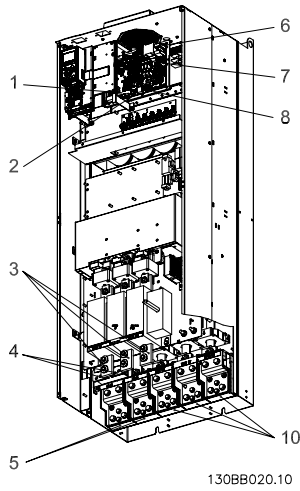

Illustration 4.8: Compact IP 00 (Chassis) with disconnect, fuse and RFI filter, frame size E2

- |  |   |
|--|---|
| <p>1) AUX Relay<br/>01 02 03<br/>04 05 06</p> <p>2) Temp Switch<br/>106 104 105</p> <p>3) Line<br/>R S T<br/>91 92 93<br/>L1 L2 L3</p> <p>4) Brake<br/>-R +R<br/>81 82</p> | <p>5) Load sharing<br/>-DC +DC<br/>88 89</p> <p>6) SMPS Fuse (see fuse tables for part number)</p> <p>7) Fan Fuse (see fuse tables for part number)</p> <p>8) AUX Fan<br/>100 101 102 103<br/>L1 L2 L1 L2</p> <p>9) Mains ground</p> <p>10) Motor<br/>U V W<br/>96 97 98<br/>T1 T2 T3</p> |
|--|---|

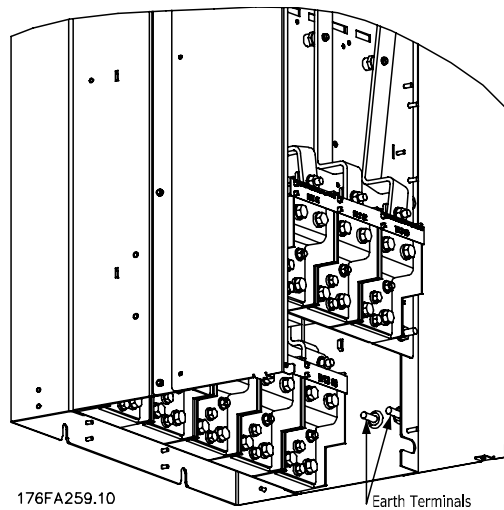

Illustration 4.9: Position of earth terminals IP00, frame sizes E



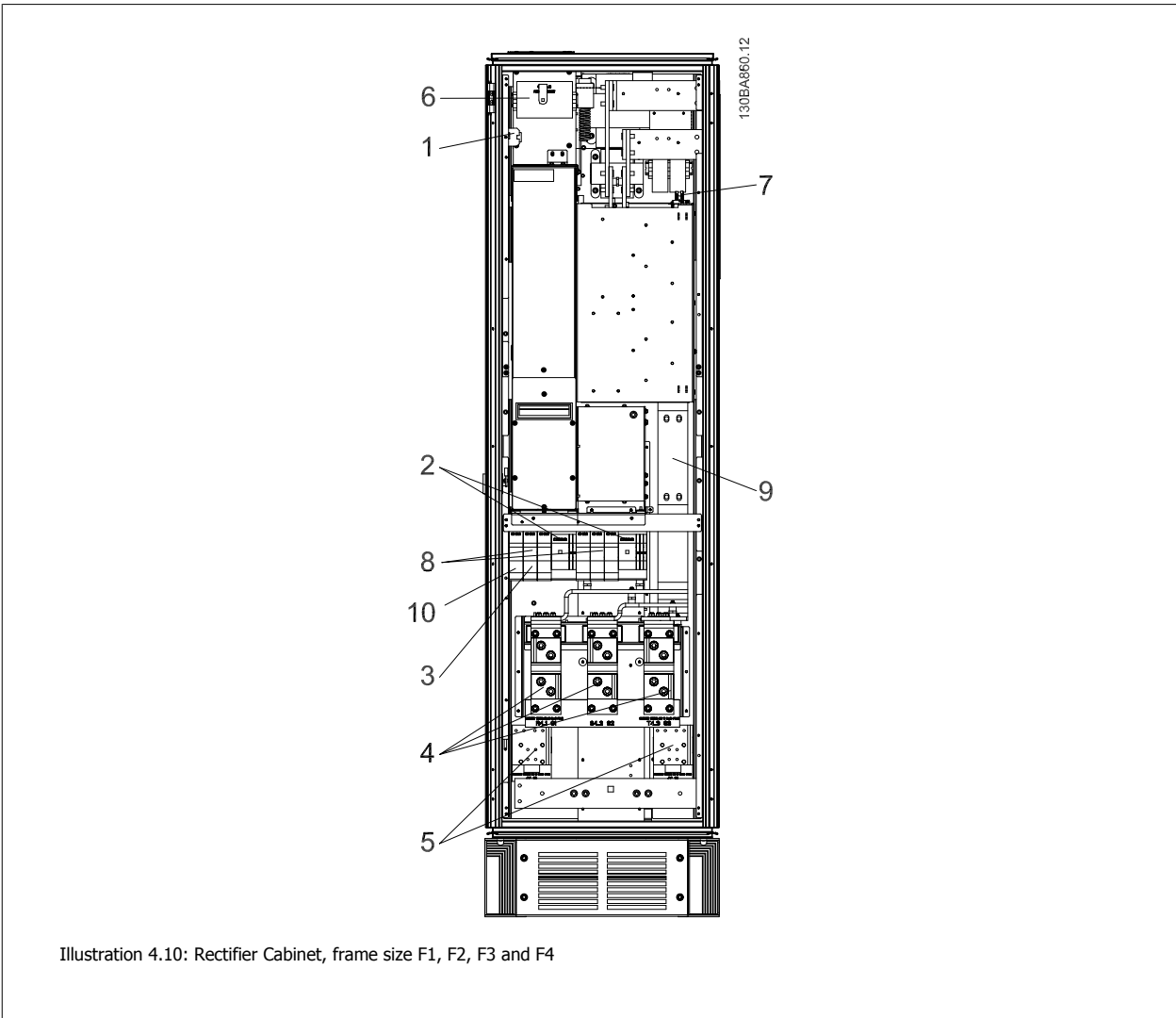

Illustration 4.10: Rectifier Cabinet, frame size F1, F2, F3 and F4

- |   |   |
|---|---|
| <p>1) 24 V DC, 5 A<br/>T1 Output Taps<br/>Temp Switch<br/>106 104 105</p> <p>2) Manual Motor Starters</p> <p>3) 30 A Fuse Protected Power Terminals</p> <p>4) Line<br/>R S T<br/>L1 L2 L3</p> | <p>5) Loadsharing<br/>-DC +DC<br/>88 89</p> <p>6) Control Transformer Fuses (2 or 4 pieces). See fuse tables for part numbers</p> <p>7) SMPS Fuse. See fuse tables for part numbers</p> <p>8) Manual Motor Controller fuses (3 or 6 pieces). See fuse tables for part numbers</p> <p>9) Line Fuses, F1 and F2 frame (3 pieces). See fuse tables for part numbers</p> <p>10) 30 Amp Fuse Protected Power fuses</p> |
|---|---|

4

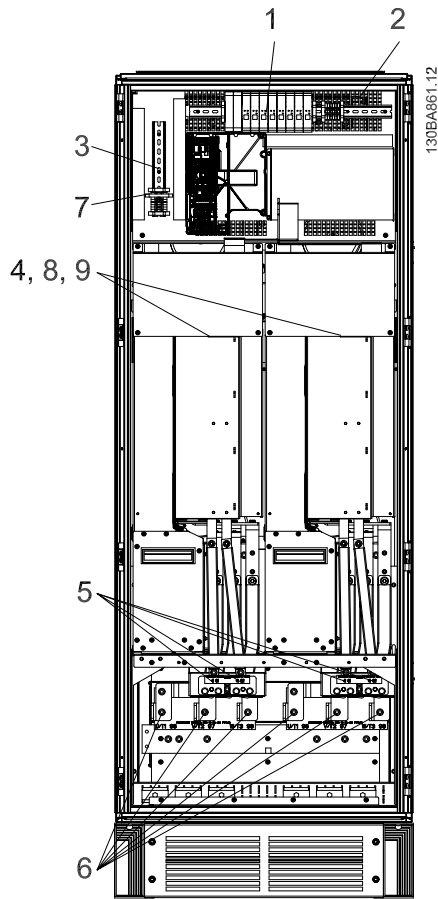

Illustration 4.11: Inverter Cabinet, frame size F1 and F3

- 1) External Temperature Monitoring
- 2) AUX Relay
  - 01 02 03
  - 04 05 06
- 3) NAMUR
- 4) AUX Fan
  - 100 101 102 103
  - L1 L2 L1 L2
- 5) Brake
  - R +R
  - 81 82

- 6) Motor
 

U	V	W
96	97	98
T1	T2	T3
- 7) NAMUR Fuse. See fuse tables for part numbers
- 8) Fan Fuses. See fuse tables for part numbers
- 9) SMPS Fuses. See fuse tables for part numbers

4

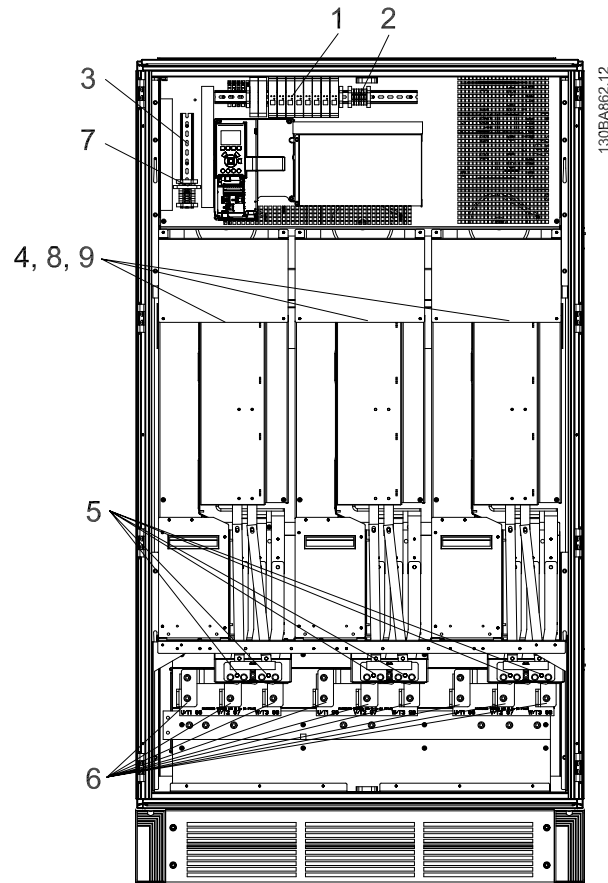

Illustration 4.12: Inverter Cabinet, frame size F2 and F4

- |                                    |   |
|------------------------------------|---|
| 1) External Temperature Monitoring | 6) Motor  |
| 2) AUX Relay                       | U    V    W                                     |
| 01  02  03                         | 96  97  98                                      |
| 04  05  06                         | T1  T2  T3                                      |
| 3) NAMUR                           | 7) NAMUR Fuse. See fuse tables for part numbers |
| 4) AUX Fan                         | 8) Fan Fuses. See fuse tables for part numbers  |
| 100  101  102  103                 | 9) SMPS Fuses. See fuse tables for part numbers |
| L1  L2  L1  L2                     |   |
| 5) Brake                           |   |
| -R  +R                             |   |
| 81  82                             |   |

4

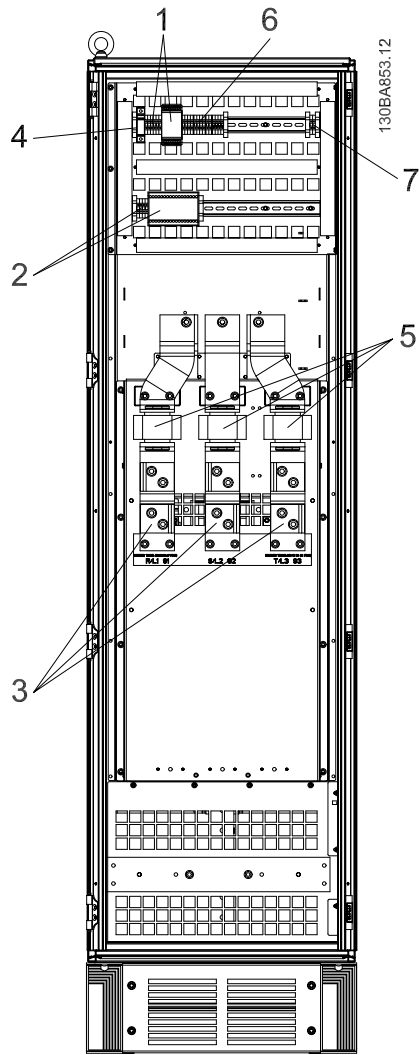

Illustration 4.13: Options Cabinet, frame size F3 and F4

- |  |    |    |   |    |    |    |    |    |    |   |
|--|----|----|---|----|----|----|----|----|----|---|
| <ul style="list-style-type: none"> <li>1) Pilz Relay Terminal</li> <li>2) RCD or IRM Terminal</li> <li>3) Mains                         <table border="0" style="margin-left: 20px;"> <tr> <td>R</td> <td>S</td> <td>T</td> </tr> <tr> <td>91</td> <td>92</td> <td>93</td> </tr> <tr> <td>L1</td> <td>L2</td> <td>L3</td> </tr> </table> </li> </ul> | R  | S  | T | 91 | 92 | 93 | L1 | L2 | L3 | <ul style="list-style-type: none"> <li>4) Safety Relay Coil Fuse with PILS Relay<br/>See fuse tables for part numbers</li> <li>5) Line Fuses, F3 and F4 (3 pieces)<br/>See fuse tables for part numbers</li> <li>6) Contactor Relay Coil (230 VAC). N/C and N/O Aux Contacts</li> <li>7) Circuit Breaker Shunt Trip Control Terminals (230 VAC or 230 VDC)</li> </ul> |
| R  | S  | T  |   |    |    |    |    |    |    |   |
| 91   | 92 | 93 |   |    |    |    |    |    |    |   |
| L1   | L2 | L3 |   |    |    |    |    |    |    |   |

### 4.1.2 Earthing

The following basic issues need to be considered when installing a frequency converter, so as to obtain electromagnetic compatibility (EMC).

- Safety earthing: Please note that the frequency converter has a high leakage current and must be earthed appropriately for safety reasons. Apply local safety regulations.
- High-frequency earthing: Keep the earth wire connections as short as possible.

Connect the different earth systems at the lowest possible conductor impedance. The lowest possible conductor impedance is obtained by keeping the conductor as short as possible and by using the greatest possible surface area.

The metal cabinets of the different devices are mounted on the cabinet rear plate using the lowest possible HF impedance. This avoids having different HF voltages for the individual devices and avoids the risk of radio interference currents running in connection cables that may be used between the devices. The radio interference will have been reduced.

In order to obtain a low HF impedance, use the fastening bolts of the devices as HF connection to the rear plate. It is necessary to remove insulating paint or similar from the fastening points.

4

### 4.1.3 Extra Protection (RCD)

ELCB relays, multiple protective earthing or earthing can be used as extra protection, provided that local safety regulations are complied with.

In the case of an earth fault, a DC component may develop in the fault current.

If ELCB relays are used, local regulations must be observed. Relays must be suitable for protection of 3-phase equipment with a bridge rectifier and for a brief discharge on power-up.

See also the section *Special Conditions* in the Design Guide.

### 4.1.4 RFI Switch

#### Mains supply isolated from earth

If the frequency converter is supplied from an isolated mains source ( IT mains, floating delta and grounded delta) or TT/TN-S mains with grounded leg, the RFI switch is recommended to be turned off (OFF) <sup>1)</sup> via par. 14-50 *RFI Filter*. For further reference, see IEC 364-3. In case optimum EMC performance is needed, parallel motors are connected or the motor cable length is above 25 m, it is recommended to set par. 14-50 *RFI Filter* to [ON].

<sup>1)</sup> Not available for 525-600/690 V frequency converters in frame sizes D, E and F.

In OFF, the internal RFI capacities (filter capacitors) between the chassis and the intermediate circuit are cut off to avoid damage to the intermediate circuit and to reduce the earth capacity currents (according to IEC 61800-3).

Please also refer to the application note *VLT on IT mains, MN.90.CX.02*. It is important to use isolation monitors that are capable for use together with power electronics (IEC 61557-8).

4

### 4.1.5 Torque

When tightening all electrical connections it is very important to tighten with the correct torque. Too low or too high torque results in a bad electrical connection. Use a torque wrench to ensure correct torque

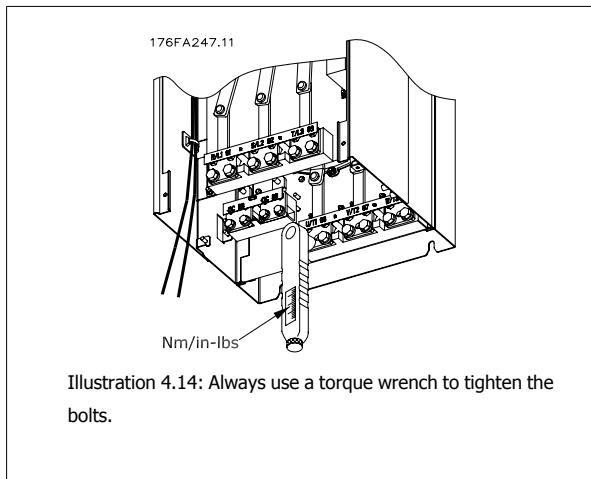

Frame size	Terminal	Torque	Bolt size
D1, D2, D3 and D4	Mains	19 Nm (168 in-lbs)	M10
	Motor		
	Load sharing	9.5 Nm (84 in-lbs)	M8
	Brake		
E1 and E2	Mains	19 NM (168 in-lbs)	M10
	Motor		
	Load sharing	9.5 Nm (84 in-lbs)	M8
	Brake		
F1, F2, F3 and F4	Mains	19 Nm (168 in-lbs)	M10
	Motor		
	Load sharing	19 Nm (168 in-lbs)	M10
	Brake	9.5 Nm (84 in-lbs)	M8
	Regen	19 Nm (168 in-lbs)	M10

Table 4.1: Torque for terminals

### 4.1.6 Shielded Cables

It is important that shielded and armoured cables are connected in a proper way to ensure high EMC immunity and low emissions.

Connection can be made using either cable glands or clamps:

- EMC cable glands: Generally available cable glands can be used to ensure an optimum EMC connection.
- EMC cable clamp: Clamps allowing easy connection are supplied with the frequency converter.

### 4.1.7 Motor Cable

The motor must be connected to terminals U/T1/96, V/T2/97, W/T3/98. Earth to terminal 99. All types of three-phase asynchronous standard motors can be used with a frequency converter unit. The factory setting is for clockwise rotation with the frequency converter output connected as follows:

Terminal No.	Function
96, 97, 98, 99	Mains U/T1, V/T2, W/T3
	Earth

- Terminal U/T1/96 connected to U-phase
- Terminal V/T2/97 connected to V-phase
- Terminal W/T3/98 connected to W-phase

The direction of rotation can be changed by switching two phases in the motor cable or by changing the setting of par. 4-10 *Motor Speed Direction*. Motor rotation check can be performed using par.1-28 *Motor Rotation Check* and following the steps shown in the display.

**F frame Requirements**

**F1/F3 requirements:** Motor phase cable quantities must be multiples of 2, resulting in 2, 4, 6, or 8 (1 cable is not allowed) to obtain equal amount of wires attached to both inverter module terminals. The cables are required to be equal length within 10% between the inverter module terminals and the first common point of a phase. The recommended common point is the motor terminals.

**F2/F4 requirements:** Motor phase cable quantities must be multiples of 3, resulting in 3, 6, 9, or 12 (1 or 2 cables are not allowed) to obtain equal amount of wires attached to each inverter module terminal. The wires are required to be equal length within 10% between the inverter module terminals and the first common point of a phase. The recommended common point is the motor terminals.

**Output junction box requirements:** The length, minimum 2.5 meters, and quantity of cables must be equal from each inverter module to the common terminal in the junction box.

**4.1.8 Brake Cable Drives with Factory Installed Brake Chopper Option**

(Only standard with letter B in position 18 of typecode).

The connection cable to the brake resistor must be screened and the max. length from frequency converter to the DC bar is limited to 25 metres (82 feet).

Terminal No.	Function
81, 82	Brake resistor terminals

The connection cable to the brake resistor must be screened. Connect the screen by means of cable clamps to the conductive back plate at the frequency converter and to the metal cabinet of the brake resistor.

Size the brake cable cross-section to match the brake torque. See also *Brake Instructions, MI.90.Fx.yy* and *MI.50.Sx.yy* for further information regarding safe installation.

Please note that voltages up to 1099 VDC, depending on the supply voltage, may occur on the terminals.

**F Frame Requirements**

The brake resistor(s) must be connected to the brake terminals in each inverter module.

4

### 4.1.9 Brake Resistor Temperature Switch

**Frame size D-E-F**

Torque: 0.5-0.6 Nm (5 in-lbs)

Screw size: M3

This input can be used to monitor the temperature of an externally connected brake resistor. If the input between 104 and 106 is established, the frequency converter will trip on warning / alarm 27, "Brake IGBT". If the connection is closed between 104 and 105, the frequency converter will trip on warning / alarm 27, "Brake IGBT".

Normally closed: 104-106 (factory installed jumper)

Normally open: 104-105

Terminal No.	Function
106, 104, 105	Brake resistor temperature switch.

 If the temperature of the brake resistor gets too high and the thermal switch drops out, the frequency converter will stop braking. The motor will start coasting. A KLIXON switch must be installed that is 'normally closed'. If this function is not used, 106 and 104 must be short-circuited together.

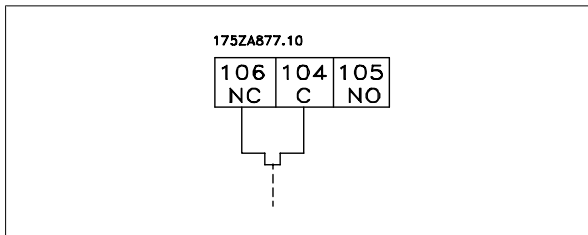



### 4.1.10 Load Sharing

Terminal No.	Function
88, 89	Loadsharing

The connection cable must be screened and the max. length from the frequency converter to the DC bar is limited to 25 metres (82 feet).

Load sharing enables linking of the DC intermediate circuits of several frequency converters.

 Please note that voltages up to 1099 VDC may occur on the terminals. Load Sharing calls for extra equipment and safety considerations. For further information, see load sharing Instructions MI.50.NX.YY.

 Please note that mains disconnect may not isolate the frequency converter due to DC link connection



### 4.1.11 Shielding against Electrical Noise

Before mounting the mains power cable, mount the EMC metal cover to ensure best EMC performance.

NOTE: The EMC metal cover is only included in units with an RFI filter.

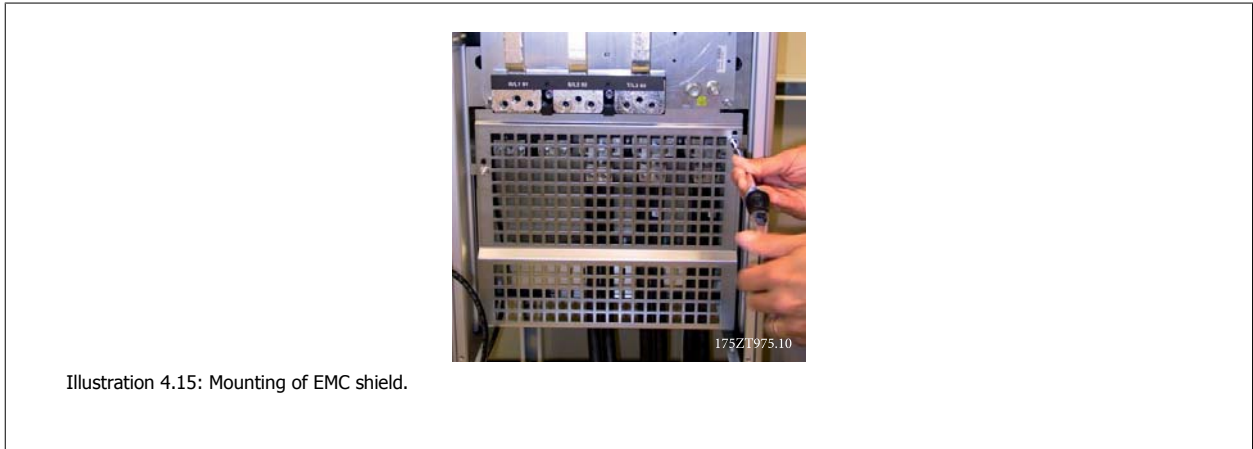

Illustration 4.15: Mounting of EMC shield.

### 4.1.12 Mains Connection

Mains must be connected to terminals 91, 92 and 93. Earth is connected to the terminal to the right of terminal 93.

Terminal No.	Function
91, 92, 93	Mains R/L1, S/L2, T/L3
94	Earth

Check the name plate to ensure that the mains voltage of the frequency converter matches the power supply of your plant.

Ensure that the power supply can supply the necessary current to the frequency converter.

If the unit is without built-in fuses, ensure that the appropriate fuses have the correct current rating.

### 4.1.13 External Fan Supply

#### Frame size D-E-F

In case the frequency converter is supplied by DC or if the fan must run independently of the power supply, an external power supply can be applied. The connection is made on the power card.

Terminal No.	Function
100, 101	Auxiliary supply S, T
102, 103	Internal supply S, T

The connector located on the power card provides the connection of line voltage for the cooling fans. The fans are connected from factory to be supplied from a common AC line (jumpers between 100-102 and 101-103). If external supply is needed, the jumpers are removed and the supply is connected to terminals 100 and 101. A 5 Amp fuse should be used for protection. In UL applications this should be LittleFuse KLK-5 or equivalent.

#### 4.1.14 Fuses

##### Branch circuit protection:

In order to protect the installation against electrical and fire hazard, all branch circuits in an installation, switch gear, machines etc., must be short-circuited and over-current protected according to national/international regulations.

##### Short-circuit protection:

The frequency converter must be protected against short-circuit to avoid electrical or fire hazard. Armstrong recommends using the fuses mentioned below to protect service personnel and equipment in case of an internal failure in the drive. The frequency converter provides full short-circuit protection in case of a short-circuit on the motor output.

##### Over-current protection

Provide overload protection to avoid fire hazard due to overheating of the cables in the installation. The frequency converter is equipped with an internal over-current protection that can be used for upstream overload protection (UL-applications excluded). See par. 4-18 *Current Limit*. Moreover, fuses or circuit breakers can be used to provide the over-current protection in the installation. Over-current protection must always be carried out according to national regulations.

##### Non UL compliance

If UL/cUL is not to be complied with, we recommend using the following fuses, which will ensure compliance with EN50178:

P110 - P250	380 - 480 V	type gG
P315 - P450	380 - 480 V	type gR

##### 380-480 V, frame sizes D, E and F

The fuses below are suitable for use on a circuit capable of delivering 100,000 Arms (symmetrical), 240V, or 480V, or 500V, or 600V depending on the drive voltage rating. With the proper fusing the drive Short Circuit Current Rating (SCCR) is 100,000 Arms.

Size/ Type	Bussmann E1958 JFHR2**	Bussmann E4273 T/JDDZ**	SIBA E180276 JFHR2	LittelFuse E71611 JFHR2**	Ferraz- Shawmut E60314 JFHR2**	Bussmann E4274 H/JDDZ**	Bussmann E125085 JFHR2*	Internal Option Bussmann
P110	FWH- 300	JJS- 300	2061032.315	L50S-300	A50-P300	NOS- 300	170M3017	170M3018
P132	FWH- 350	JJS- 350	2061032.35	L50S-350	A50-P350	NOS- 350	170M3018	170M3018
P160	FWH- 400	JJS- 400	2061032.40	L50S-400	A50-P400	NOS- 400	170M4012	170M4016
P200	FWH- 500	JJS- 500	2061032.50	L50S-500	A50-P500	NOS- 500	170M4014	170M4016
P250	FWH- 600	JJS- 600	2062032.63	L50S-600	A50-P600	NOS- 600	170M4016	170M4016

Table 4.2: Frame size D, Line fuses, 380-480 V

Size/Type	Bussmann PN*	Rating	Ferraz	Siba
P315	170M4017	700 A, 700 V	6.9URD31D08A0700	20 610 32.700
P355	170M6013	900 A, 700 V	6.9URD33D08A0900	20 630 32.900
P400	170M6013	900 A, 700 V	6.9URD33D08A0900	20 630 32.900
P450	170M6013	900 A, 700 V	6.9URD33D08A0900	20 630 32.900

Table 4.3: Frame size E, Line fuses, 380-480 V

Size/Type	Bussmann PN*	Rating	Siba	Internal Bussmann Option
P500	170M7081	1600 A, 700 V	20 695 32.1600	170M7082
P560	170M7081	1600 A, 700 V	20 695 32.1600	170M7082
P630	170M7082	2000 A, 700 V	20 695 32.2000	170M7082
P710	170M7082	2000 A, 700 V	20 695 32.2000	170M7082
P800	170M7083	2500 A, 700 V	20 695 32.2500	170M7083
P1M0	170M7083	2500 A, 700 V	20 695 32.2500	170M7083

Table 4.4: Frame size F, Line fuses, 380-480 V

Size/Type	Bussmann PN*	Rating	Siba
P500	170M8611	1100 A, 1000 V	20 781 32.1000
P560	170M8611	1100 A, 1000 V	20 781 32.1000
P630	170M6467	1400 A, 700 V	20 681 32.1400
P710	170M6467	1400 A, 700 V	20 681 32.1400
P800	170M8611	1100 A, 1000 V	20 781 32.1000
P1M0	170M6467	1400 A, 700 V	20 681 32.1400

Table 4.5: Frame size F, Inverter module DC Link Fuses, 380-480 V

\*170M fuses from Bussmann shown use the -/80 visual indicator, -TN/80 Type T, -/110 or TN/110 Type T indicator fuses of the same size and amperage may be substituted for external use

\*\*Any minimum 500 V UL listed fuse with associated current rating may be used to meet UL requirements.

**525-690 V, frame sizes D, E and F**

Size/Type	Bussmann E125085 JFHR2	Amps	SIBA E180276 JFHR2	Ferraz-Shawmut E76491 JFHR2	Internal Option Bussmann
P45K	170M3013	125	2061032.125	6.6URD30D08A0125	170M3015
P55K	170M3014	160	2061032.16	6.6URD30D08A0160	170M3015
P75K	170M3015	200	2061032.2	6.6URD30D08A0200	170M3015
P90K	170M3015	200	2061032.2	6.6URD30D08A0200	170M3015
P110	170M3016	250	2061032.25	6.6URD30D08A0250	170M3018
P132	170M3017	315	2061032.315	6.6URD30D08A0315	170M3018
P160	170M3018	350	2061032.35	6.6URD30D08A0350	170M3018
P200	170M4011	350	2061032.35	6.6URD30D08A0350	170M5011
P250	170M4012	400	2061032.4	6.6URD30D08A0400	170M5011
P315	170M4014	500	2061032.5	6.6URD30D08A0500	170M5011
P400	170M5011	550	2062032.55	6.6URD32D08A550	170M5011

Table 4.6: Frame size D, 525-690 V

Size/Type	Bussmann PN*	Rating	Ferraz	Siba
P450	170M4017	700 A, 700 V	6.9URD31D08A0700	20 610 32.700
P500	170M4017	700 A, 700 V	6.9URD31D08A0700	20 610 32.700
P560	170M6013	900 A, 700 V	6.9URD33D08A0900	20 630 32.900
P630	170M6013	900 A, 700 V	6.9URD33D08A0900	20 630 32.900

Table 4.7: Frame size E, 525-690 V

Size/Type	Bussmann PN*	Rating	Siba	Internal Bussmann Option
P710	170M7081	1600 A, 700 V	20 695 32.1600	170M7082
P800	170M7081	1600 A, 700 V	20 695 32.1600	170M7082
P900	170M7081	1600 A, 700 V	20 695 32.1600	170M7082
P1M0	170M7081	1600 A, 700 V	20 695 32.1600	170M7082
P1M2	170M7082	2000 A, 700 V	20 695 32.2000	170M7082
P1M4	170M7083	2500 A, 700 V	20 695 32.2500	170M7083

Table 4.8: Frame size F, Line fuses, 525-690 V

Size/Type	Bussmann PN*	Rating	Siba
P710	170M8611	1100 A, 1000 V	20 781 32. 1000
P800	170M8611	1100 A, 1000 V	20 781 32. 1000
P900	170M8611	1100 A, 1000 V	20 781 32. 1000
P1M0	170M8611	1100 A, 1000 V	20 781 32. 1000
P1M2	170M8611	1100 A, 1000 V	20 781 32. 1000
P1M4	170M8611	1100 A, 1000 V	20 781 32.1000

Table 4.9: Frame size F, Inverter module DC Link Fuses, 525-690 V

\*170M fuses from Bussmann shown use the -/80 visual indicator, -TN/80 Type T, -/110 or TN/110 Type T indicator fuses of the same size and amperage may be substituted for external use.

Suitable for use on a circuit capable of delivering not more than 100 000 rms symmetrical amperes, 500/600/690 Volts maximum when protected by the above fuses.

**Supplementary fuses**

Frame size	Bussmann PN*	Rating
D, E and F	KTK-4	4 A, 600 V

Table 4.10: SMPS Fuse

Size/Type	Bussmann PN*	Littelfuse	Rating
P110-P315, 380-480 V	KTK-4		4 A, 600 V
P45K-P500, 525-690 V	KTK-4		4 A, 600 V
P355-P1M0, 380-480 V		KLK-15	15A, 600 V
P560-P1M4, 525-690 V		KLK-15	15A, 600 V

Table 4.11: Fan Fuses

Size/Type	Bussmann PN*	Rating	Alternative Fuses
P500-P1M0, 380-480 V 2.5-4.0 A	LPJ-6 SP or SPI	6 A, 600 V	Any listed Class J Dual Element, Time Delay, 6A
P710-P1M4, 525-690 V	LPJ-10 SP or SPI	10 A, 600 V	Any listed Class J Dual Element, Time Delay, 10 A
P500-P1M0, 380-480 V 4.0-6.3 A	LPJ-10 SP or SPI	10 A, 600 V	Any listed Class J Dual Element, Time Delay, 10 A
P710-P1M4, 525-690 V	LPJ-15 SP or SPI	15 A, 600 V	Any listed Class J Dual Element, Time Delay, 15 A
P500-P1M0, 380-480 V 6.3 - 10 A	LPJ-15 SP or SPI	15 A, 600 V	Any listed Class J Dual Element, Time Delay, 15 A
P710-P1M4, 525-690 V	LPJ-20 SP or SPI	20 A, 600 V	Any listed Class J Dual Element, Time Delay, 20A
P500-P1M0, 380-480 V 10 - 16 A	LPJ-25 SP or SPI	25 A, 600 V	Any listed Class J Dual Element, Time Delay, 25 A
P710-P1M4, 525-690 V	LPJ-20 SP or SPI	20 A, 600 V	Any listed Class J Dual Element, Time Delay, 20 A

Table 4.12: Manual Motor Controller Fuses

Frame size	Bussmann PN*	Rating	Alternative Fuses
F	LPJ-30 SP or SPI	30 A, 600 V	Any listed Class J Dual Element, Time Delay, 30 A

Table 4.13: 30 A Fuse Protected Terminal Fuse

Frame size	Bussmann PN*	Rating	Alternative Fuses
F	LPJ-6 SP or SPI	6 A, 600 V	Any listed Class J Dual Element, Time Delay, 6 A

Table 4.14: Control Transformer Fuse

Frame size	Bussmann PN*	Rating
F	GMC-800MA	800 mA, 250 V

Table 4.15: NAMUR Fuse

Frame size	Bussmann PN*	Rating	Alternative Fuses
F	LP-CC-6	6 A, 600 V	Any listed Class CC, 6 A

Table 4.16: Safety Relay Coil Fuse with PILS Relay

4

#### 4.1.15 Mains Disconnectors - Frame Size D, E and F

Frame size	Power & Voltage	Type
D1/D3	P110-P132 380-480V & P110-P160 525-690V	ABB OETL-NF200A or OT200U12-91
D2/D4	P160-P250 380-480V & P200-P400 525-690V	ABB OETL-NF400A or OT400U12-91
E1/E2	P315 380-480V & P450-P630 525-690V	ABB OETL-NF600A
E1/E2	P355-P450 380-480V	ABB OETL-NF800A
F3	P500 380-480V & P710-P800 525-690V	Merlin Gerin NPJF36000S12AAYP
F3	P560-P710 380-480V & P900 525-690V	Merlin Gerin NRK36000S20AAYP
F4	P800-P1M0 380-480V & P1M0-P1M4 525-690V	Merlin Gerin NRK36000S20AAYP

#### 4.1.16 F Frame circuit breakers

Frame size	Power & Voltage	Type
F3	P500 380-480V & P710-P800 525-690V	Merlin Gerin NPJF36120U31AABSCYP
F3	P630-P710 380-480V & P900 525-690V	Merlin Gerin NRJF36200U31AABSCYP
F4	P800 380-480V & P1M0-P1M2 525-690V	Merlin Gerin NRJF36200U31AABSCYP
F4	P1M0 380-480V	Merlin Gerin NRJF36250U31AABSCYP

#### 4.1.17 F Frame Mains Contactors

Frame size	Power & Voltage	Type
F3	P500-P560 380-480V & P710-P900 525-690V	Eaton XTCE650N22A
F3	P630 380-480V	Eaton XTCE820N22A
F3	P710 380-480V	Eaton XTCEC14P22B
F4	P1M0 525-690V	Eaton XTCE820N22A
F4	P800-P1M0 380-480V & P1M4 525-690V	Eaton XTCEC14P22B

#### 4.1.18 Motor Insulation

For motor cable lengths  $\leq$  the maximum cable length listed in the General Specifications tables the following motor insulation ratings are recommended because the peak voltage can be up to twice the DC link voltage, 2.8 times the mains voltage, due to transmission line effects in the motor cable. If a motor has lower insulation rating it recommended to use a du/dt or sine wave filter.

Nominal Mains Voltage	Motor Insulation
$U_N \leq 420$ V	Standard $U_{LL} = 1300$ V
$420$ V < $U_N \leq 500$ V	Reinforced $U_{LL} = 1600$ V
$500$ V < $U_N \leq 600$ V	Reinforced $U_{LL} = 1800$ V
$600$ V < $U_N \leq 690$ V	Reinforced $U_{LL} = 2000$ V

#### 4.1.19 Motor Bearing Currents

All motors installed with 110 kW or higher power drives should have NDE (Non-Drive End) insulated bearings installed to eliminate circulating bearing currents. To minimize DE (Drive End) bearing and shaft currents proper grounding of the drive, motor, driven machine, and motor to the driven machine is required.

##### Standard Mitigation Strategies:

1. Use an insulated bearing
2. Apply rigorous installation procedures
  - Strictly follow the EMC Installation guideline

- Provide a good high frequency connection between the motor and the frequency converter for instance by screened cable which has a 360° connection in the motor and the frequency converter
  - Provide a low impedance path from frequency converter to building ground/earth and from the motor to building ground/earth. This can be difficult for pumps
  - Make a direct earth connection between the motor and load machine
  - Reinforce the PE so the high frequency impedance is lower in the PE
  - Ensure the motor and load motor are aligned
3. Lower the IGBT switching frequency
  4. Modify the inverter waveform, 60° AVM vs. SFAVM
  5. Install a shaft grounding system or use an isolating coupling between motor and load
  6. Apply conductive lubrication
  7. If the application allows, avoid running at low motor speeds by using the minimum speed settings of the drive .
  8. Try to ensure the line voltage is balanced to ground. This can be difficult for IT, TT, TN-CS or Grounded leg systems
  9. Use a dU/dt or sine wave filter

### 4.1.20 Control Cable Routing

Tie down all control wires to the designated control cable routing as shown in the picture. Remember to connect the shields in a proper way to ensure optimum electrical immunity.

#### Fieldbus connection

Connections are made to the relevant options on the control card. For details see the relevant fieldbus instruction. The cable must be placed to the left inside the frequency converter and tied down together with other control wires (see picture).

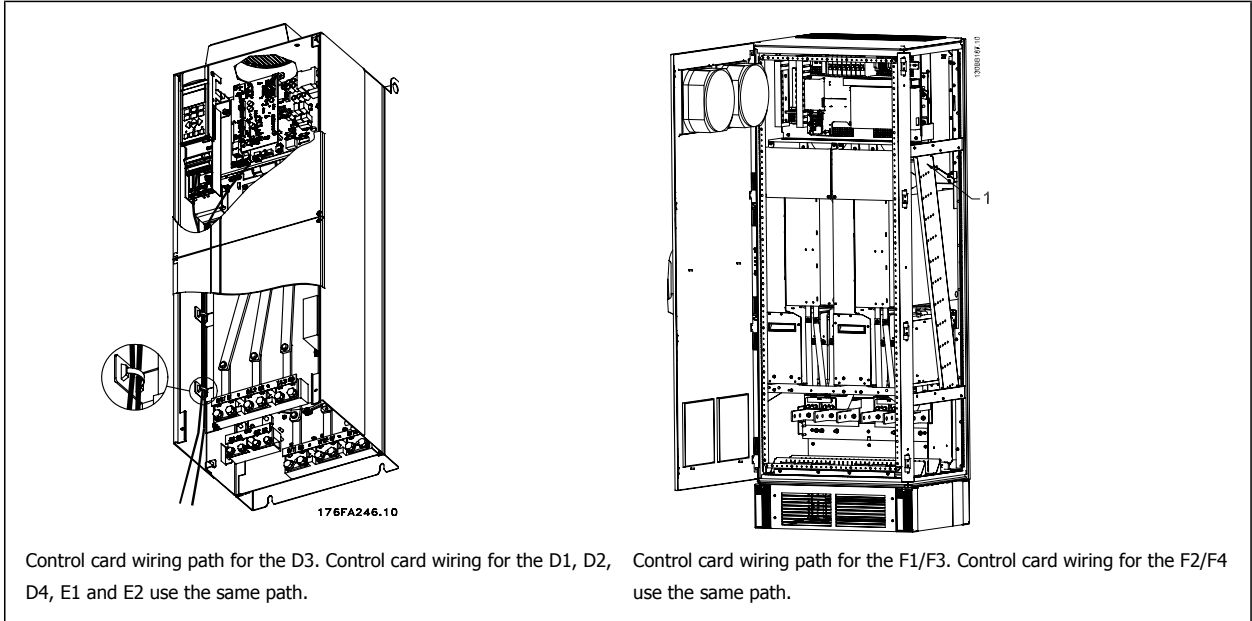

4

In the Chassis (IP00) and NEMA 1 units it is also possible to connect the fieldbus from the top of the unit as shown on the picture to the right. On the NEMA 1 unit a cover plate must be removed. Kit number for fieldbus top connection: 176F1742

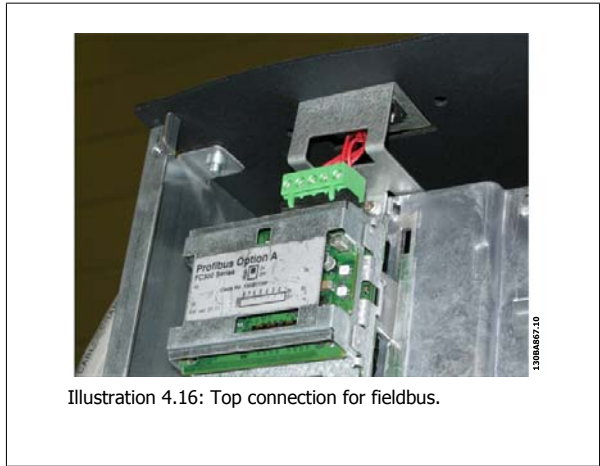

**Installation of 24 Volt external DC Supply**

Torque: 0.5 - 0.6 Nm (5 in-lbs)

Screw size: M3

No.	Function
35 (-), 36 (+)	24 V external DC supply

24 VDC external supply can be used as low-voltage supply to the control card and any option cards installed. This enables full operation of the LCP (including parameter setting) without connection to mains. Please note that a warning of low voltage will be given when 24 VDC has been connected; however, there will be no tripping.

**4**

Use 24 VDC supply of type PELV to ensure correct galvanic isolation (type PELV) on the control terminals of the frequency converter.

**4.1.21 Access to Control Terminals**

All terminals to the control cables are located beneath the LCP. They are accessed by opening the door of the IP21/ 54 version or removing the covers of the IP00 version.

**4.1.22 Electrical Installation, Control Terminals**

**To connect the cable to the terminal:**

1. Strip insulation by about 9-10 mm
2. Insert a screwdriver<sup>1)</sup> in the square hole.
3. Insert the cable in the adjacent circular hole.
4. Remove the screwdriver. The cable is now mounted in the terminal.

**To remove the cable from the terminal:**

1. Insert a screw driver<sup>1)</sup> in the square hole.
2. Pull out the cable.

<sup>1)</sup> Max. 0.4 x 2.5 mm

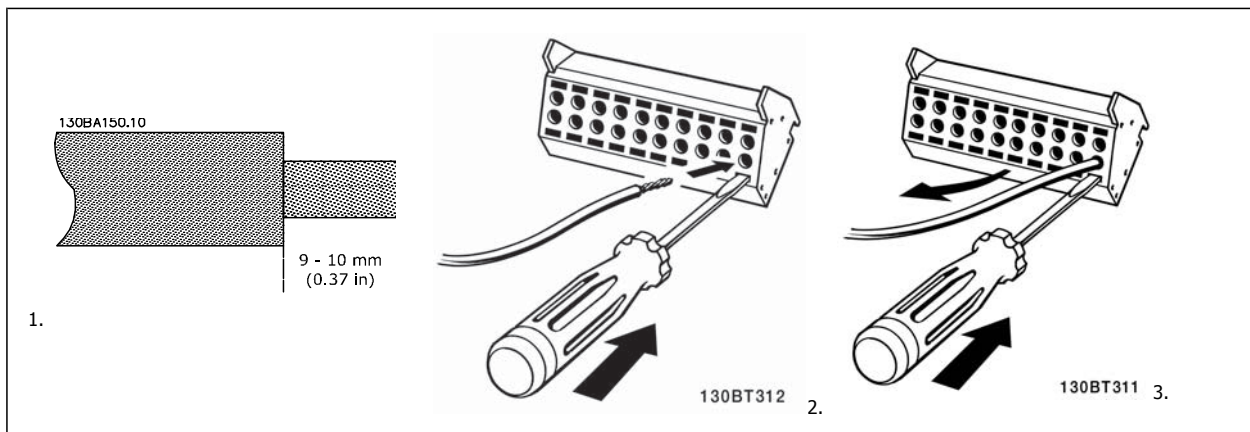



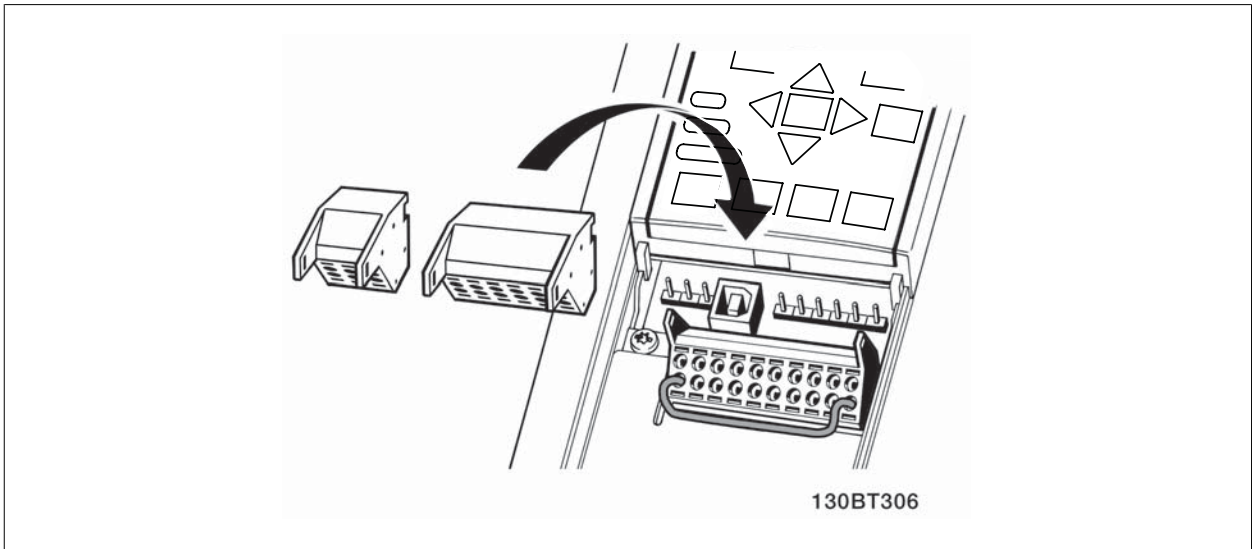

## 4.2 Connection Examples

### 4.2.1 Start/Stop

Terminal 18 = par. 5-10 *Terminal 18 Digital Input* [8] *Start*

Terminal 27 = par. 5-12 *Terminal 27 Digital Input* [0] *No operation* (Default *coast inverse*)

Terminal 37 = Safe stop

4

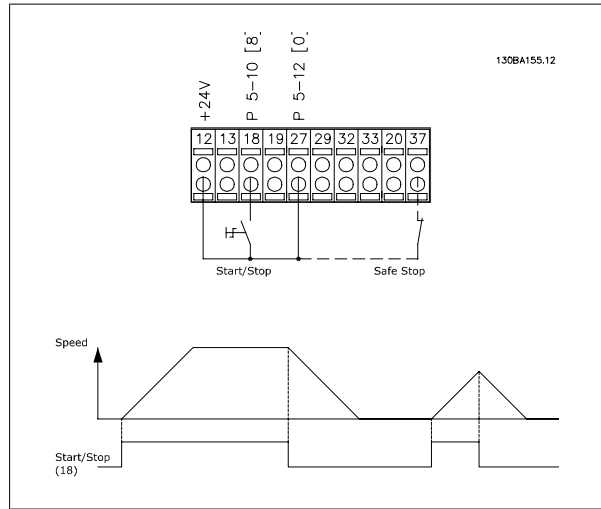

### 4.2.2 Pulse Start/Stop

Terminal 18 = par. 5-10 *Terminal 18 Digital Input* [9] *Latched start*

Terminal 27 = par. 5-12 *Terminal 27 Digital Input* [6] *Stop inverse*

Terminal 37 = Safe stop

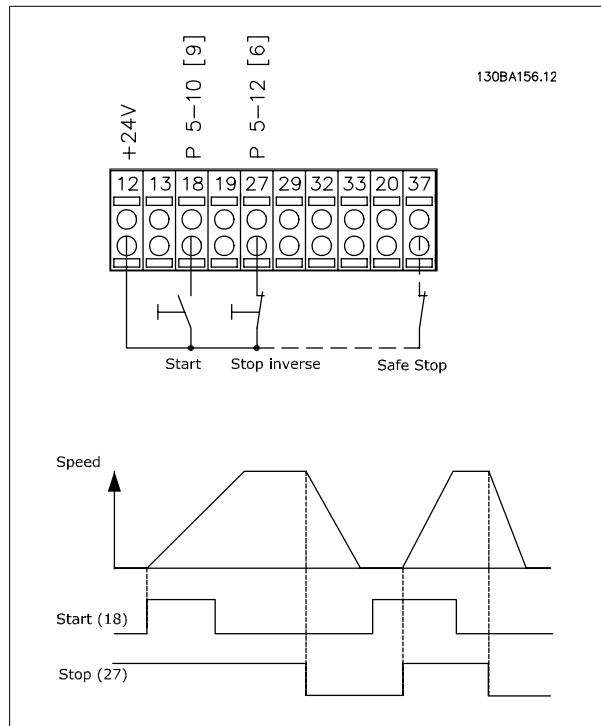

### 4.2.3 Speed Up/Down

**Terminals 29/32 = Speed up/down:**

Terminal 18 = par. 5-10 *Terminal 18 Digital Input* Start [9] (default)

Terminal 27 = par. 5-12 *Terminal 27 Digital Input* Freeze reference [19]

Terminal 29 = par. 5-13 *Terminal 29 Digital Input* Speed up [21]

Terminal 32 = par. 5-14 *Terminal 32 Digital Input* Speed down [22]

Note: Terminal 29 only in FC x02 (x=series type).

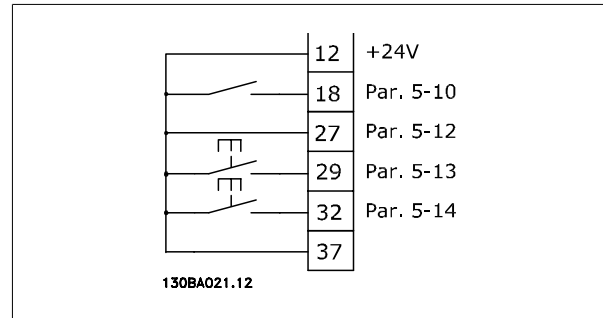

### 4.2.4 Potentiometer Reference

**Voltage reference via a potentiometer:**

Reference Source 1 = [1] *Analog input 53* (default)

Terminal 53, Low Voltage = 0 Volt

Terminal 53, High Voltage = 10 Volt

Terminal 53, Low Ref./Feedback = 0 RPM

Terminal 53, High Ref./Feedback = 1500 RPM

Switch S201 = OFF (U)

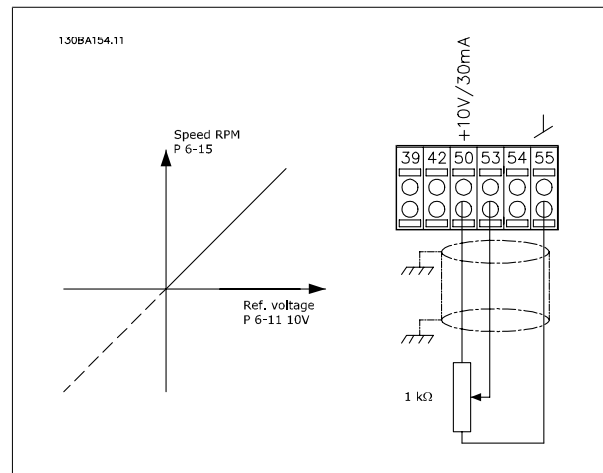

### 4.3 Electrical Installation - additional

#### 4.3.1 Electrical Installation, Control Cables

4

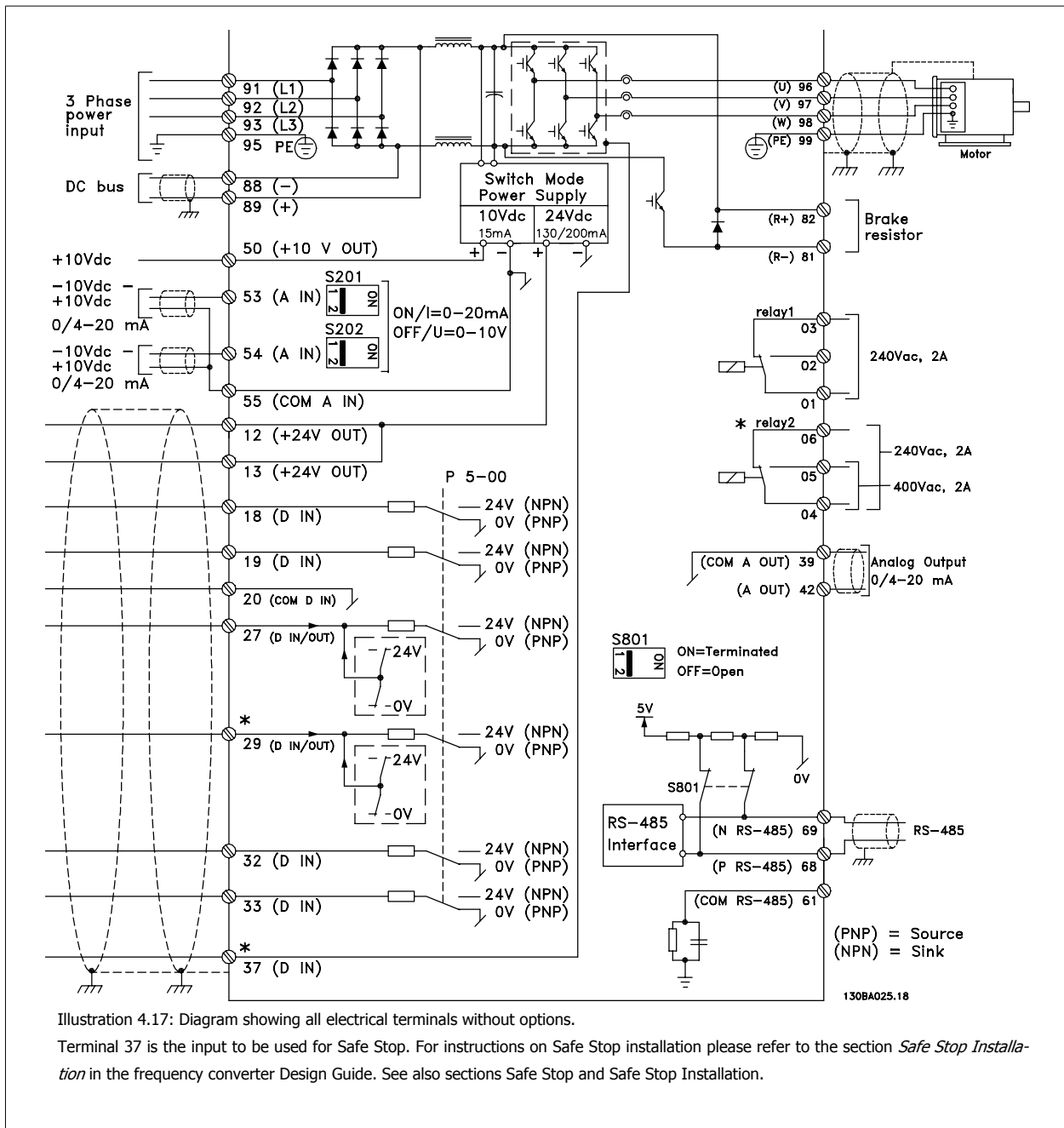

Very long control cables and analogue signals may in rare cases and depending on installation result in 50/60 Hz earth loops due to noise from mains supply cables.

If this occurs, it may be necessary to break the screen or insert a 100 nF capacitor between screen and chassis.

The digital and analog inputs and outputs must be connected separately to the frequency converter common inputs (terminal 20, 55, 39) to avoid earth currents from both groups to affect other groups. For example, switching on the digital input may disturb the analog input signal.

**Input polarity of control terminals**

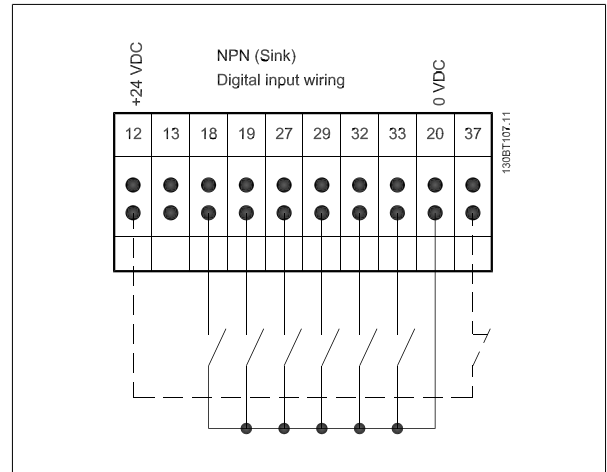
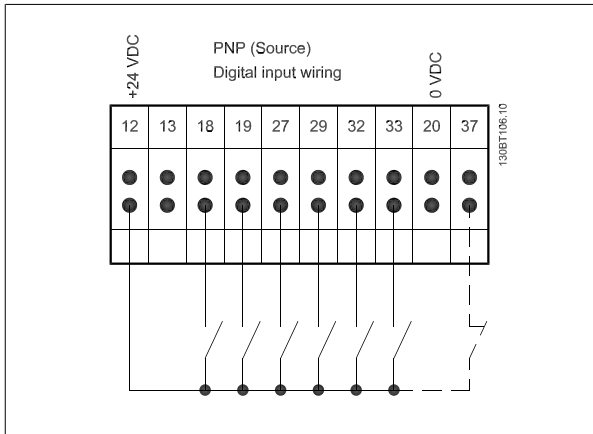

**4**

**NB!**  
Control cables must be screened/armoured.

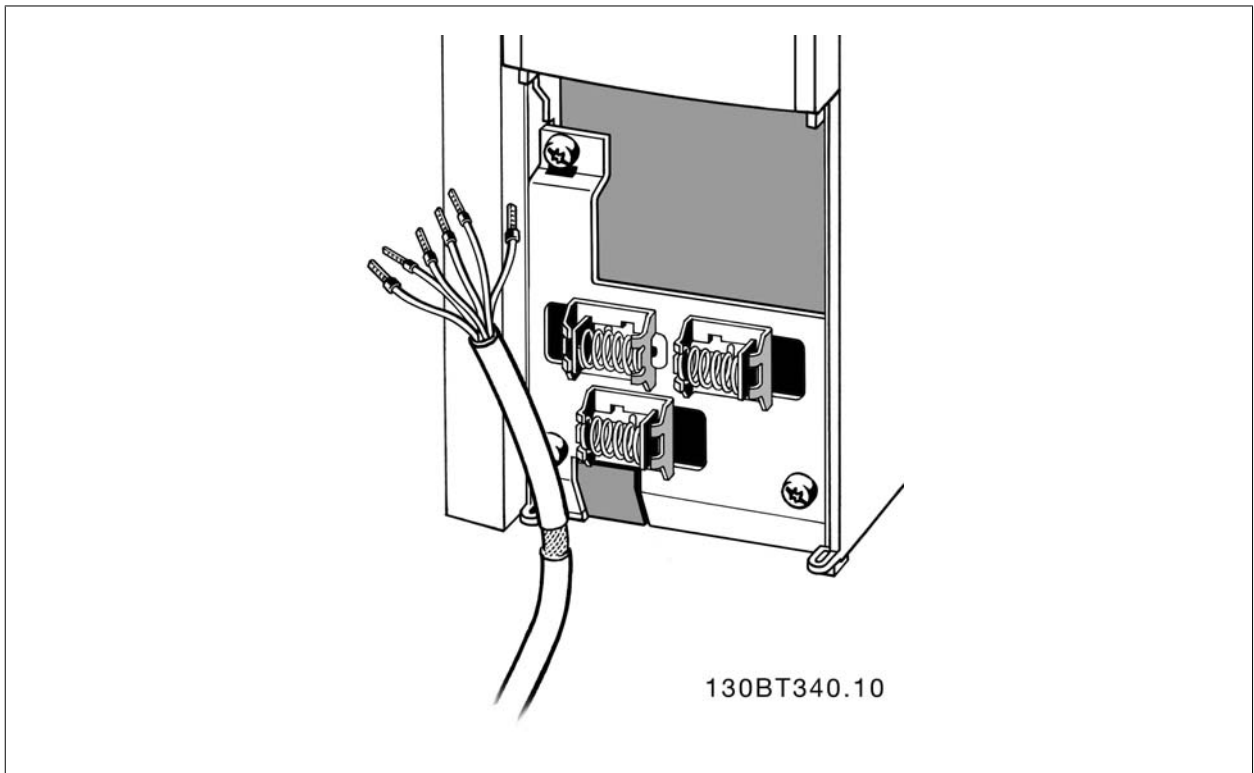

Connect the wires as described in the Operating Instruction for the frequency converter. Remember to connect the shields in a proper way to ensure optimum electrical immunity.

### 4.3.2 Switches S201, S202, and S801

Switches S201 (A53) and S202 (A54) are used to select a current (0-20 mA) or a voltage (-10 to 10 V) configuration of the analog input terminals 53 and 54 respectively.

Switch S801 (BUS TER.) can be used to enable termination on the RS-485 port (terminals 68 and 69).

See drawing *Diagram showing all electrical terminals* in section *Electrical Installation*.

**Default setting:**

S201 (A53) = OFF (voltage input)

S202 (A54) = OFF (voltage input)

S801 (Bus termination) = OFF



When changing the function of S201, S202 or S801 be careful not to use force for the switch over. It is recommended to remove the LCP fixture (cradle) when operating the switches. The switches must not be operated with power on the frequency converter.

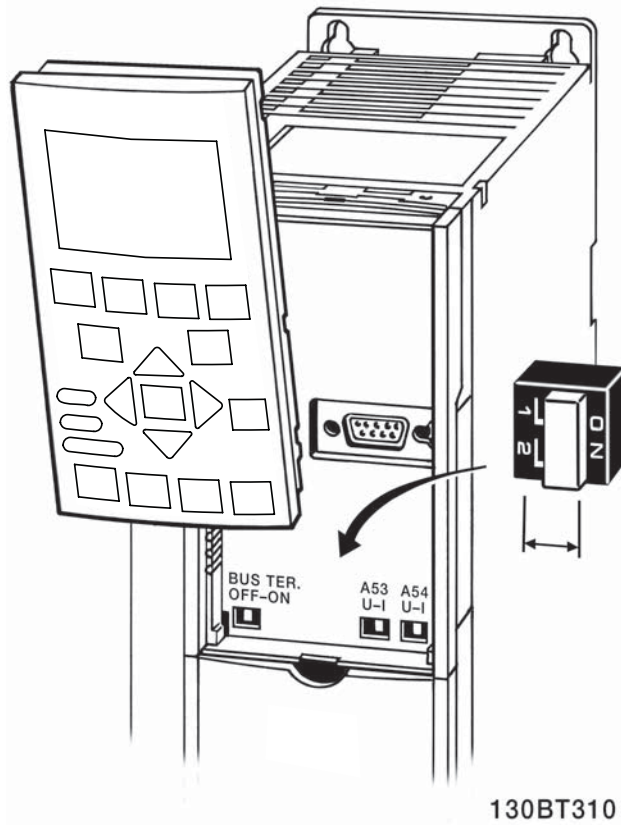

## 4.4 Final Set-up and Test

To test the set-up and ensure that the frequency converter is running, follow these steps.

### Step 1. Locate the motor name plate

**NB!**  
The motor is either star- (Y) or delta- connected ( $\Delta$ ). This information is located on the motor name plate data.

THREE PHASE INDUCTION MOTOR						
MOD MCV 315E	Nr.	135189 12 04			ILIN 6.5	
kW 400	PRIMARY			SF 1.15		
HP 536	V 690	A 410.6	CONN Y	COSf 0.85	40	
mm 1481	V	A	CONN	AMB 40	°C	
Hz 50	V	A	CONN	ALT 1000	m	
DESIGN N	SECONDARY			RISE 80 °C		
DUTY S1	V	A	CONN	ENCLOSURE IP23		
INSUL I	EFFICIENCY %	95.8%	100%	95.8%	75%	WEIGHT 1.83 ton
<b>⚠ CAUTION</b>						

130BA767.10

### Step 2. Enter the motor name plate data in this parameter list.

To access this list first press the [QUICK MENU] key then select "Q2 Quick Setup".

1.	Par. 1-20 <i>Motor Power [kW]</i> Par. 1-21 <i>Motor Power [HP]</i>
2.	Par. 1-22 <i>Motor Voltage</i>
3.	Par. 1-23 <i>Motor Frequency</i>
4.	Par. 1-24 <i>Motor Current</i>
5.	Par. 1-25 <i>Motor Nominal Speed</i>

### Step 3. Activate the Automatic Motor Adaptation (AMA)

Performing an AMA will ensure optimum performance. The AMA measures the values from the motor model equivalent diagram.

1. Connect terminal 37 to terminal 12 (if terminal 37 is available).
2. Connect terminal 27 to terminal 12 or set par. 5-12 *Terminal 27 Digital Input* to 'No function' (par. 5-12 *Terminal 27 Digital Input [0]*)
3. Activate the AMA par. 1-29 *Automatic Motor Adaptation (AMA)*.
4. Choose between complete or reduced AMA. If a Sine-wave filter is mounted, run only the reduced AMA, or remove the Sine-wave filter during the AMA procedure.
5. Press the [OK] key. The display shows "Press [Hand on] to start".
6. Press the [Hand on] key. A progress bar indicates if the AMA is in progress.

#### Stop the AMA during operation

1. Press the [OFF] key - the frequency converter enters into alarm mode and the display shows that the AMA was terminated by the user.

#### Successful AMA

1. The display shows "Press [OK] to finish AMA".
2. Press the [OK] key to exit the AMA state.

**Unsuccessful AMA**

1. The frequency converter enters into alarm mode. A description of the alarm can be found in the *Warnings and Alarms* chapter.
2. "Report Value" in the [Alarm Log] shows the last measuring sequence carried out by the AMA, before the frequency converter entered alarm mode. This number along with the description of the alarm will assist you in troubleshooting. If you contact Armstrong for service, make sure to mention number and alarm description.



**NB!**

Unsuccessful AMA is often caused by incorrectly registered motor name plate data or a too big difference between the motor power size and the frequency converter power size.

**4**

**Step 4. Set speed limit and ramp time**

Par. 3-02 *Minimum Reference*  
 Par. 3-03 *Maximum Reference*

Table 4.17: Set up the desired limits for speed and ramp time.

Par. 4-11 *Motor Speed Low Limit [RPM]* or par. 4-12 *Motor Speed Low Limit [Hz]*  
 Par. 4-13 *Motor Speed High Limit [RPM]* or par. 4-14 *Motor Speed High Limit [Hz]*

Par. 3-41 *Ramp 1 Ramp up Time*  
 Par. 3-42 *Ramp 1 Ramp Down Time*



## 4.5 Additional Connections

### 4.5.1 Mechanical Brake Control

In hoisting/lowering applications, it is necessary to be able to control an electro-mechanical brake:

- Control the brake using any relay output or digital output (terminal 27 or 29).
- Keep the output closed (voltage-free) as long as the frequency converter is unable to 'support' the motor, for example due to the load being too heavy.
- Select *Mechanical brake control* [32] in par. 5-4\* for applications with an electro-mechanical brake.
- The brake is released when the motor current exceeds the preset value in par. 2-20 *Release Brake Current*.
- The brake is engaged when the output frequency is less than the frequency set in par. 2-21 *Activate Brake Speed [RPM]* or par. 2-22 *Activate Brake Speed [Hz]*, and only if the frequency converter carries out a stop command.

If the frequency converter is in alarm mode or in an over-voltage situation, the mechanical brake immediately cuts in.

### 4.5.2 Parallel Connection of Motors

The frequency converter can control several parallel-connected motors. The total current consumption of the motors must not exceed the rated output current  $I_{M,N}$  for the frequency converter.

 **NB!**  
Installations with cables connected in a common joint as in the illustration below, is only recommended for short cable lengths.

 **NB!**  
When motors are connected in parallel, par. 1-29 *Automatic Motor Adaptation (AMA)* cannot be used.

 **NB!**  
The electronic thermal relay (ETR) of the frequency converter cannot be used as motor protection for the individual motor in systems with parallel-connected motors. Provide further motor protection by e.g. thermistors in each motor or individual thermal relays (circuit breakers are not suitable as protection).

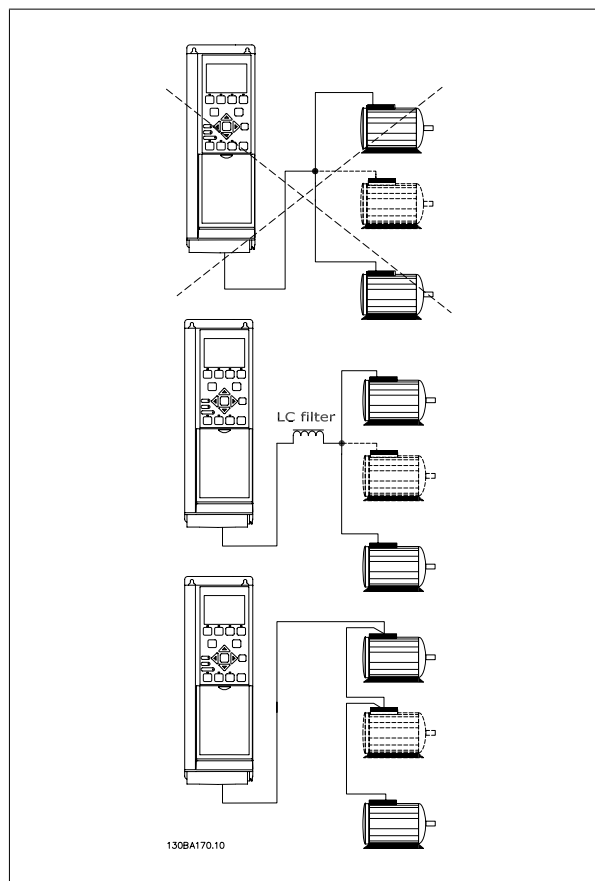

Problems may arise at start and at low RPM values if motor sizes are widely different because small motors' relatively high ohmic resistance in the stator calls for a higher voltage at start and at low RPM values.

### 4.5.3 Motor Thermal Protection

The electronic thermal relay in the frequency converter has received UL-approval for single motor protection, when par. 1-90 *Motor Thermal Protection* is set for *ETR Trip* and par. 1-24 *Motor Current* is set to the rated motor current (see motor name plate).

For thermal motor protection it is also possible to use the MCB 112 PTC Thermistor Card option. This card provides ATEX certificate to protect motors in explosion hazardous areas, Zone 1/21 and Zone 2/22. Please refer to the *Design Guide* for further information.

5

## 5 How to Operate the Frequency Converter

### 5.1.1 Three ways of operating

The frequency converter can be operated in 3 ways:

1. Graphical Local Control Panel (GLCP), see 5.1.2
2. Numeric Local Control Panel (NLCP), see 5.1.3
3. RS-485 serial communication or USB, both for PC connection, see 5.1.4

If the frequency converter is fitted with fieldbus option, please refer to relevant documentation.

### 5.1.2 How to operate graphical LCP (GLCP)

The following instructions are valid for the GLCP (LCP 102).

The GLCP is divided into four functional groups:

1. Graphical display with Status lines.
2. Menu keys and indicator lights (LED's) - selecting mode, changing parameters and switching between display functions.
3. Navigation keys and indicator lights (LEDs).
4. Operation keys and indicator lights (LEDs).

#### Graphical display:

The LCD-display is back-lit with a total of 6 alpha-numeric lines. All data is displayed on the LCP which can show up to five operating variables while in [Status] mode.

#### Display lines:

- a. **Status line:** Status messages displaying icons and graphics.
- b. **Line 1-2:** Operator data lines displaying data and variables defined or chosen by the user. By pressing the [Status] key, up to one extra line can be added.
- c. **Status line:** Status messages displaying text.

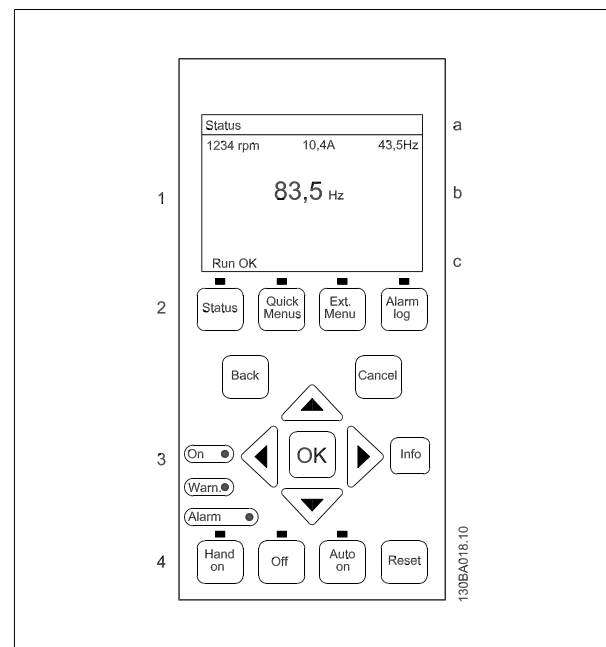

The display is divided into 3 sections:

**Top section** (a) shows the status when in status mode or up to 2 variables when not in status mode and in the case of Alarm/Warning.

The number of the Active Set-up (selected as the Active Set-up in par. 0-10 *Active Set-up*) is shown. When programming in another Set-up than the Active Set-up, the number of the Set-up being programmed appears to the right in brackets.

The **Middle section** (b) shows up to 5 variables with related unit, regardless of status. In case of alarm/warning, the warning is shown instead of the variables.

The **Bottom section** (c) always shows the state of the frequency converter in Status mode.

It is possible to toggle between three status read-out displays by pressing the [Status] key. Operating variables with different formatting are shown in each status screen - see below.

5

Several values or measurements can be linked to each of the displayed operating variables. The values / measurements to be displayed can be defined via par. 0-20 *Display Line 1.1 Small*, par. 0-21 *Display Line 1.2 Small*, par. 0-22 *Display Line 1.3 Small*, par. 0-23 *Display Line 2 Large* and par. 0-24 *Display Line 3 Large*, which can be accessed via [QUICK MENU], "Q3 Function Setups", "Q3-1 General Settings", "Q3-13 Display Settings".

Each value / measurement readout parameter selected in par. 0-20 *Display Line 1.1 Small* to par. 0-24 *Display Line 3 Large* has its own scale and number of digits after a possible decimal point. Larger numeric values are displayed with few digits after the decimal point.

Ex.: Current readout  
5.25 A; 15.2 A 105 A.

**Status display I:**

This read-out state is standard after start-up or initialization. Use [INFO] to obtain information about the value/measurement linked to the displayed operating variables (1.1, 1.2, 1.3, 2, and 3). See the operating variables shown in the display in this illustration. 1.1, 1.2 and 1.3 are shown in small size. 2 and 3 are shown in medium size.

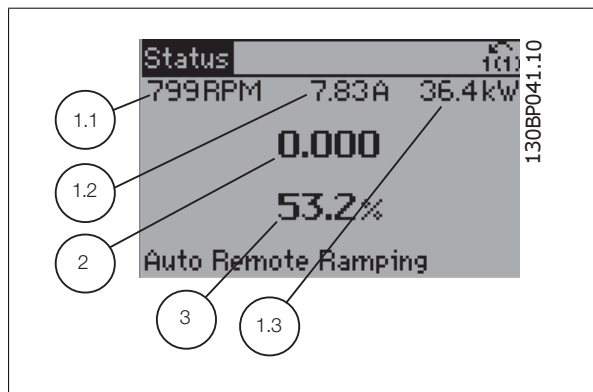

**Status display II:**

See the operating variables (1.1, 1.2, 1.3, and 2) shown in the display in this illustration. In the example, Speed, Motor current, Motor power and Frequency are selected as variables in the first and second lines. 1.1, 1.2 and 1.3 are shown in small size. 2 is shown in large size.

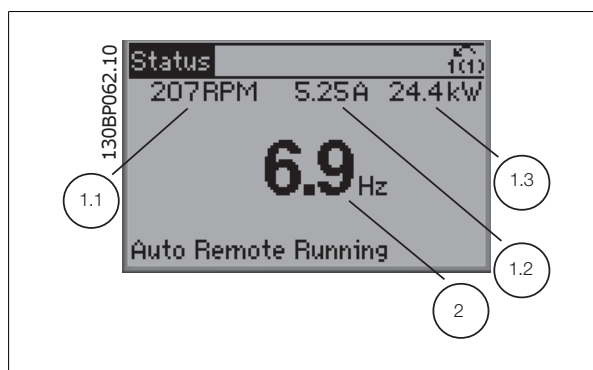

**Status display III:**

This state displays the event and action of the Smart Logic Control. For further information, see section *Smart Logic Control*.

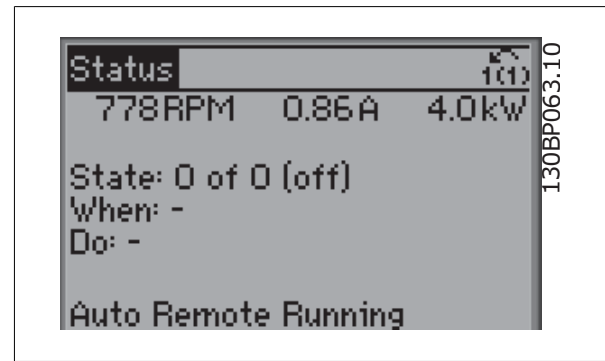

**Display Contrast Adjustment**

Press [status] and [▲] for darker display

Press [status] and [▼] for brighter display

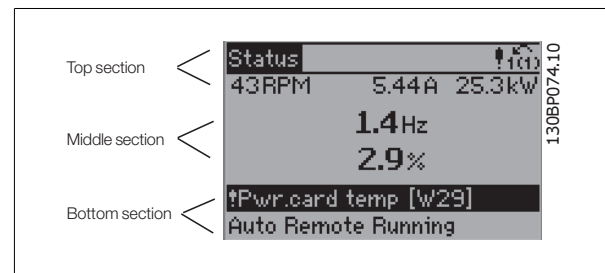

**Indicator lights (LEDs):**

If certain threshold values are exceeded, the alarm and/or warning LED lights up. A status and alarm text appear on the control panel. The On LED is activated when the frequency converter receives power from mains voltage, a DC bus terminal, or an external 24 V supply. At the same time, the back light is on.

- Green LED/On: Control section is working.
- Yellow LED/Warn.: Indicates a warning.
- Flashing Red LED/Alarm: Indicates an alarm.



## GLCP keys

### Menu keys

The menu keys are divided into functions. The keys below the display and indicator lamps are used for parameter set-up, including choice of display indication during normal operation.



### [Status]

indicates the status of the frequency converter and/or the motor. 3 different readouts can be chosen by pressing the [Status] key:

5 line readouts, 4 line readouts or Smart Logic Control.

Use [Status] for selecting the mode of display or for changing back to Display mode from either the Quick Menu mode, the Main Menu mode or Alarm mode. Also use the [Status] key to toggle single or double read-out mode.

### [Quick Menu]

allows quick set-up of the frequency converter. **The most common IVS 102 functions can be programmed here.**

The [Quick Menu] consists of:

- My Personal Menu
- Quick Set-up
- Function Set-up
- Changes Made
- Loggings

The Function set-up provides quick and easy access to all parameters required for the majority of IVS 102 applications including most VAV and CAV supply and return fans, cooling tower fans, Primary, Secondary and Condenser Water Pumps and other pump, fan and compressor applications. Amongst other features it also includes parameters for selecting which variables to display on the LCP, digital preset speeds, scaling of analog references, closed loop single zone and multi-zone applications and specific functions related to Fans, Pumps and Compressors.

The Quick Menu parameters can be accessed immediately unless a password has been created via par. 0-60 *Main Menu Password*, par. 0-61 *Access to Main Menu w/o Password*, par. 0-65 *Personal Menu Password* or par. 0-66 *Access to Personal Menu w/o Password*.

It is possible to switch directly between Quick Menu mode and Main Menu mode.

### [Main Menu]

is used for programming all parameters. The Main Menu parameters can be accessed immediately unless a password has been created via par. 0-60 *Main Menu Password*, par. 0-61 *Access to Main Menu w/o Password*, par. 0-65 *Personal Menu Password* or par. 0-66 *Access to Personal Menu w/o Password*. For the majority of IVS 102 applications it is not necessary to access the Main Menu parameters but instead the Quick Menu, Quick Set-up and Function Set-up provides the simplest and quickest access to the typical required parameters.

It is possible to switch directly between Main Menu mode and Quick Menu mode.

Parameter shortcut can be carried out by pressing down the [Main Menu] key for 3 seconds. The parameter shortcut allows direct access to any parameter.

### [Alarm Log]

displays an Alarm list of the five latest alarms (numbered A1-A5). To obtain additional details about an alarm, use the arrow keys to manoeuvre to the alarm number and press [OK]. Information is displayed about the condition of the frequency converter before it enters the alarm mode.

The Alarm log button on the LCP allows access to both Alarm log and Maintenance log.

### [Back]

reverts to the previous step or layer in the navigation structure.

### [Cancel]

last change or command will be cancelled as long as the display has not been changed.

### [Info]

displays information about a command, parameter, or function in any display window. [Info] provides detailed information when needed. Exit Info mode by pressing either [Info], [Back], or [Cancel].



**Navigation Keys**

The four navigation arrows are used to navigate between the different choices available in [Quick Menu], [Main Menu] and [Alarm Log]. Use the keys to move the cursor.

[OK] is used for choosing a parameter marked by the cursor and for enabling the change of a parameter.

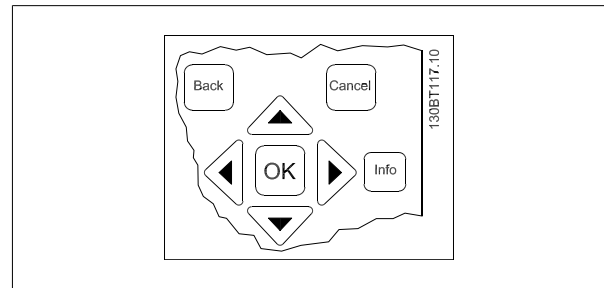

**Operation Keys** for local control are found at the bottom of the control panel.



**[Hand On]**

enables control of the frequency converter via the GLCP. [Hand On] also starts the motor, and it is now possible to enter the motor speed data by means of the arrow keys. The key can be selected as *Enable* [1] or *Disable* [0] via par. 0-40 [Hand on] Key on LCP.

The following control signals will still be active when [Hand On] is activated:

- [Hand On] - [Off] - [Auto on]
- Reset
- Coasting stop inverse
- Reversing
- Set-up select lsb - Set-up select msb
- Stop command from serial communication
- Quick stop
- DC brake

**NB!**  
External stop signals activated by means of control signals or a serial bus will override a "start" command via the LCP.

**[Off]**

stops the connected motor. The key can be selected as *Enable* [1] or *Disable* [0] via par. 0-41 [Off] Key on LCP. If no external stop function is selected and the [Off] key is inactive the motor can only be stopped by disconnecting the mains supply.

**[Auto on]**

enables the frequency converter to be controlled via the control terminals and/or serial communication. When a start signal is applied on the control terminals and/or the bus, the frequency converter will start. The key can be selected as Enable [1] or Disable [0] via par. 0-43 *[Auto on] Key on LCP*.

**NB!**  
An active HAND-OFF-AUTO signal via the digital inputs has higher priority than the control keys [Hand on] – [Auto on].

**[Reset]**

is used for resetting the frequency converter after an alarm (trip). It can be selected as *Enable* [1] or *Disable* [0] via par. 0-43 *[Reset] Key on LCP*.

The parameter shortcut can be carried out by holding down the [Main Menu] key for 3 seconds. The parameter shortcut allows direct access to any parameter.

5

**5.1.3 RS-485 bus connection**

One or more frequency converters can be connected to a controller (or master) using the RS-485 standard interface. Terminal 68 is connected to the P signal (TX+, RX+), while terminal 69 is connected to the N signal (TX-,RX-).

If more than one frequency converter is connected to a master, use parallel connections.

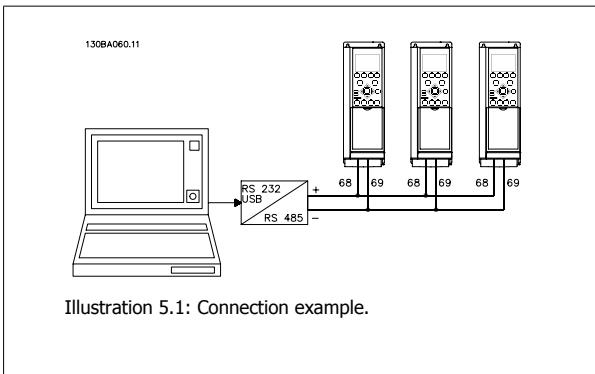

In order to avoid potential equalizing currents in the screen, earth the cable screen via terminal 61, which is connected to the frame via an RC-link.

**Bus termination**

The RS-485 bus must be terminated by a resistor network at both ends. If the drive is the first or the last device in the RS-485 loop, set the switch S801 on the control card for ON.

For more information, see the paragraph *Switches S201, S202, and S801*.

**5.1.4 How to connect a PC to the frequency converter**

To control or program the frequency converter from a PC, install the PC-based Configuration Tool MCT 10.

The PC is connected via a standard (host/device) USB cable, or via the RS-485 interface as shown in the IVS 102 *Design Guide, chapter How to Install > Installation of misc. connections*.

**NB!**  
The USB connection is galvanically isolated from the supply voltage (PELV) and other high-voltage terminals. The USB connection is connected to protection earth on the frequency converter. Use only an isolated laptop as PC connection to the USB connector on the frequency converter.



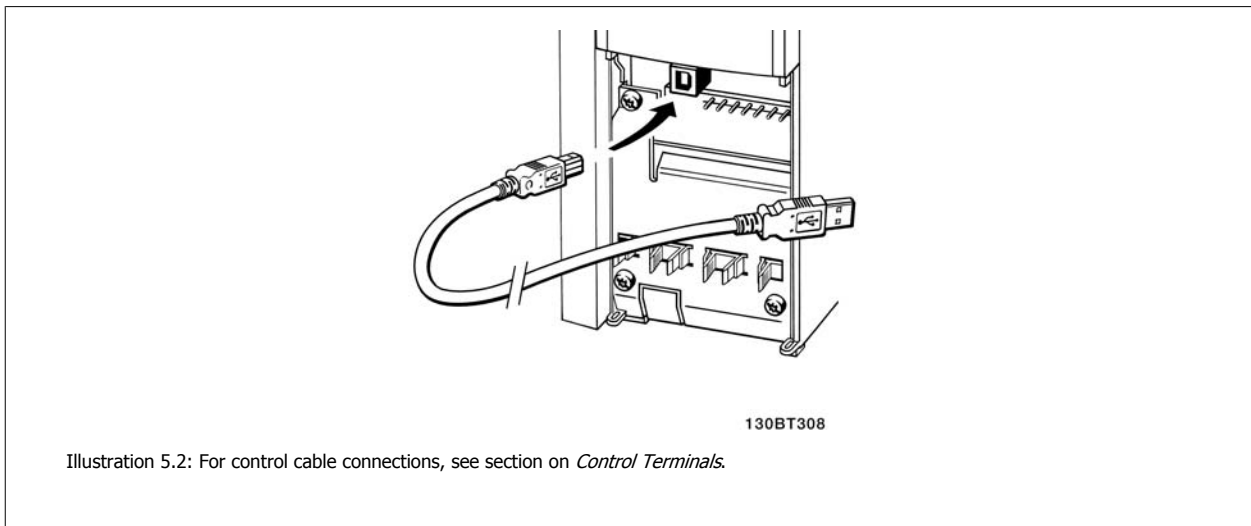

### 5.1.5 PC software tools

#### PC-based Configuration Tool MCT 10

All Frequency converters are equipped with a serial communication port. Armstrong provides a PC tool for communication between PC and frequency converter, PC-based Configuration Tool MCT 10. Please check the section on *Available Literature* for detailed information on this tool.

#### MCT 10 set-up software

MCT 10 has been designed as an easy to use interactive tool for setting parameters in our frequency converters. .

The MCT 10 set-up software will be useful for:

- Planning a communication network off-line. MCT 10 contains a complete frequency converter database
- Commissioning frequency converters on line
- Saving settings for all frequency converters
- Replacing a frequency converter in a network
- Simple and accurate documentation of frequency converter settings after commissioning.
- Expanding an existing network
- Future developed frequency converters will be supported

MCT 10 set-up software supports Profibus DP-V1 via a Master class 2 connection. It makes it possible to on line read/write parameters in a frequency converter via the Profibus network. This will eliminate the need for an extra communication network.

#### Save frequency converter settings:

1. Connect a PC to the unit via USB com port. (Note: Use a PC, which is isolated from the mains, in conjunction with the USB port. Failure to do so may damage equipment.)
2. Open MCT 10 Set-up Software
3. Choose "Read from drive"
4. Choose "Save as"

All parameters are now stored in the PC.

5

**Load frequency converter settings:**

1. Connect a PC to the frequency converter via USB com port
2. Open MCT 10 Set-up software
3. Choose "Open"– stored files will be shown
4. Open the appropriate file
5. Choose "Write to drive"

All parameter settings are now transferred to the frequency converter.

A separate manual for MCT 10 Set-up Software is available: *MG.10.Rx.yy*.

**The MCT 10 Set-up software modules**

The following modules are included in the software package:

	<p><b>MCT Set-up 10 Software</b>                  Setting parameters                  Copy to and from frequency converters                  Documentation and print out of parameter settings incl. diagrams</p>
	<p><b>Ext. user interface</b>                  Preventive Maintenance Schedule                  Clock settings                  Timed Action Programming                  Smart Logic Controller Set-up</p>

**Ordering number:**

Please order the CD containing MCT 10 Set-up Software using code number 130B1000.

**5.1.6 Tips and tricks**

*	For the majority of HVAC applications the Quick Menu, Quick Set-up and Function Set-up provides the simplest and quickest access to all the typical parameters required.
*	Whenever possible, performing an AMA, will ensure best shaft performance
*	Contrast of the display can be adjusted by pressing [Status] and [▲] for darker display or by pressing [Status] and [▼] for brighter display
*	Under [Quick Menu] and [Changes Made] all parameters that have been changed from factory settings are displayed
*	Press and hold [Main Menu] key for 3 seconds for access to any parameter
*	For service purposes it is recommended to copy all parameters to the LCP, see par. 0-50 <i>LCP Copy</i> for further information

Table 5.1: Tips and tricks

**5.1.7 Quick transfer of parameter settings when using GLCP**

Once the set-up of a frequency converter is complete, it is recommended to store (backup) the parameter settings in the GLCP or on a PC via MCT 10 Set-up Software Tool.



Stop the motor before performing any of these operations.

**Data storage in LCP:**

1. Go to par. 0-50 *LCP Copy*
2. Press the [OK] key
3. Select "All to LCP"
4. Press the [OK] key

All parameter settings are now stored in the GLCP indicated by the progress bar. When 100% is reached, press [OK].

The GLCP can now be connected to another frequency converter and the parameter settings copied to this frequency converter.

**Data transfer from LCP to Frequency converter:**

1. Go to par. 0-50 *LCP Copy*
2. Press the [OK] key
3. Select "All from LCP"
4. Press the [OK] key

The parameter settings stored in the GLCP are now transferred to the frequency converter indicated by the progress bar. When 100% is reached, press [OK].

### 5.1.8 Initialisation to default settings

There are two ways to initialise the frequency converter to default: Recommended initialisation and manual initialisation. Please be aware that they have different impact according to the below description.

**Recommended initialisation (via par. 14-22 *Operation Mode*)**

1. Select par. 14-22 *Operation Mode*
2. Press [OK]
3. Select "Initialisation" (for NLCP select "2")
4. Press [OK]
5. Remove power to unit and wait for display to turn off.
6. Reconnect power and the frequency converter is reset. Note that first start-up takes a few more seconds
7. Press [Reset]

<p>Par. 14-22 <i>Operation Mode</i> initialises all except:</p> <p>Par. 14-50 <i>RFI Filter</i></p> <p>Par. 8-30 <i>Protocol</i></p> <p>Par. 8-31 <i>Address</i></p> <p>Par. 8-32 <i>Baud Rate</i></p> <p>Par. 8-35 <i>Minimum Response Delay</i></p> <p>Par. 8-36 <i>Max Response Delay</i></p> <p>Par. 8-37 <i>Maximum Inter-Char Delay</i></p> <p>Par. 15-00 <i>Operating Hours</i> to par. 15-05 <i>Over Volt's</i></p> <p>Par. 15-20 <i>Historic Log: Event</i> to par. 15-22 <i>Historic Log: Time</i></p> <p>Par. 15-30 <i>Alarm Log: Error Code</i> to par. 15-32 <i>Alarm Log: Time</i></p>
--

**NB!**  
Parameters selected in par. 0-25 *My Personal Menu*, will stay present, with default factory setting.

**Manual initialisation**

**NB!**  
When carrying out manual initialisation, serial communication, RFI filter settings and fault log settings are reset. Removes parameters selected in par. 0-25 *My Personal Menu*.

1. Disconnect from mains and wait until the display turns off.
- 2a. Press [Status] - [Main Menu] - [OK] at the same time while power up for Graphical LCP (GLCP)
- 2b. Press [Menu] while power up for LCP 101, Numerical Display
3. Release the keys after 5 s
4. The frequency converter is now programmed according to default settings

This parameter initialises all except:

Par. 15-00 *Operating Hours*

Par. 15-03 *Power Up's*

Par. 15-04 *Over Temp's*

Par. 15-05 *Over Volt's*

## 6 How to Programme

### 6.1.1 Parameter Set-Up

Group	Title	Function
0-	Operation and Display	Parameters used to program the fundamental functions of the frequency converter and the LCP including: selection of language; selection of which variables are displayed at each position in the display (e.g. static duct pressure or condenser water return temperature can be displayed with the setpoint in small digits in the top row and feedback in large digits in the centre of the display); enabling/disabling of the LCP keys/buttons; passwords for the LCP; upload and download of commissioned parameters to/from the LCP and setting the built in clock.
1-	Load / Motor	Parameters used to configure the frequency converter for the specific application and motor including: open or closed loop operation; type of application such as compressor, fan or centrifugal pump; motor nameplate data; auto-tuning of the drive to the motor for optimum performance; flying start (typically used for fan applications) and motor thermal protection.
2-	Brakes	Parameters used to configure braking functions of the frequency converter which although not common in many HVAC applications, can be useful on special fan applications. Parameters including: DC braking; dynamic/resistor braking and over voltage control (which provides automatic adjustment of the deceleration rate (auto-ramping) to avoid tripping when decelerating large inertia fans)
3-	Reference / Ramps	Parameters used to program the minimum and maximum reference limits of speed (RPM/Hz) in open loop or in actual units when operating in closed loop); digital/preset references; jog speed; definition of the source of each reference (e.g. which analog input the reference signal is connected to); ramp up and down times and digital potentiometer settings.
4-	Limits / Warnings	Parameters used to program limits and warnings of operation including: allowable motor direction; minimum and maximum motor speeds (e.g. in pump applications it is typical to program a minimum speed to approx 30-40% to ensure pump seals are adequately lubricated at all times, avoid cavitation and ensure adequate head is produced at all times to create flow); torque and current limits to protect the pump, fan or compressor driven by the motor; warnings for low/high current, speed, reference, and feedback; missing motor phase protection; speed bypass frequencies including semi-automatic setup of these frequencies (e.g. to avoid resonance conditions on cooling tower and other fans).
5-	Digital In / Out	Parameters used to program the functions of all digital inputs, digital outputs, relay outputs, pulse inputs and pulse outputs for terminals on the control card and all option cards.
6-	Analog In / Out	Parameters used to program the functions associated with all analog inputs and analog outputs for the terminals on the control card and General Purpose I/O option (MCB101) (note: NOT Analog I/O option MCB109, see parameter group 26-00) including: analog input live zero timeout function (which for example can be used to command a cooling tower fan to operate at full speed if the condenser water return sensor fails); scaling of the analog input signals (for example to match the analog input to the mA and pressure range of a static duct pressure sensor); filter time constant to filter out electrical noise on the analog signal which can sometimes occur when long cables are installed; function and scaling of the analog outputs (for example to provide an analog output representing motor current or kW to an analog input of a DDC controller) and to configure the analog outputs to be controlled by the BMS via a high level interface (HLI) (e.g. to control a chilled water valve) including ability to define a default value of these outputs in the event of the HLI failing.
8-	Communication and Options	Parameters used for configuring and monitoring functions associated with the serial communications / high level interface to the frequency converter
9-	Profibus	Parameters only applicable when a Profibus option is installed.
10-	CAN Fieldbus	Parameters only applicable when a DeviceNet option is installed.
11-	LonWorks	Parameters only applicable when a Lonworks option is installed.

Table 6.1: Parameter Groups

Group	Title	Function
13-	Smart Logic Controller	Parameters used to configure the built in Smart Logic Controller (SLC) which can be used for simple functions such as comparators (e.g. if running above xHz, activate output relay), timers (e.g. when a start signal is applied, first activate output relay to open supply air damper and wait x seconds before ramping up) or a more complex sequence of user defined actions executed by the SLC when the associated user defined event is evaluated as TRUE by the SLC. (For example, initiate an economiser mode in a simple AHU cooling application control scheme where there is no BMS. For such an application the SLC can monitor the outside air relative humidity and if it is below a defined value, the supply air temperature setpoint could be automatically increased. With the frequency converter monitoring the outside air relative humidity and supply air temperature via it's analog inputs and controlling the chilled water valve via one of the extended PI(D) loops and an analog output, it would then modulate that valve to maintain a higher supply air temperature). The SLC can often replace the need for other external control equipment.
14-	Special Functions	Parameters used to configure special functions of the frequency converter including: setting of the switching frequency to reduce audible noise from the motor (sometimes required for fan applications); kinetic back-up function (especially useful for critical applications in semi-conductor installations where performance under mains dip/mains loss is important); mains imbalance protection; automatic reset (to avoid the need for a manual reset of Alarms); energy optimisation parameters (which typically do not need changing but enable fine tuning of this automatic function (if necessary) ensuring the frequency converter and motor combination operate at their optimum efficiency at full and partial load conditions) and auto-derating functions (which enable the frequency converter to continue operation at reduced performance under extreme operating conditions ensuring maximum up time).
15-	FC Information	Parameters providing operating data and other drive information including: operating and running hour counters; kWh counter; resetting of the running and kWh counters; alarm/fault log (where the past 10 alarms are logged along with any associated value and time) and drive and option card identification parameters such as code number and software version.
16-	Data Readouts	Read only parameters which display the status/value of many operating variables which can be displayed on the LCP or viewed in this parameter group. These parameters can be particularly useful during commissioning when interfacing with a BMS via a high level interface.
18-	Info & Readouts	Read only parameters which display the last 10 preventative maintenance log items, actions and time and the value of analog inputs and outputs on the Analog I/O option card which can be particularly useful during commissioning when interfacing with a BMS via a high level interface.
20-	FC Closed Loop	Parameters used to configure the closed loop PI(D) controller which controls the speed of the pump, fan or compressor in closed loop mode including: defining where each of the 3 possible feedback signals come from (e.g. which analog input or the BMS HLI); conversion factor for each of the feedback signals (e.g. where a pressure signal is used for indication of flow in an AHU or converting from pressure to temperature in a compressor application); engineering unit for the reference and feedback (e.g. Pa, kPa, m Wg, in Wg, bar, m3/s, m3/h, °C, °F etc); the function (e.g. sum, difference, average, minimum or maximum) used to calculate the resulting feedback for single zone applications or the control philosophy for multi-zone applications; programming of the setpoint(s) and manual or auto-tuning of the PI(D) loop.
21-	Extended Closed Loop	Parameters used to configure the 3 extended closed loop PI(D) controllers which for example can be used to control external actuators (e.g. chilled water valve to maintain supply air temperature in a VAV system) including: engineering unit for the reference and feedback of each controller (e.g. °C, °F etc); defining the range of the reference/setpoint for each controller; defining where each of the references/setpoints and feedback signals come from (e.g. which analog input or the BMS HLI); programming of the setpoint and manual or auto-tuning of the each of the PI(D) controllers.
22-	Application Functions	Parameters used to monitor, protect and control pumps, fans and compressors including: no flow detection and protection of pumps (including auto-setup of this function); dry pump protection; end of curve detection and protection of pumps; sleep mode (especially useful for cooling tower and booster pump sets); broken belt detection (typically used for fan applications to detect no air flow instead of using a $\Delta p$ switch installed across the fan); short cycle protection of compressors and pump flow compensation of setpoint (especially useful for secondary chilled water pump applications where the $\Delta p$ sensor has been installed close to the pump and not across the furthest most significant load(s) in the system; using this function can compensate for the sensor installation and help to realise the maximum energy savings).

Parameter descriptions and selections are displayed on the graphic (GLCP) or numeric (NLCP) display. (See relevant section for details.) Access the parameters by pressing the [Quick Menu] or [Main Menu] button on the control panel. The Quick Menu is used primarily for commissioning the unit at start-up by providing the parameters necessary to start operation. The Main Menu provides access to all parameters for detailed application programming.

All digital input/output and analog input/output terminals are multifunctional. All terminals have factory default functions suitable for the majority of HVAC applications but if other special functions are required, they must be programmed as explained in parameter group 5 or 6.

### 6.1.2 Quick Menu mode

#### Parameter data

The graphical display (GLCP) provides access to all parameters listed under the Quick Menus. The numeric display (NLCP) only provides access to the Quick Setup parameters. To set parameters using the [Quick Menu] button - enter or change parameter data or settings in accordance with the following procedure:

1. Press Quick Menu button
2. Use the [▲] and [▼] buttons to find the parameter you want to change
3. Press [OK]
4. Use [▲] and [▼] buttons to select the correct parameter setting
5. Press [OK]
6. To move to a different digit within a parameter setting, use the [◀] and [▶] buttons
7. Highlighted area indicates digit selected for change
8. Press [Cancel] button to disregard change, or press [OK] to accept change and enter the new setting

#### Example of changing parameter data

Assume parameter 22-60 is set to [Off]. However, you want to monitor the fan-belt condition - non- broken or broken - according to the following procedure:

1. Press Quick Menu key
2. Choose Function Setups with the [▼] button
3. Press [OK]
4. Choose Application Settings with the [▼] button
5. Press [OK]
6. Press [OK] again for Fan Functions
7. Choose Broken Belt Function by pressing [OK]
8. With [▼] button, choose [2] Trip

The frequency converter will now trip if a broken fan-belt is detected.

#### Select [My Personal Menu] to display personal parameters:

Select [My Personal Menu] to display only the parameters, which have been pre-selected and programmed as personal parameters. For example, an AHU or pump OEM may have pre-programmed personal parameters to be in My Personal Menu during factory commissioning to make on-site commissioning/ fine tuning simpler. These parameters are selected in par. 0-25 *My Personal Menu*. Up to 20 different parameters can be programmed in this menu.

#### Select [Changes Made] to get information about:

- The last 10 changes. Use the up/down navigation keys to scroll between the last 10 changed parameters.
- The changes made since default setting.

#### Select [Loggings]:

to get information about the display line read-outs. The information is shown as graphs.

Only display parameters selected in par. 0-20 *Display Line 1.1 Small* and par. 0-24 *Display Line 3 Large* can be viewed. It is possible to store up to 120 samples in the memory for later reference.

**Efficient Parameter Set-up for IVS 102 Applications:**

The parameters can easily be set up for the vast majority of the IVS 102 applications only by using the [Quick Setup] option.

After pressing [Quick Menu], the different choices in the Quick Menu are listed. See also illustration 6.1 below and tables Q3-1 to Q3-4 in the following *Function Setups* section.

**Example of using the Quick Setup option:**

Assume you want to set the Ramp Down Time to 100 seconds!

1. Select [Quick Setup]. The first par.0-01 *Language* in Quick Setup appears
2. Press [▼] repeatedly until par.3-42 *Ramp 1 Ramp Down Time* appears with the default setting of 20 seconds
3. Press [OK]
4. Use the [◀] button to highlight the 3rd digit before the comma
5. Change '0' to '1' by using the [▲] button
6. Use the [▶] button to highlight the digit '2'
7. Change '2' to '0' with the [▼] button
8. Press [OK]

The new ramp-down time is now set to 100 seconds.  
It is recommended to do the set-up in the order listed.

6



**NB!**  
A complete description of the function is found in the parameter sections of this manual.



130BP064.11

Illustration 6.1: Quick Menu view.

The Quick Setup menu gives access to the 18 most important setup parameters of the frequency converter. After programming the frequency converter will, in most cases, be ready for operation. The 18 Quick Setup parameters are shown in the table below. A complete description of the function is given in the parameter description sections of this manual.



Parameter	[Units]
Par.0-01 <i>Language</i>	
Par.1-20 <i>Motor Power [kW]</i>	[kW]
Par.1-21 <i>Motor Power [HP]</i>	[HP]
Par.1-22 <i>Motor Voltage*</i>	[V]
Par.1-23 <i>Motor Frequency</i>	[Hz]
Par.1-24 <i>Motor Current</i>	[A]
Par.1-25 <i>Motor Nominal Speed</i>	[RPM]
Par.1-28 <i>Motor Rotation Check</i>	[Hz]
Par.3-41 <i>Ramp 1 Ramp Up Time</i>	[s]
Par.3-42 <i>Ramp 1 Ramp Down Time</i>	[s]
Par.4-11 <i>Motor Speed Low Limit [RPM]</i>	[RPM]
Par.4-12 <i>Motor Speed Low Limit [Hz]*</i>	[Hz]
Par.4-13 <i>Motor Speed High Limit [RPM]</i>	[RPM]
Par.4-14 <i>Motor Speed High Limit [Hz]*</i>	[Hz]
Par. 3-19 <i>Jog Speed [RPM]</i>	[RPM]
Par.3-11 <i>Jog Speed [Hz]*</i>	[Hz]
Par. 5-12 <i>Terminal 27 Digital Input</i>	
Par.5-40 <i>Function Relay**</i>	

6

Table 6.2: Quick Setup parameters

\*The display showing depends on choices made in par. 0-02 *Motor Speed Unit* and par. 0-03 *Regional Settings*. The default settings of par. 0-02 *Motor Speed Unit* and par. 0-03 *Regional Settings* depend on which region of the world the frequency converter is supplied to but can be re-programmed as required.

\*\* Par.5-40 *Function Relay*, is an array, where one may choose between Relay1 [0] or Relay2 [1]. Standard setting is Relay1 [0] with the default choice Alarm [9].

See the parameter description in the section *Commonly Used Parameters*.

For a detailed information about settings and programming, please see the

x=version number

y=language

**NB!**  
 If [No Operation] is selected in par. 5-12 *Terminal 27 Digital Input*, no connection to +24 V on terminal 27 is necessary to enable start.  
 If [Coast Inverse] (factory default value) is selected in par. 5-12 *Terminal 27 Digital Input*, a connection to +24V is necessary to enable start.

## 0-01 Language

### Option:

### Function:

Defines the language to be used in the display. The frequency converter can be delivered with 4 different language packages. English and German are included in all packages. English cannot be erased or manipulated.

[0] *	English	Part of Language packages 1 - 4
[1]	Deutsch	Part of Language packages 1 - 4
[2]	Francais	Part of Language package 1
[3]	Dansk	Part of Language package 1
[4]	Spanish	Part of Language package 1
[5]	Italiano	Part of Language package 1
	Svenska	Part of Language package 1
[7]	Nederlands	Part of Language package 1
	Chinese	Part of Language package 2
	Suomi	Part of Language package 1
	English US	Part of Language package 4
	Greek	Part of Language package 4
	Bras.port	Part of Language package 4
	Slovenian	Part of Language package 3
	Korean	Part of Language package 2
	Japanese	Part of Language package 2
	Turkish	Part of Language package 4
	Trad.Chinese	Part of Language package 2
	Bulgarian	Part of Language package 3
	Srpski	Part of Language package 3
	Romanian	Part of Language package 3
	Magyar	Part of Language package 3
	Czech	Part of Language package 3
	Polski	Part of Language package 4
	Russian	Part of Language package 3
	Thai	Part of Language package 2
	Bahasa Indonesia	Part of Language package 2
[99]	Unknown	

## 1-20 Motor Power [kW]

### Range:

### Function:

Application [Application dependant]  
dependent\*

**1-21 Motor Power [HP]**

**Range:** **Function:**

Application [Application dependant]  
dependent\*

**1-22 Motor Voltage**

**Range:** **Function:**

Application [Application dependant]  
dependent\*

**1-23 Motor Frequency**

**Range:** **Function:**

Application [20 - 1000 Hz]  
dependent\*

Select the motor frequency value from the motor nameplate data. For 87 Hz operation with 230/400 V motors, set the nameplate data for 230 V/50 Hz. Adapt par.4-13 *Motor Speed High Limit [RPM]* and par.3-03 *Maximum Reference* to the 87 Hz application.



**NB!**

This parameter cannot be adjusted while the motor is running.

**1-24 Motor Current**

**Range:** **Function:**

Application [Application dependant]  
dependent\*



**NB!**

This parameter cannot be adjusted while the motor is running.

**1-25 Motor Nominal Speed**

**Range:** **Function:**

Application [100 - 60000 RPM]  
dependent\*

Enter the nominal motor speed value from the motor nameplate data. This data is used for calculating automatic motor compensations.



**NB!**

This parameter cannot be changed while the motor is running.

**1-28 Motor Rotation Check**

**Option:**

**Function:**

Following installation and connection of the motor, this function allows the correct motor rotation direction to be verified. Enabling this function overrides any bus commands or digital inputs, except External Interlock and Safe Stop (if included).

[0] \* Off

Motor Rotation Check is not active.

[1] Enabled

Motor Rotation Check is enabled. Once enabled, Display shows:  
"Note! Motor may run in wrong direction".

Pressing [OK], [Back] or [Cancel] will dismiss the message and display a new message: "Press [Hand on] to start the motor. Press [Cancel] to abort". Pressing [Hand on] starts the motor at 5 Hz in forward direction and the display shows: "Motor is running. Check if motor rotation direction is correct. Press [Off] to stop the motor". Pressing [Off] stops the motor and resets par.1-28 *Motor Rotation Check*. If motor rotation direction is incorrect, two motor phase cables should be interchanged. **IMPORTANT:**

6



Mains power must be removed before disconnecting motor phase cables.

**3-41 Ramp 1 Ramp Up Time**

**Range:**

**Function:**

Application [Application dependant]  
dependent\*

**3-42 Ramp 1 Ramp Down Time**

**Range:**

**Function:**

Application [Application dependant]  
dependent\*

**4-14 Motor Speed High Limit [Hz]**

**Range:**

**Function:**

Application [Application dependant]  
dependent\*



**NB!**

Max. output frequency cannot exceed 10% of the inverter switching frequency (par.14-01 *Switching Frequency*).

**4-12 Motor Speed Low Limit [Hz]**

**Range:**

**Function:**

Application [Application dependant]  
dependent\*

**4-13 Motor Speed High Limit [RPM]**

**Range:**

**Function:**

Application [Application dependant]  
dependent\*



**NB!**

Max. output frequency cannot exceed 10% of the inverter switching frequency (par.14-01 *Switching Frequency*).



**NB!**

Any changes in par.4-13 *Motor Speed High Limit [RPM]* will reset the value in par.4-53 *Warning Speed High* to the same value as set in par.4-13 *Motor Speed High Limit [RPM]*.

**4-11 Motor Speed Low Limit [RPM]**

**Range:** Application [Application dependant]  
dependent\*

**Function:**

**3-11 Jog Speed [Hz]**

**Range:** Application [Application dependant]  
dependent\*

**Function:**

**6.1.3 Function Setups**

The Function set-up provides quick and easy access to all parameters required for the majority of IVS 102 applications including most VAV and CAV supply and return fans, cooling tower fans, Primary, Secondary and Condenser Water Pumps and other pump, fan and compressor applications.

How to access Function set-up - example

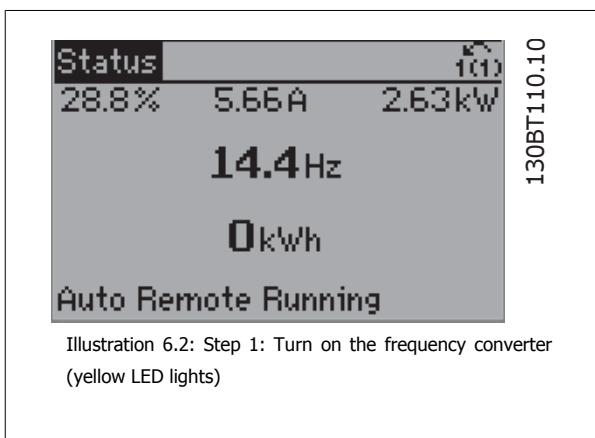

Illustration 6.2: Step 1: Turn on the frequency converter (yellow LED lights)

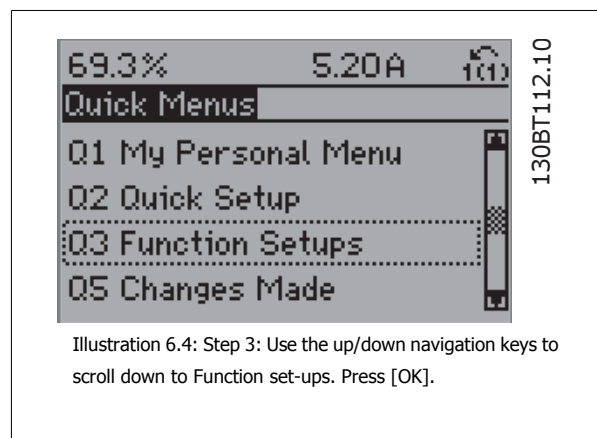

Illustration 6.4: Step 3: Use the up/down navigation keys to scroll down to Function set-ups. Press [OK].

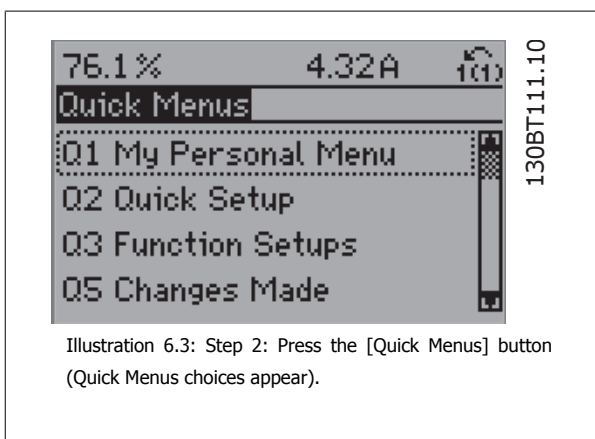

Illustration 6.3: Step 2: Press the [Quick Menu] button (Quick Menu choices appear).

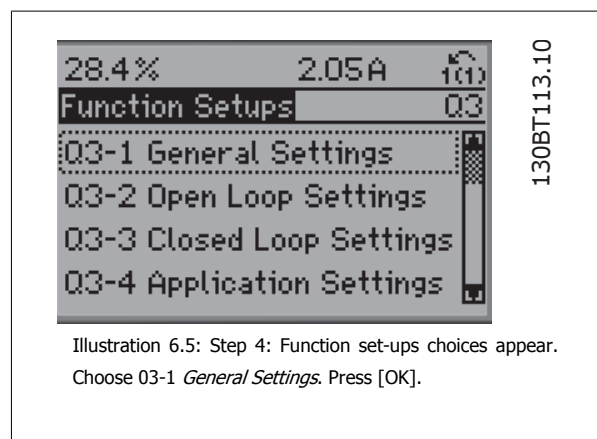

Illustration 6.5: Step 4: Function set-ups choices appear. Choose 03-1 *General Settings*. Press [OK].

6

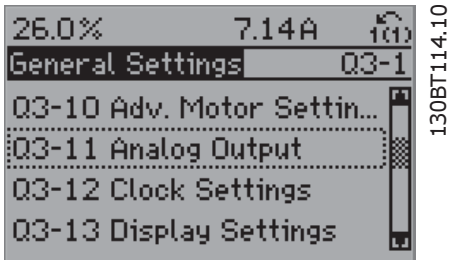

Illustration 6.6: Step 5: Use the up/down navigation keys to scroll down to i.e. 03-11 *Analog Outputs*. Press [OK].

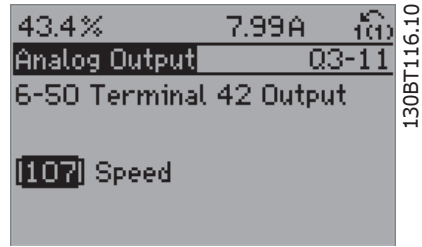

Illustration 6.8: Step 7: Use the up/down navigation keys to select between the different choices. Press [OK].

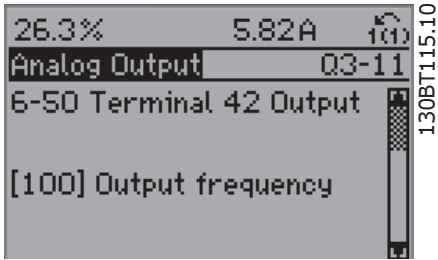

Illustration 6.7: Step 6: Choose par. 6-50. Press [OK].

**Function Set-ups parameters**

The Function Setups parameters are grouped in the following way:

Q3-1 General Settings			
Q3-10 Adv. Motor Settings	Q3-11 Analog Output	Q3-12 Clock Settings	Q3-13 Display Settings
Par.1-90 <i>Motor Thermal Protection</i>	Par.6-50 <i>Terminal 42 Output</i>	Par.0-70 <i>Date and Time</i>	Par. 0-20 <i>Display Line 1.1 Small</i>
Par.1-93 <i>Thermistor Source</i>	Par.6-51 <i>Terminal 42 Output Min Scale</i>	Par.0-71 <i>Date Format</i>	Par. 0-21 <i>Display Line 1.2 Small</i>
Par.1-29 <i>Automatic Motor Adaptation (AMA)</i>	Par.6-52 <i>Terminal 42 Output Max Scale</i>	Par.0-72 <i>Time Format</i>	Par. 0-22 <i>Display Line 1.3 Small</i>
Par.14-01 <i>Switching Frequency</i>		Par.0-74 <i>DST/Summertime</i>	Par. 0-23 <i>Display Line 2 Large</i>
Par.4-53 <i>Warning Speed High</i>		Par.0-76 <i>DST/Summertime Start</i>	Par. 0-24 <i>Display Line 3 Large</i>
		Par.0-77 <i>DST/Summertime End</i>	Par.0-37 <i>Display Text 1</i>
			Par.0-38 <i>Display Text 2</i>
			Par.0-39 <i>Display Text 3</i>

Q3-2 Open Loop Settings	
Q3-20 Digital Reference	Q3-21 Analog Reference
Par.3-02 <i>Minimum Reference</i>	Par.3-02 <i>Minimum Reference</i>
Par.3-03 <i>Maximum Reference</i>	Par.3-03 <i>Maximum Reference</i>
Par.3-10 <i>Preset Reference</i>	Par.6-10 <i>Terminal 53 Low Voltage</i>
Par. 5-13 <i>Terminal 29 Digital Input</i>	Par.6-11 <i>Terminal 53 High Voltage</i>
Par. 5-14 <i>Terminal 32 Digital Input</i>	Par. 6-12 <i>Terminal 53 Low Current</i>
Par. 5-15 <i>Terminal 33 Digital Input</i>	Par. 6-13 <i>Terminal 53 High Current</i>
	Par.6-14 <i>Terminal 53 Low Ref./Feedb. Value</i>
	Par.6-15 <i>Terminal 53 High Ref./Feedb. Value</i>

**Q3-3 Closed Loop Settings**

<b>Q3-30 Single Zone Int. Set Point</b>	<b>Q3-31 Single Zone Ext. Set Point</b>	<b>Q3-32 Multi Zone / Adv</b>
Par.1-00 Configuration Mode	Par.1-00 Configuration Mode	Par.1-00 Configuration Mode
Par. 20-12 Reference/Feedback Unit	Par. 20-12 Reference/Feedback Unit	Par.3-15 Reference 1 Source
Par. 20-13 Minimum Reference/Feedb.	Par. 20-13 Minimum Reference/Feedb.	Par.3-16 Reference 2 Source
Par. 20-14 Maximum Reference/Feedb.	Par. 20-14 Maximum Reference/Feedb.	Par.20-00 Feedback 1 Source
Par.6-22 Terminal 54 Low Current	Par.6-10 Terminal 53 Low Voltage	Par.20-01 Feedback 1 Conversion
Par.6-24 Terminal 54 Low Ref./Feedb. Value	Par.6-11 Terminal 53 High Voltage	Par. 20-02 Feedback 1 Source Unit
Par.6-25 Terminal 54 High Ref./Feedb. Value	Par. 6-12 Terminal 53 Low Current	Par.20-03 Feedback 2 Source
Par.6-26 Terminal 54 Filter Time Constant	Par. 6-13 Terminal 53 High Current	Par.20-04 Feedback 2 Conversion
Par.6-27 Terminal 54 Live Zero	Par.6-14 Terminal 53 Low Ref./Feedb. Value	Par. 20-05 Feedback 2 Source Unit
Par.6-00 Live Zero Timeout Time	Par.6-15 Terminal 53 High Ref./Feedb. Value	Par. 20-06 Feedback 3 Source
Par.6-01 Live Zero Timeout Function	Par.6-22 Terminal 54 Low Current	Par.20-07 Feedback 3 Conversion
Par.20-21 Setpoint 1	Par.6-24 Terminal 54 Low Ref./Feedb. Value	Par. 20-08 Feedback 3 Source Unit
Par.20-81 PID Normal/ Inverse Control	Par.6-25 Terminal 54 High Ref./Feedb. Value	Par. 20-12 Reference/Feedback Unit
Par. 20-82 PID Start Speed [RPM]	Par.6-26 Terminal 54 Filter Time Constant	Par. 20-13 Minimum Reference/Feedb.
Par. 20-83 PID Start Speed [Hz]	Par.6-27 Terminal 54 Live Zero	Par. 20-14 Maximum Reference/Feedb.
Par.20-93 PID Proportional Gain	Par.6-00 Live Zero Timeout Time	Par.6-10 Terminal 53 Low Voltage
Par.20-94 PID Integral Time	Par.6-01 Live Zero Timeout Function	Par.6-11 Terminal 53 High Voltage
Par. 20-70 Closed Loop Type	Par.20-81 PID Normal/ Inverse Control	Par. 6-12 Terminal 53 Low Current
Par. 20-71 PID Performance	Par. 20-82 PID Start Speed [RPM]	Par. 6-13 Terminal 53 High Current
Par. 20-72 PID Output Change	Par. 20-83 PID Start Speed [Hz]	Par.6-14 Terminal 53 Low Ref./Feedb. Value
Par. 20-73 Minimum Feedback Level	Par.20-93 PID Proportional Gain	Par.6-15 Terminal 53 High Ref./Feedb. Value
Par. 20-74 Maximum Feedback Level	Par.20-94 PID Integral Time	Par.6-16 Terminal 53 Filter Time Constant
Par. 20-79 PID Autotuning	Par. 20-70 Closed Loop Type	Par.6-17 Terminal 53 Live Zero
	Par. 20-71 PID Performance	Par.6-20 Terminal 54 Low Voltage
	Par. 20-72 PID Output Change	Par.6-21 Terminal 54 High Voltage
	Par. 20-73 Minimum Feedback Level	Par.6-22 Terminal 54 Low Current
	Par. 20-74 Maximum Feedback Level	Par.6-23 Terminal 54 High Current
	Par. 20-79 PID Autotuning	Par.6-24 Terminal 54 Low Ref./Feedb. Value
		Par.6-25 Terminal 54 High Ref./Feedb. Value
		Par.6-26 Terminal 54 Filter Time Constant
		Par.6-27 Terminal 54 Live Zero
		Par.6-00 Live Zero Timeout Time
		Par.6-01 Live Zero Timeout Function
		Par.4-56 Warning Feedback Low
		Par.4-57 Warning Feedback High
		Par.20-20 Feedback Function
		Par.20-21 Setpoint 1
		Par.20-22 Setpoint 2
		Par.20-81 PID Normal/ Inverse Control
		Par. 20-82 PID Start Speed [RPM]
		Par. 20-83 PID Start Speed [Hz]
		Par.20-93 PID Proportional Gain
		Par.20-94 PID Integral Time
		Par. 20-70 Closed Loop Type
		Par. 20-71 PID Performance
		Par. 20-72 PID Output Change
		Par. 20-73 Minimum Feedback Level
		Par. 20-74 Maximum Feedback Level
		Par. 20-79 PID Autotuning

Q3-4 Application Settings		
Q3-40 Fan Functions	Q3-41 Pump Functions	Q3-42 Compressor Functions
Par.22-60 <i>Broken Belt Function</i>	Par. 22-20 <i>Low Power Auto Set-up</i>	Par.1-03 <i>Torque Characteristics</i>
Par.22-61 <i>Broken Belt Torque</i>	Par.22-21 <i>Low Power Detection</i>	Par.1-71 <i>Start Delay</i>
Par.22-62 <i>Broken Belt Delay</i>	Par.22-22 <i>Low Speed Detection</i>	Par.22-75 <i>Short Cycle Protection</i>
Par.4-64 <i>Semi-Auto Bypass Set-up</i>	Par.22-23 <i>No-Flow Function</i>	Par.22-76 <i>Interval between Starts</i>
Par.1-03 <i>Torque Characteristics</i>	Par.22-24 <i>No-Flow Delay</i>	Par.22-77 <i>Minimum Run Time</i>
Par.22-22 <i>Low Speed Detection</i>	Par.22-40 <i>Minimum Run Time</i>	Par.5-01 <i>Terminal 27 Mode</i>
Par.22-23 <i>No-Flow Function</i>	Par.22-41 <i>Minimum Sleep Time</i>	Par.5-02 <i>Terminal 29 Mode</i>
Par.22-24 <i>No-Flow Delay</i>	Par.22-42 <i>Wake-up Speed [RPM]</i>	Par. 5-12 <i>Terminal 27 Digital Input</i>
Par.22-40 <i>Minimum Run Time</i>	Par.22-43 <i>Wake-up Speed [Hz]</i>	Par. 5-13 <i>Terminal 29 Digital Input</i>
Par.22-41 <i>Minimum Sleep Time</i>	Par.22-44 <i>Wake-up Ref./FB Difference</i>	Par.5-40 <i>Function Relay</i>
Par.22-42 <i>Wake-up Speed [RPM]</i>	Par. 22-45 <i>Setpoint Boost</i>	Par.1-73 <i>Flying Start</i>
Par.22-43 <i>Wake-up Speed [Hz]</i>	Par. 22-46 <i>Maximum Boost Time</i>	Par. 1-86 <i>Trip Speed Low [RPM]</i>
Par.22-44 <i>Wake-up Ref./FB Difference</i>	Par.22-26 <i>Dry Pump Function</i>	Par. 1-87 <i>Trip Speed Low [Hz]</i>
Par. 22-45 <i>Setpoint Boost</i>	Par. 22-27 <i>Dry Pump Delay</i>	
Par. 22-46 <i>Maximum Boost Time</i>	Par. 22-80 <i>Flow Compensation</i>	
Par.2-10 <i>Brake Function</i>	Par. 22-81 <i>Square-linear Curve Approximation</i>	
Par. 2-16 <i>AC brake Max. Current</i>	Par. 22-82 <i>Work Point Calculation</i>	
Par.2-17 <i>Over-voltage Control</i>	Par. 22-83 <i>Speed at No-Flow [RPM]</i>	
Par.1-73 <i>Flying Start</i>	Par. 22-84 <i>Speed at No-Flow [Hz]</i>	
Par.1-71 <i>Start Delay</i>	Par. 22-85 <i>Speed at Design Point [RPM]</i>	
Par.1-80 <i>Function at Stop</i>	Par. 22-86 <i>Speed at Design Point [Hz]</i>	
Par.2-00 <i>DC Hold/Preheat Current</i>	Par. 22-87 <i>Pressure at No-Flow Speed</i>	
Par.4-10 <i>Motor Speed Direction</i>	Par. 22-88 <i>Pressure at Rated Speed</i>	
	Par. 22-89 <i>Flow at Design Point</i>	
	Par. 22-90 <i>Flow at Rated Speed</i>	
	Par.1-03 <i>Torque Characteristics</i>	
	Par.1-73 <i>Flying Start</i>	

See also for a detailed description of the Function Setups parameter groups.

**1-00 Configuration Mode**

Option:	Function:
[0] *    Open Loop	Motor speed is determined by applying a speed reference or by setting desired speed when in Hand Mode.  Open Loop is also used if the frequency converter is part of a closed loop control system based on an external PID controller providing a speed reference signal as output.
[3]        Closed Loop	Motor Speed will be determined by a reference from the built-in PID controller varying the motor speed as part of a closed loop control process (e.g. constant pressure or flow). The PID controller must be configured in par. 20-** or via the Function Setups accessed by pressing the [Quick Menu] button.

**NB!**  
This parameter cannot be changed when motor is running.

**NB!**  
When set for Closed Loop, the commands Reversing and Start Reversing will not reverse the direction of the motor.



**1-03 Torque Characteristics**

**Option:**

**Function:**

[0] *	Compressor torque	<i>Compressor</i> [0]: For speed control of screw and scroll compressors. Provides a voltage which is optimized for a constant torque load characteristic of the motor in the entire range down to 10 Hz.
[1]	Variable torque	<i>Variable Torque</i> [1]: For speed control of centrifugal pumps and fans. Also to be used when controlling more than one motor from the same frequency converter (e.g. multiple condenser fans or cooling tower fans). Provides a voltage which is optimized for a squared torque load characteristic of the motor.
[2]	Auto Energy Optim. CT	<i>Auto Energy Optimization Compressor</i> [2]: For optimum energy efficient speed control of screw and scroll compressors. Provides a voltage which is optimized for a constant torque load characteristic of the motor in the entire range down to 15Hz but in addition the AEO feature will adapt the voltage exactly to the current load situation, thereby reducing energy consumption and audible noise from the motor. To obtain optimal performance, the motor power factor cos phi must be set correctly. This value is set in par. 14-43 <i>Motor Cosphi</i> . The parameter has a default value which is automatically adjusted when the motor data is programmed. These settings will typically ensure optimum motor voltage but if the motor power factor cos phi requires tuning, an AMA function can be carried out using par.1-29 <i>Automatic Motor Adaptation (AMA)</i> . It is very rarely necessary to adjust the motor power factor parameter manually.
[3] *	Auto Energy Optim. VT	<i>Auto Energy Optimization VT</i> [3]: For optimum energy efficient speed control of centrifugal pumps and fans. Provides a voltage which is optimized for a squared torque load characteristic of the motor but in addition the AEO feature will adapt the voltage exactly to the current load situation, thereby reducing energy consumption and audible noise from the motor. To obtain optimal performance, the motor power factor cos phi must be set correctly. This value is set in par. 14-43 <i>Motor Cosphi</i> . The parameter has a default value and is automatically adjusted when the motor data is programmed. These settings will typically ensure optimum motor voltage but if the motor power factor cos phi requires tuning, an AMA function can be carried out using par.1-29 <i>Automatic Motor Adaptation (AMA)</i> . It is very rarely necessary to adjust the motor power factor parameter manually.

**1-29 Automatic Motor Adaptation (AMA)**

**Option:**

**Function:**

		The AMA function optimizes dynamic motor performance by automatically optimizing the advanced motor parameters par. 1-30 <i>Stator Resistance (Rs)</i> to par. 1-35 <i>Main Reactance (Xh)</i> while the motor is stationary.
[0] *	Off	No function
[1]	Enable complete AMA	performs AMA of the stator resistance $R_s$ , the rotor resistance $R_r$ , the stator leakage reactance $X_{1l}$ , the rotor leakage reactance $X_{2l}$ and the main reactance $X_h$ .
[2]	Enable reduced AMA	performs a reduced AMA of the stator resistance $R_s$ in the system only. Select this option if an LC filter is used between the frequency converter and the motor.

Activate the AMA function by pressing [Hand on] after selecting [1] or [2]. See also the item *Automatic Motor Adaptation* in the Design Guide. After a normal sequence, the display will read: "Press [OK] to finish AMA". After pressing the [OK] key the frequency converter is ready for operation.

Note:

- For the best adaptation of the frequency converter, run AMA on a cold motor
- AMA cannot be performed while the motor is running

**NB!**  
It is important to set motor par. 1-2\* Motor Data correctly, since these form part of the AMA algorithm. An AMA must be performed to achieve optimum dynamic motor performance. It may take up to 10 min., depending on motor power rating.

**NB!**

Avoid generating external torque during AMA.

**NB!**

If one of the settings in par. 1-2\* Motor Data is changed, par. 1-30 *Stator Resistance (Rs)* to par.1-39 *Motor Poles*, the advanced motor parameters, will return to default setting.

This parameter cannot be adjusted while the motor is running.

**NB!**

Full AMA should be run without filter only while reduced AMA should be run with filter.

## 6

See section: *Application Examples > Automatic Motor Adaptation* in the Design Guide.

### 1-71 Start Delay

**Range:**

0.0 s\* [0.0 - 120.0 s]

**Function:**

The function selected in par.1-80 *Function at Stop* is active in the delay period.  
Enter the time delay required before commencing acceleration.

### 1-73 Flying Start

**Option:**

[0] \* Disabled  
[1] Enabled

**Function:**

This function makes it possible to catch a motor which is spinning freely due to a mains drop-out.  
When par.1-73 *Flying Start* is enabled, par.1-71 *Start Delay* has no function.  
Search direction for flying start is linked to the setting in par.4-10 *Motor Speed Direction*.  
*Clockwise* [0]: Flying start search in clockwise direction. If not successful, a DC brake is carried out.  
*Both Directions* [2]: The flying start will first make a search in the direction determined by the last reference (direction). If not finding the speed it will make a search in the other direction. If not successful, a DC brake will be activated in the time set in par. 2-02 *DC Braking Time*. Start will then take place from 0 Hz.

Select *Disable* [0] if this function is not required

Select *Enable* [1] to enable the frequency converter to "catch" and control a spinning motor.

### 1-80 Function at Stop

**Option:**

[0] \* Coast  
[1] DC Hold/Motor Preheat

**Function:**

Select the frequency converter function after a stop command or after the speed is ramped down to the settings in par. 1-81 *Min Speed for Function at Stop [RPM]*.

Leaves motor in free mode.

Energizes motor with a DC holding current (see par.2-00 *DC Hold/Preheat Current*).

### 1-90 Motor Thermal Protection

**Option:****Function:**

The frequency converter determines the motor temperature for motor protection in two different ways:

- Via a thermistor sensor connected to one of the analog or digital inputs (par.1-93 *Thermistor Source*).
- Via calculation (ETR = Electronic Thermal Relay) of the thermal load, based on the actual load and time. The calculated thermal load is compared with the rated motor current  $I_{M,N}$  and the rated motor frequency  $f_{M,N}$ . The calculations estimate the need for a lower load at lower speed due to less cooling from the fan incorporated in the motor.

[0]	No protection	If the motor is continuously overloaded and no warning or trip of frequency converter is wanted.
[1]	Thermistor warning	Activates a warning when the connected thermistor in the motor reacts in the event of motor over-temperature.
[2]	Thermistor trip	Stops (trips) the frequency converter when the connected thermistor in the motor reacts in the event of motor over-temperature.
[3]	ETR warning 1	
[4] *	ETR trip 1	
[5]	ETR warning 2	
[6]	ETR trip 2	
[7]	ETR warning 3	
[8]	ETR trip 3	
[9]	ETR warning 4	
[10]	ETR trip 4	

ETR (Electronic Thermal Relay) functions 1-4 will calculate the load when set-up where they were selected is active. For example ETR-3 starts calculating when set-up 3 is selected. For the North American market: The ETR functions provide class 20 motor overload protection in accordance with NEC.

**6**

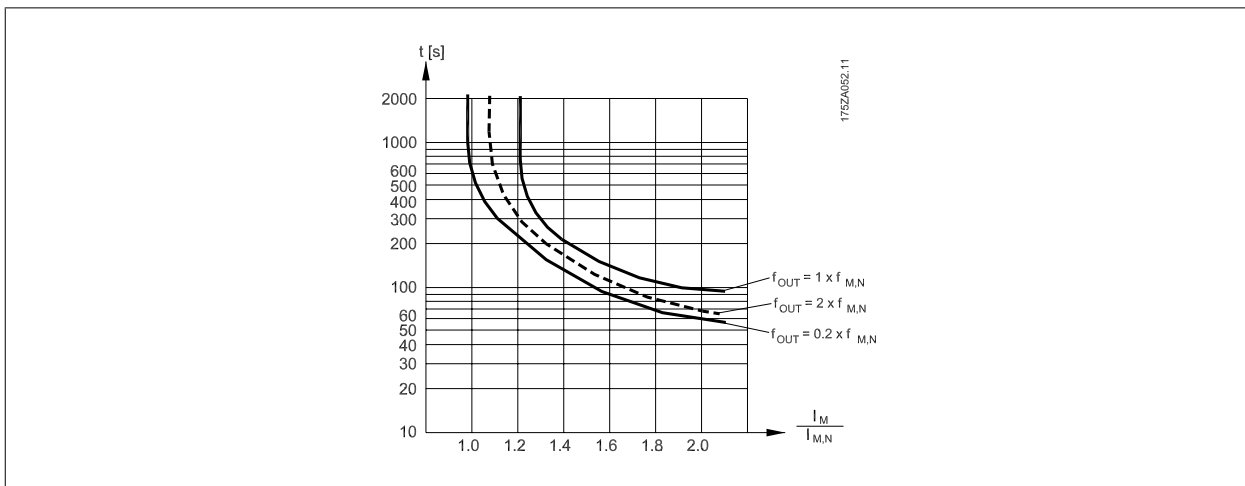

**NB!**  
Armstrong recommends using 24 VDC as thermistor supply voltage.

**1-93 Thermistor Source**

**Option:**

**Function:**

Select the input to which the thermistor (PTC sensor) should be connected. An analog input option [1] or [2] cannot be selected if the analog input is already in use as a reference source (selected in par.3-15 *Reference 1 Source*, par.3-16 *Reference 2 Source* or par. 3-17 *Reference 3 Source*).  
When using MCB112, choice [0] *None* must always be selected.

[0] *	None
[1]	Analog input 53
[2]	Analog input 54
[3]	Digital input 18
[4]	Digital input 19
[5]	Digital input 32
[6]	Digital input 33

**NB!**

This parameter cannot be adjusted while the motor is running.

**NB!**

Digital input should be set to [0] *PNP - Active at 24V* in parameter 5-00.

### 2-00 DC Hold/Preheat Current

**Range:**

50 %\* [Application dependant]

**Function:**

Enter a value for holding current as a percentage of the rated motor current  $I_{M,N}$  set in par. 1-24 *Motor Current*. 100% DC holding current corresponds to  $I_{M,N}$ .

This parameter holds the motor (holding torque) or pre-heats the motor.

This parameter is active if [1] DC hold/Preheat is selected in par.1-80 *Function at Stop*.

6

**NB!**

The maximum value depends on the rated motor current.

**NB!**

Avoid 100 % current for too long. It may damage the motor.

### 2-10 Brake Function

**Option:**

[0] \* Off

**Function:**

No brake resistor installed.

[1] Resistor brake

Brake resistor incorporated in the system, for dissipation of surplus brake energy as heat. Connecting a brake resistor allows a higher DC link voltage during braking (generating operation). The Resistor brake function is only active in frequency converters with an integral dynamic brake.

[2] AC brake

AC Brake will only work in Compressor Torque mode in par.1-03 *Torque Characteristics*.

### 2-17 Over-voltage Control

**Option:**

[0] Disabled

**Function:**

Over-voltage control (OVC) reduces the risk of the frequency converter tripping due to an over voltage on the DC link caused by generative power from the load.

[2] \* Enabled

Activates OVC.

**NB!**

The ramp time is automatically adjusted to avoid tripping of the frequency converter.

### 3-02 Minimum Reference

**Range:**

Application dependent\* [Application dependant]

**Function:**

### 3-03 Maximum Reference

**Range:**

Application dependent\* [Application dependant]

**Function:**

### 3-10 Preset Reference

Array [8]

**Range:**

0.00 %\* [-100.00 - 100.00 %]

**Function:**

Enter up to eight different preset references (0-7) in this parameter, using array programming. The preset reference is stated as a percentage of the value Ref<sub>MAX</sub> (par.3-03 *Maximum Reference*, for closed loop see par. 20-14 *Maximum Reference/Feedb.*). When using preset references, select Preset ref. bit 0 / 1 / 2 [16], [17] or [18] for the corresponding digital inputs in parameter group 5-1\* Digital Inputs.

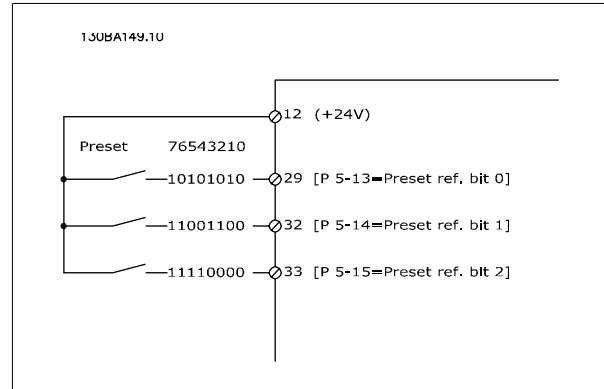
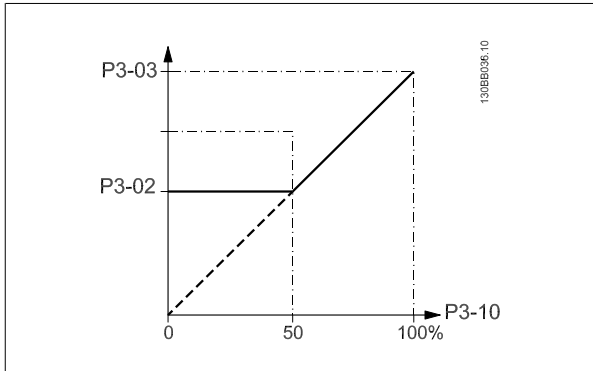

6

### 3-15 Reference 1 Source

**Option:**

**Function:**

Select the reference input to be used for the first reference signal. par.3-15 *Reference 1 Source*, par.3-16 *Reference 2 Source* and par. 3-17 *Reference 3 Source* define up to three different reference signals. The sum of these reference signals defines the actual reference.

This parameter cannot be adjusted while the motor is running.

[0] No function

[1] \* Analog input 53

[2] Analog input 54

[7] Pulse input 29

[8] Pulse input 33

[20] Digital pot.meter

[21] Analog input X30/11

[22] Analog input X30/12

[23] Analog Input X42/1

[24] Analog Input X42/3

[25] Analog Input X42/5

[30] Ext. Closed Loop 1

[31] Ext. Closed Loop 2

[32] Ext. Closed Loop 3

### 3-16 Reference 2 Source

**Option:**

**Function:**

Select the reference input to be used for the second reference signal. par.3-15 *Reference 1 Source*, par.3-16 *Reference 2 Source* and par. 3-17 *Reference 3 Source* define up to three different reference signals. The sum of these reference signals defines the actual reference.

This parameter cannot be adjusted while the motor is running.

[0] No function

[1] Analog input 53

[2]	Analog input 54
[7]	Pulse input 29
[8]	Pulse input 33
[20] *	Digital pot.meter
[21]	Analog input X30/11
[22]	Analog input X30/12
[23]	Analog Input X42/1
[24]	Analog Input X42/3
[25]	Analog Input X42/5
[30]	Ext. Closed Loop 1
[31]	Ext. Closed Loop 2
[32]	Ext. Closed Loop 3

**4-10 Motor Speed Direction**

Option:	Function:
	Selects the motor speed direction required. Use this parameter to prevent unwanted reversing.
[0]	Clockwise Only operation in clockwise direction will be allowed.
[2] *	Both directions Operation in both clockwise and anti-clockwise direction will be allowed.



**NB!**

The setting in par.4-10 *Motor Speed Direction* has impact on the Flying Start in par.1-73 *Flying Start*.

**4-53 Warning Speed High**

Range:	Function:
Application [Application dependant] dependent*	



**NB!**

Any changes in par.4-13 *Motor Speed High Limit [RPM]* will reset the value in par.4-53 *Warning Speed High* to the same value as set in par.4-13 *Motor Speed High Limit [RPM]*.  
If a different value is needed in par.4-53 *Warning Speed High*, it must be set after programming of par.4-13 *Motor Speed High Limit [RPM]*.

**4-56 Warning Feedback Low**

Range:	Function:
-999999.99 [Application dependant] 9 Proc- essCtrlU- nit*	Enter the lower feedback limit. When the feedback falls below this limit, the display reads Feedb Low. The signal outputs can be programmed to produce a status signal on terminal 27 or 29 and on relay output 01 or 02.

**4-57 Warning Feedback High**

Range:	Function:
999999.999 [Application dependant] ProcessCtr- IUnit*	Enter the upper feedback limit. When the feedback exceeds this limit, the display reads Feedb High. The signal outputs can be programmed to produce a status signal on terminal 27 or 29 and on relay output 01 or 02.

**4-64 Semi-Auto Bypass Set-up**

<b>Option:</b>		<b>Function:</b>
[0] *	Off	No function
[1]	Enabled	Starts the Semi-Automatic Bypass set-up and continue with the procedure described above.

**5-01 Terminal 27 Mode**

<b>Option:</b>		<b>Function:</b>
[0] *	Input	Defines terminal 27 as a digital input.
[1]	Output	Defines terminal 27 as a digital output.

Please note that this parameter cannot be adjusted while the motor is running.

**5-02 Terminal 29 Mode**

<b>Option:</b>		<b>Function:</b>
[0] *	Input	Defines terminal 29 as a digital input.
[1]	Output	Defines terminal 29 as a digital output.

This parameter cannot be adjusted while the motor is running.

### 6.1.4 5-1\* Digital Inputs

Parameters for configuring the input functions for the input terminals.

The digital inputs are used for selecting various functions in the frequency converter. All digital inputs can be set to the following functions:

Digital input function	Select	Terminal
No operation	[0]	All *terminal 19, 32, 33
Reset	[1]	All
Coast inverse	[2]	27
Coast and reset inverse	[3]	All
DC-brake inverse	[5]	All
Stop inverse	[6]	All
External interlock	[7]	All
Start	[8]	All *terminal 18
Latched start	[9]	All
Reversing	[10]	All
Start reversing	[11]	All
Jog	[14]	All *terminal 29
Preset reference on	[15]	All
Preset ref bit 0	[16]	All
Preset ref bit 1	[17]	All
Preset ref bit 2	[18]	All
Freeze reference	[19]	All
Freeze output	[20]	All
Speed up	[21]	All
Speed down	[22]	All
Set-up select bit 0	[23]	All
Set-up select bit 1	[24]	All
Pulse input	[32]	terminal 29, 33
Ramp bit 0	[34]	All
Mains failure inverse	[36]	All
Fire mode	[37]	All
Run Permissive	[52]	All
Hand start	[53]	All
Auto start	[54]	All
DigiPot Increase	[55]	All
DigiPot Decrease	[56]	All
DigiPot Clear	[57]	All
Counter A (up)	[60]	29, 33
Counter A (down)	[61]	29, 33
Reset Counter A	[62]	All
Counter B (up)	[63]	29, 33
Counter B (down)	[64]	29, 33
Reset Counter B	[65]	All
Sleep Mode	[66]	All
Reset Maintenance Word	[78]	All
Lead Pump Start	[120]	All
Lead Pump Alternation	[121]	All
Pump 1 Interlock	[130]	All
Pump 2 Interlock	[131]	All
Pump 3 Interlock	[132]	All

#### 5-12 Terminal 27 Digital Input

Same options and functions as par. 5-1\*, except for *Pulse input*.

#### Option:

#### Function:

[0] \* No operation



### 5-13 Terminal 29 Digital Input

Same options and functions as par. 5-1\*.

**Option:** **Function:**

[14] \* Jog

### 5-14 Terminal 32 Digital Input

Same options and functions as par. 5-1\*, except for *Pulse input*.

**Option:** **Function:**

[0] \* No operation

### 5-15 Terminal 33 Digital Input

Same options and functions as par. 5-1\* Digital Inputs.

**Option:** **Function:**

[0] \* No operation

### 5-40 Function Relay

Array [8]

(Relay 1 [0], Relay 2 [1])

Option MCB 105: Relay 7 [6], Relay 8 [7] and Relay 9 [8]).

Select options to define the function of the relays.

The selection of each mechanical relay is realised in an array parameter.

**Option:** **Function:**

[0] \* No operation

[1] Control ready

[2] Drive ready

[3] Drive rdy/rem ctrl

[4] Standby / no warning

[5] \* Running Default setting for relay 2.

[6] Running / no warning

[8] Run on ref/no warn

[9] \* Alarm Default setting for relay 1.

[10] Alarm or warning

[11] At torque limit

[12] Out of current range

[13] Below current, low

[14] Above current, high

[15] Out of speed range

[16] Below speed, low

[17] Above speed, high

[18] Out of feedb. range

[19] Below feedback, low

[20] Above feedback, high

[21] Thermal warning

[25] Reverse

[26] Bus OK

[27] Torque limit & stop

[28] Brake, no brake war

[29] Brake ready, no fault

[30] Brake fault (IGBT)

[35]	External Interlock
[36]	Control word bit 11
[37]	Control word bit 12
[40]	Out of ref range
[41]	Below reference, low
[42]	Above ref, high
[45]	Bus ctrl.
[46]	Bus ctrl, 1 if timeout
[47]	Bus ctrl, 0 if timeout
[60]	Comparator 0
[61]	Comparator 1
[62]	Comparator 2
[63]	Comparator 3
[64]	Comparator 4
[65]	Comparator 5
[70]	Logic rule 0
[71]	Logic rule 1
[72]	Logic rule 2
[73]	Logic rule 3
[74]	Logic rule 4
[75]	Logic rule 5
[80]	SL digital output A
[81]	SL digital output B
[82]	SL digital output C
[83]	SL digital output D
[84]	SL digital output E
[85]	SL digital output F
[160]	No alarm
[161]	Running reverse
[165]	Local ref active
[166]	Remote ref active
[167]	Start command act.
[168]	Hand mode
[169]	Auto mode
[180]	Clock Fault
[181]	Prev. Maintenance
[190]	No-Flow
[191]	Dry Pump
[192]	End Of Curve
[193]	Sleep Mode
[194]	Broken Belt
[195]	Bypass Valve Control
[196]	Fire Mode
[197]	Fire Mode was Act.
[198]	Drive Bypass
[211]	Cascade Pump 1
[212]	Cascade Pump 2

[213] Cascade Pump 3

**6-00 Live Zero Timeout Time**

**Range:**

10 s\* [1 - 99 s]

**Function:**

Enter the Live Zero Time-out time period. Live Zero Time-out Time is active for analog inputs, i.e. terminal 53 or terminal 54, used as reference or feedback sources. If the reference signal value associated with the selected current input falls below 50% of the value set in par.6-10 *Terminal 53 Low Voltage*, par. 6-12 *Terminal 53 Low Current*, par.6-20 *Terminal 54 Low Voltage* or par. 6-22 *Terminal 54 Low Current* for a time period longer than the time set in par.6-00 *Live Zero Timeout Time*, the function selected in par.6-01 *Live Zero Timeout Function* will be activated.

**6-01 Live Zero Timeout Function**

**Option:**

**Function:**

Select the time-out function. The function set in par.6-01 *Live Zero Timeout Function* will be activated if the input signal on terminal 53 or 54 is below 50% of the value in par.6-10 *Terminal 53 Low Voltage*, par. 6-12 *Terminal 53 Low Current*, par.6-20 *Terminal 54 Low Voltage* or par. 6-22 *Terminal 54 Low Current* for a time period defined in par.6-00 *Live Zero Timeout Time*. If several time-outs occur simultaneously, the frequency converter prioritises the time-out functions as follows:

1. Par.6-01 *Live Zero Timeout Function*
2. Par. 8-04 *Control Timeout Function*

The output frequency of the frequency converter can be:

- [1] frozen at the present value
- [2] overruled to stop
- [3] overruled to jog speed
- [4] overruled to max. speed
- [5] overruled to stop with subsequent trip

[0] \* Off

[1] Freeze output

[2] Stop

[3] Jogging

[4] Max. speed

[5] Stop and trip

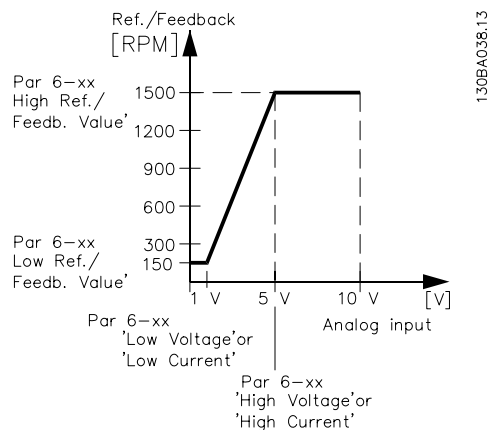

### 6-10 Terminal 53 Low Voltage

**Range:**

0.07 V\* [Application dependant]

**Function:**

Enter the low voltage value. This analog input scaling value should correspond to the low reference/feedback value set in par.6-14 *Terminal 53 Low Ref./Feedb. Value*.

### 6-11 Terminal 53 High Voltage

**Range:**

10.00 V\* [Application dependant]

**Function:**

Enter the high voltage value. This analog input scaling value should correspond to the high reference/feedback value set in par.6-15 *Terminal 53 High Ref./Feedb. Value*.

### 6-14 Terminal 53 Low Ref./Feedb. Value

**Range:**

0.000 N/A\* [-999999.999 - 999999.999 N/A]

**Function:**

Enter the analog input scaling value that corresponds to the low voltage/low current set in par. 6-10 *Terminal 53 Low Voltage* and par. 6-12 *Terminal 53 Low Current*.

### 6-15 Terminal 53 High Ref./Feedb. Value

**Range:**

Application dependent\* [-999999.999 - 999999.999 N/A]

**Function:**

Enter the analog input scaling value that corresponds to the high voltage/high current value set in par.6-11 *Terminal 53 High Voltage* and par. 6-13 *Terminal 53 High Current*.

### 6-16 Terminal 53 Filter Time Constant

**Range:**

0.001 s\* [0.001 - 10.000 s]

**Function:**

Enter the time constant. This is a first-order digital low pass filter time constant for suppressing electrical noise in terminal 53. A high time constant value improves dampening but also increases the time delay through the filter.

This parameter cannot be adjusted while the motor is running.

### 6-17 Terminal 53 Live Zero

**Option:**

[0] Disabled

[1]\* Enabled

**Function:**

This parameter makes it possible to disable the Live Zero monitoring. E.g. to be used if the analog outputs are used as part of a de-central I/O system (e.g. when not as part of any frequency converter related control functions, but feeding a Building Management system with data).

### 6-20 Terminal 54 Low Voltage

**Range:**

0.07 V\* [Application dependant]

**Function:**

Enter the low voltage value. This analog input scaling value should correspond to the low reference/feedback value, set in par.6-24 *Terminal 54 Low Ref./Feedb. Value*.

### 6-21 Terminal 54 High Voltage

**Range:**

10.00 V\* [Application dependant]

**Function:**

Enter the high voltage value. This analog input scaling value should correspond to the high reference/feedback value set in par.6-25 *Terminal 54 High Ref./Feedb. Value*.

### 6-24 Terminal 54 Low Ref./Feedb. Value

**Range:**

0.000 N/A\* [-999999.999 - 999999.999 N/A]

**Function:**

Enter the analog input scaling value that corresponds to the low voltage/low current value set in par.6-20 *Terminal 54 Low Voltage* and par.6-22 *Terminal 54 Low Current*.

### 6-25 Terminal 54 High Ref./Feedb. Value

**Range:**

100.000 N/ [-999999.999 - 999999.999 N/A] A\*

**Function:**

Enter the analog input scaling value that corresponds to the high voltage/high current value set in par.6-21 *Terminal 54 High Voltage* and par.6-23 *Terminal 54 High Current*.

### 6-26 Terminal 54 Filter Time Constant

**Range:**

0.001 s\* [0.001 - 10.000 s]

**Function:**

Enter the time constant. This is a first-order digital low pass filter time constant for suppressing electrical noise in terminal 54. A high time constant value improves dampening but also increases the time delay through the filter.

This parameter cannot be adjusted while the motor is running.

### 6-27 Terminal 54 Live Zero

**Option:**

- [0] Disabled
- [1] \* Enabled

**Function:**

This parameter makes it possible to disable the Live Zero monitoring. E.g. to be used if the analog outputs are used as part of a de-central I/O system (e.g. when not as part of any frequency converter related control functions, but feeding a Building Management System with data).



### 6-50 Terminal 42 Output

**Option:**

- [0] \* No operation

**Function:**

Select the function of Terminal 42 as an analog current output. A motor current of 20 mA corresponds to  $I_{max}$ .

- [100] Output freq. 0-100 : 0 - 100 Hz, (0-20 mA)
- [101] Reference Min-Max : Minimum reference - Maximum reference, (0-20 mA)
- [102] Feedback +-200% : -200% to +200% of par. 20-14 *Maximum Reference/Feedb.*, (0-20 mA)
- [103] Motor cur. 0-Imax : 0 - Inverter Max. Current (par. 16-37 *Inv. Max. Current*), (0-20 mA)
- [104] Torque 0-Tlim : 0 - Torque limit (par. 4-16 *Torque Limit Motor Mode*), (0-20 mA)
- [105] Torque 0-Tnom : 0 - Motor rated torque, (0-20 mA)
- [106] Power 0-Pnom : 0 - Motor rated power, (0-20 mA)
- [107] \* Speed 0-HighLim : 0 - Speed High Limit (par.4-13 *Motor Speed High Limit [RPM]* and par.4-14 *Motor Speed High Limit [Hz]*), (0-20 mA)
- [113] Ext. Closed Loop 1 : 0 - 100%, (0-20 mA)
- [114] Ext. Closed Loop 2 : 0 - 100%, (0-20 mA)
- [115] Ext. Closed Loop 3 : 0 - 100%, (0-20 mA)
- [130] Out frq 0-100 4-20mA : 0 - 100 Hz
- [131] Reference 4-20mA : Minimum Reference - Maximum Reference
- [132] Feedback 4-20mA : -200% to +200% of par. 20-14 *Maximum Reference/Feedb.*
- [133] Motor cur. 4-20mA : 0 - Inverter Max. Current (par. 16-37 *Inv. Max. Current*)
- [134] Torq.0-lim 4-20 mA : 0 - Torque limit (par. 4-16 *Torque Limit Motor Mode*)
- [135] Torq.0-nom 4-20mA : 0 - Motor rated torque
- [136] Power 4-20mA : 0 - Motor rated power
- [137] Speed 4-20mA : 0 - Speed High Limit (4-13 and 4-14)

[139]	Bus ctrl.	: 0 - 100%, (0-20 mA)
[140]	Bus ctrl. 4-20 mA	: 0 - 100%
[141]	Bus ctrl t.o.	: 0 - 100%, (0-20 mA)
[142]	Bus ctrl t.o. 4-20mA	: 0 - 100%
[143]	Ext. CL 1 4-20mA	: 0 - 100%
[144]	Ext. CL 2 4-20mA	: 0 - 100%
[145]	Ext. CL 3 4-20mA	: 0 - 100%

**NB!**  
 Values for setting the Minimum Reference is found in open loop par.3-02 *Minimum Reference* and for closed loop par. 20-13 *Minimum Reference/Feedb.* - values for maximum reference for open loop is found in par.3-03 *Maximum Reference* and for closed loop par. 20-14 *Maximum Reference/Feedb.*

6

**6-51 Terminal 42 Output Min Scale**

**Range:** 0.00 %\* [0.00 - 200.00 %]  
**Function:** Scale for the minimum output (0 or 4 mA) of the analogue signal at terminal 42. Set the value to be the **percentage** of the full range of the variable selected in par.6-50 *Terminal 42 Output*.

**6-52 Terminal 42 Output Max Scale**

**Range:** 100.00 %\* [0.00 - 200.00 %]  
**Function:** Scale for the maximum output (20 mA) of the analog signal at terminal 42. Set the value to be the percentage of the full range of the variable selected in par.6-50 *Terminal 42 Output*.

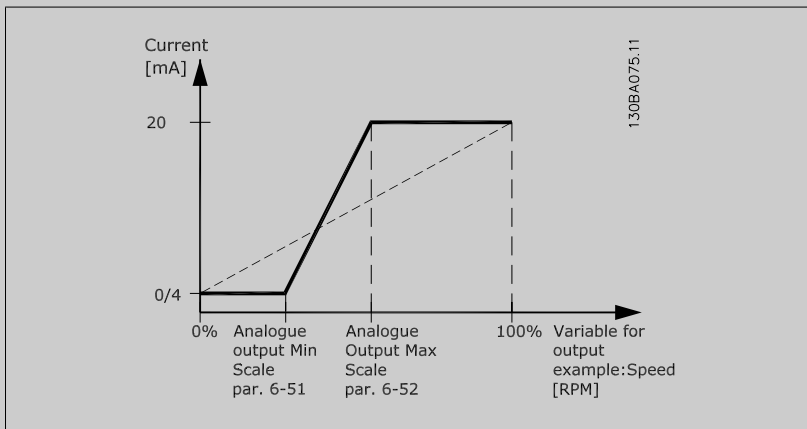

It is possible to get a value lower than 20 mA at full scale by programming values >100% by using a formula as follows:

$$20 \text{ mA} / \text{desired maximum current} \times 100 \%$$

i.e.  $10 \text{ mA} : \frac{20 \text{ mA}}{10 \text{ mA}} \times 100 \% = 200 \%$

**EXAMPLE 1:**

Variable value= OUTPUT FREQUENCY, range = 0-100 Hz

Range needed for output = 0-50 Hz

Output signal 0 or 4 mA is needed at 0 Hz (0% of range) - set par.6-51 *Terminal 42 Output Min Scale* to 0%

Output signal 20 mA is needed at 50 Hz (50% of range) - set par.6-52 *Terminal 42 Output Max Scale* to 50%

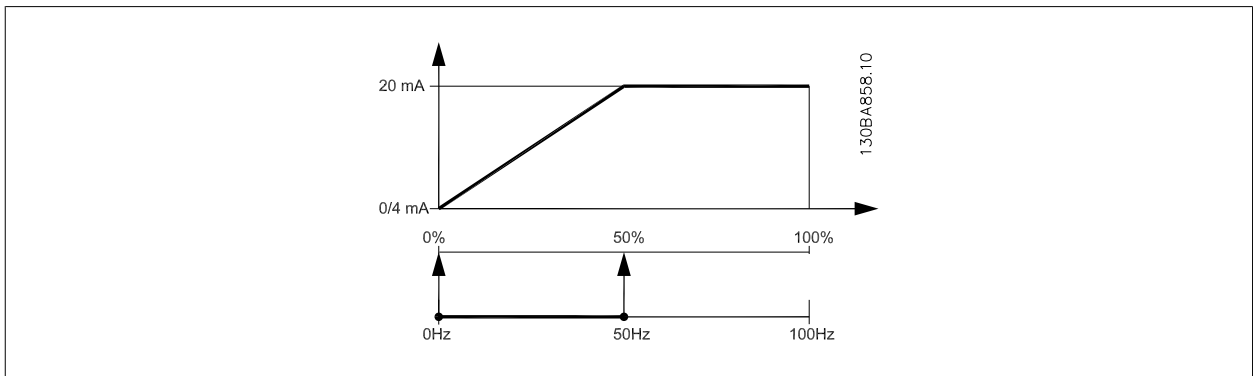

EXAMPLE 2:

Variable= FEEDBACK, range= -200% to +200%

Range needed for output= 0-100%

Output signal 0 or 4 mA is needed at 0% (50% of range) - set par.6-51 Terminal 42 Output Min Scale to 50%

Output signal 20 mA is needed at 100% (75% of range) - set par.6-52 Terminal 42 Output Max Scale to 75%

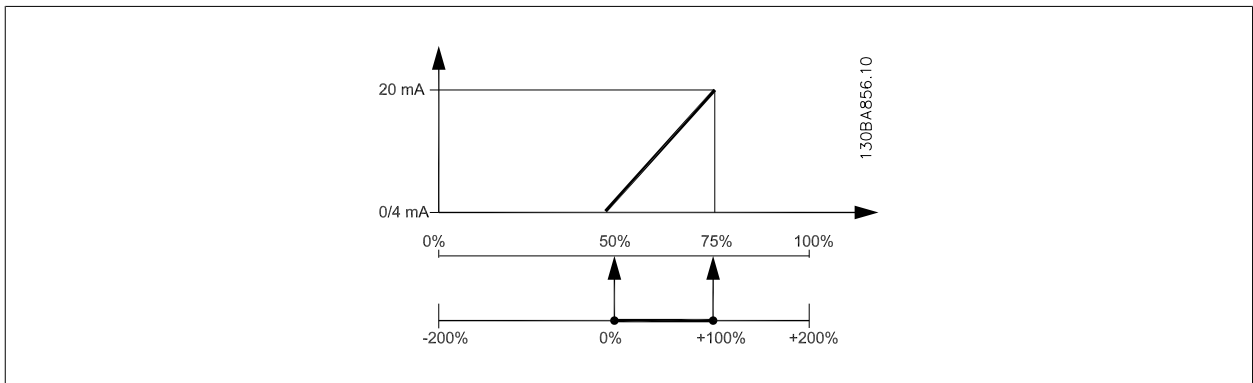

EXAMPLE 3:

Variable value= REFERENCE, range= Min ref - Max ref

Range needed for output= Min ref (0%) - Max ref (100%), 0-10 mA

Output signal 0 or 4 mA is needed at Min ref - set par.6-51 Terminal 42 Output Min Scale to 0%

Output signal 10 mA is needed at Max ref (100% of range) - set par.6-52 Terminal 42 Output Max Scale to 200%

(20 mA / 10 mA x 100%=200%).

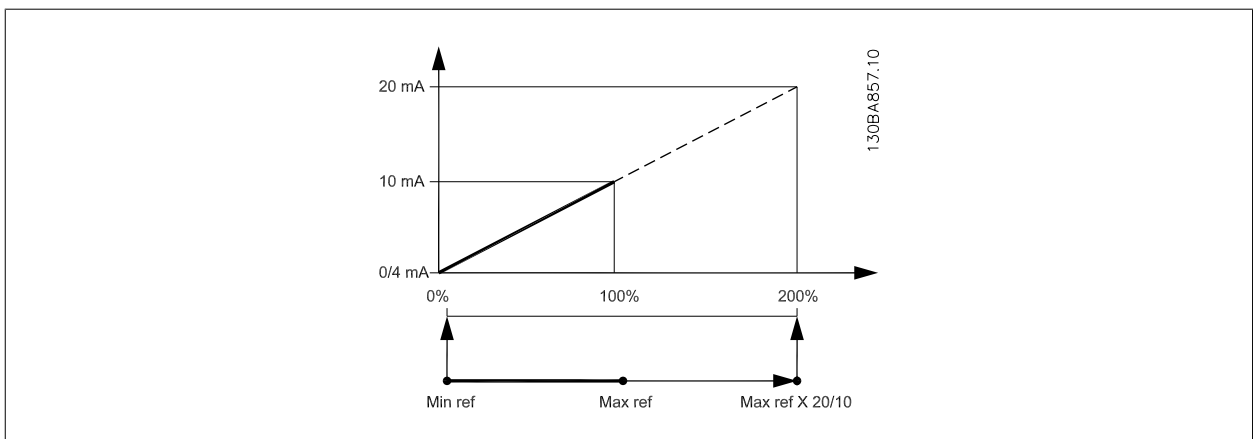

### 14-01 Switching Frequency

**Option:**
**Function:**

Select the inverter switching frequency. Changing the switching frequency can help to reduce acoustic noise from the motor.

**NB!**

The output frequency value of the frequency converter must never exceed 1/10 of the switching frequency. When the motor is running, adjust the switching frequency in par.14-01 *Switching Frequency* until the motor is as noiseless as possible. See also par. 14-00 *Switching Pattern* and the section *Derating*.

[0]	1.0 kHz
[1]	1.5 kHz
[2]	2.0 kHz
[3]	2.5 kHz
[4]	3.0 kHz
[5]	3.5 kHz
[6]	4.0 kHz
[7] *	5.0 kHz
[8]	6.0 kHz
[9]	7.0 kHz
[10]	8.0 kHz
[11]	10.0 kHz
[12]	12.0 kHz
[13]	14.0 kHz
[14]	16.0 kHz

### 20-00 Feedback 1 Source

**Option:**
**Function:**

Up to three different feedback signals can be used to provide the feedback signal for the frequency converter's PID Controller.

This parameter defines which input will be used as the source of the first feedback signal.

Analog input X30/11 and Analog input X30/12 refer to inputs on the optional General Purpose I/O board.

[0]	No function	
[1]	Analog input 53	
[2] *	Analog input 54	
[3]	Pulse input 29	
[4]	Pulse input 33	
[7]	Analog input X30/11	
[8]	Analog input X30/12	
[9]	Analog Input X42/1	
[10]	Analog Input X42/3	
[11]	Analog Input X42/5	
[100]	Bus feedback 1	
[101]	Bus feedback 2	
[102]	Bus feedback 3	
[104]	Sensorless Flow	Requires set up by MCT10 with sensorless specific plug in.
[105]	Sensorless Pressure	Requires set up by MCT10 with sensorless specific plug in.





**NB!**

If a feedback is not used, its source must be set to *No Function* [0]. Par.20-20 *Feedback Function* determines how the three possible feedbacks will be used by the PID Controller.

**20-01 Feedback 1 Conversion**

**Option:**

**Function:**

This parameter allows a conversion function to be applied to Feedback 1.

[0] \* Linear

*Linear* [0] has no effect on the feedback.

[1] Square root

*Square root* [1] is commonly used when a pressure sensor is used to provide flow feedback ((  $flow \propto \sqrt{pressure}$ )).

[2] Pressure to temperature

*Pressure to temperature* [2] is used in compressor applications to provide temperature feedback using a pressure sensor. The temperature of the refrigerant is calculated using the following formula:

$Temperature = \frac{A2}{(\ln(Pe + 1) - A1)} - A3$  , where A1, A2 and A3 are refrigerant-specific constants. The refrigerant must be selected in par. 20-30 *Refrigerant*. Par.20-21 *Setpoint 1* through par. 20-23 *Setpoint 3* allow the values of A1, A2 and A3 to be entered for a refrigerant that is not listed in par. 20-30 *Refrigerant*.

[3] Pressure to flow

[4] Velocity to flow

**20-03 Feedback 2 Source**

**Option:**

**Function:**

See par.20-00 *Feedback 1 Source* for details.

[0] \* No function

[1] Analog input 53

[2] Analog input 54

[3] Pulse input 29

[4] Pulse input 33

[7] Analog input X30/11

[8] Analog input X30/12

[9] Analog Input X42/1

[10] Analog Input X42/3

[11] Analog Input X42/5

[100] Bus feedback 1

[101] Bus feedback 2

[102] Bus feedback 3

**20-04 Feedback 2 Conversion**

**Option:**

**Function:**

See par.20-01 *Feedback 1 Conversion* for details.

[0] \* Linear

[1] Square root

[2] Pressure to temperature

[3] Pressure to flow

[4] Velocity to flow

### 20-06 Feedback 3 Source

**Option:**
**Function:**

See par.20-00 *Feedback 1 Source* for details.

### 20-07 Feedback 3 Conversion

**Option:**
**Function:**

See par.20-01 *Feedback 1 Conversion* for details.

- [0] \* Linear
- [1] Square root
- [2] Pressure to temperature
- [3] Pressure to flow
- [4] Velocity to flow

### 20-20 Feedback Function

**Option:**
**Function:**

This parameter determines how the three possible feedbacks will be used to control the output frequency of the frequency converter.

- [0] Sum

*Sum* [0] sets up the PID Controller to use the sum of Feedback 1, Feedback 2 and Feedback 3 as the feedback.

**NB!**

Any unused feedbacks must be set to *No Function* in par.20-00 *Feedback 1 Source*, par.20-03 *Feedback 2 Source*, or par. 20-06 *Feedback 3 Source*.

The sum of Setpoint 1 and any other references that are enabled (see par. group 3-1\*) will be used as the PID Controller's set-point reference.

- [1] Difference

*Difference* [1] sets up the PID controller to use the difference between Feedback 1 and Feedback 2 as the feedback. Feedback 3 will not be used with this selection. Only Setpoint 1 will be used. The sum of Setpoint 1 and any other references that are enabled (see par. group 3-1\*) will be used as the PID controller's set-point reference.

- [2] Average

*Average* [2] sets up the PID Controller to use the average of Feedback 1, Feedback 2 and Feedback 3 as the feedback.

**NB!**

Any unused feedbacks must be set to *No Function* in par.20-00 *Feedback 1 Source*, par.20-03 *Feedback 2 Source*, or par. 20-06 *Feedback 3 Source*. The sum of Setpoint 1 and any other references that are enabled (see par. group 3-1\*) will be used as the PID Controller's set-point reference.

- [3] \* Minimum

*Minimum* [3] sets up the PID Controller to compare Feedback 1, Feedback 2 and Feedback 3 and use the lowest value as the feedback.

**NB!**

Any unused feedbacks must be set to *No Function* in par.20-00 *Feedback 1 Source*, par.20-03 *Feedback 2 Source*, or par. 20-06 *Feedback 3 Source*. Only setpoint 1 will be used. The sum of Setpoint 1 and any other references that are enabled (see par. group 3-1\*) will be used as the PID Controller's setpoint reference.

- [4] Maximum

*Maximum* [4] sets up the PID Controller to compare Feedback 1, Feedback 2 and Feedback 3 and use the highest value as the feedback.



**NB!**  
Any unused feedbacks must be set to *No Function* in par.20-00 *Feedback 1 Source*, par.20-03 *Feedback 2 Source*, or par. 20-06 *Feedback 3 Source*.

Only Setpoint 1 will be used. The sum of Setpoint 1 and any other references that are enabled (see par. group 3-1\*) will be used as the PID Controller's setpoint reference.

<p>[5] Multi Setpoint Min</p>	<p><i>Multi-setpoint minimum</i> [5] sets up the PID Controller to calculate the difference between Feedback 1 and Setpoint 1, Feedback 2 and Setpoint 2, and Feedback 3 and Setpoint 3. It will use the feedback/setpoint pair in which the feedback is the farthest below its corresponding setpoint reference. If all feedback signals are above their corresponding setpoints, the PID Controller will use the feedback/setpoint pair in which the difference between the feedback and setpoint is the least.</p>  <p><b>NB!</b> If only two feedback signals are used, the feedback that is not to be used must be set to <i>No Function</i> in par.20-00 <i>Feedback 1 Source</i>, par.20-03 <i>Feedback 2 Source</i> or par. 20-06 <i>Feedback 3 Source</i>. Note that each setpoint reference will be the sum of its respective parameter value (par.20-21 <i>Setpoint 1</i>, par. 20-22 <i>Setpoint 2</i> and par. 20-23 <i>Setpoint 3</i>) and any other references that are enabled (see par. group 3-1*).</p>
-------------------------------	--

<p>[6] Multi Setpoint Max</p>	<p><i>Multi-setpoint maximum</i> [6] sets up the PID Controller to calculate the difference between Feedback 1 and Setpoint 1, Feedback 2 and Setpoint 2, and Feedback 3 and Setpoint 3. It will use the feedback/setpoint pair in which the feedback is farthest above its corresponding setpoint reference. If all feedback signals are below their corresponding setpoints, the PID Controller will use the feedback/setpoint pair in which the difference between the feedback and the setpoint reference is the least.</p>  <p><b>NB!</b> If only two feedback signals are used, the feedback that is not to be used must be set to <i>No Function</i> in par.20-00 <i>Feedback 1 Source</i>, par.20-03 <i>Feedback 2 Source</i> or par. 20-06 <i>Feedback 3 Source</i>. Note that each setpoint reference will be the sum of its respective parameter value (par.20-21 <i>Setpoint 1</i>, par. 20-22 <i>Setpoint 2</i> and par. 20-23 <i>Setpoint 3</i>) and any other references that are enabled (see par. group 3-1*).</p>
-------------------------------	--



**NB!**  
Any unused feedback must be set to "No function" in its Feedback Source parameter: Par.20-00 *Feedback 1 Source*, par.20-03 *Feedback 2 Source* or par. 20-06 *Feedback 3 Source*.

The feedback resulting from the function selected in par.20-20 *Feedback Function* will be used by the PID Controller to control the output frequency of the frequency converter. This feedback can also be shown on the frequency converter's display, be used to control a frequency converter's analog output, and be transmitted over various serial communication protocols.

The frequency converter can be configured to handle multi zone applications. Two different multi zone applications are supported:

- Multi zone, single setpoint
- Multi zone, multi setpoint

The difference between the two is illustrated by the following examples:

**Example 1 – Multi zone, single setpoint**

In an office building, a VAV (variable air volume) IVS 102 system must ensure a minimum pressure at selected VAV boxes. Due to the varying pressure losses in each duct, the pressure at each VAV box cannot be assumed to be the same. The minimum pressure required is the same for all VAV boxes. This control method can be set up by setting par.20-20 *Feedback Function* to option [3], Minimum, and entering the desired pressure in par.20-21 *Setpoint*

1. The PID Controller will increase the speed of the fan if any one feedback is below the setpoint and decrease the speed of the fan if all feedbacks are above the setpoint.

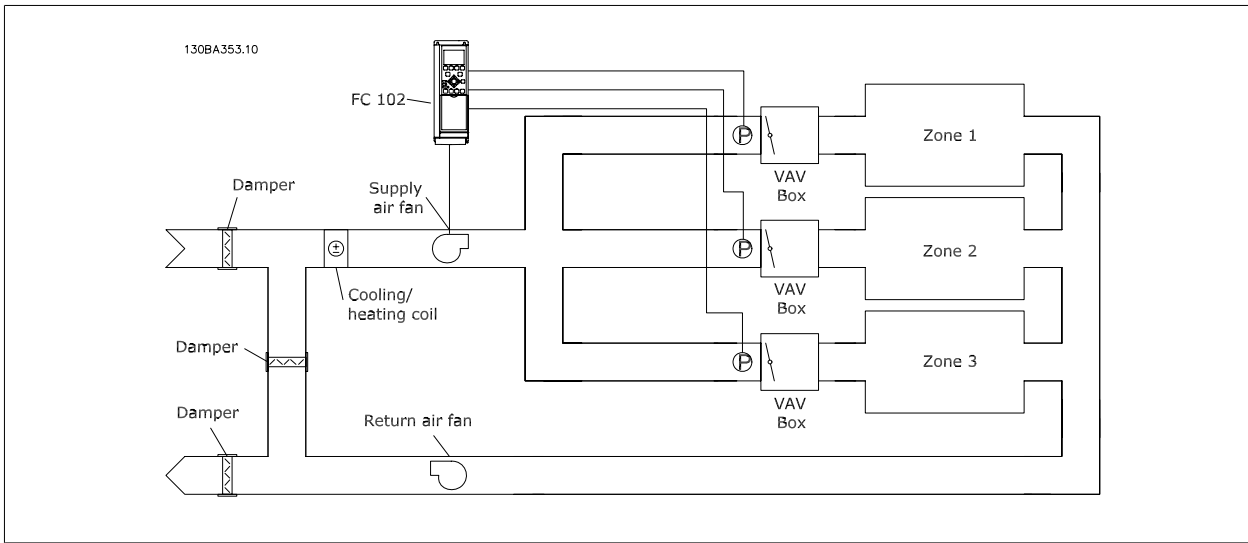

6

**Example 2 – Multi zone, multi setpoint**

The previous example can be used to illustrate the use of multi zone, multi setpoint control. If the zones require different pressures for each VAV box, each setpoint may be specified in par.20-21 *Setpoint 1*, par.20-22 *Setpoint 2* and par. 20-23 *Setpoint 3*. By selecting *Multi setpoint minimum*, [5], in par. 20-20 *Feedback Function*, the PID Controller will increase the speed of the fan if any one of the feedbacks is below its setpoint and decrease the speed of the fan if all feedbacks are above their individual setpoints.

**20-21 Setpoint 1**

**Range:**

0.000 Proc- [-999999.999 - 999999.999 Proc-  
 essCtrlU- essCtrlUnit]  
 nit\*

**Function:**

Setpoint 1 is used in Closed Loop Mode to enter a setpoint reference that is used by the frequency converter's PID Controller. See the description of par.20-20 *Feedback Function*.



**NB!**

Setpoint reference entered here is added to any other references that are enabled (see par. group 3-1\*).

**20-22 Setpoint 2**

**Range:**

0.000 Proc- [-999999.999 - 999999.999 Proc-  
 essCtrlU- essCtrlUnit]  
 nit\*

**Function:**

Setpoint 2 is used in Closed Loop Mode to enter a setpoint reference that may be used by the frequency converter's PID Controller. See the description of *Feedback Function*, par.20-20 *Feedback Function*.



**NB!**

The set-point reference entered here is added to any other references that are enabled (see par. group 3-1\*).

**20-81 PID Normal/ Inverse Control**

**Option:**

[0] \* Normal

**Function:**

*Normal* [0] causes the frequency converter's output frequency to decrease when the feedback is greater than the setpoint reference. This is common for pressure-controlled supply fan and pump applications.

[1] Inverse *Inverse* [1] causes the frequency converter's output frequency to increase when the feedback is greater than the setpoint reference. This is common for temperature-controlled cooling applications, such as cooling towers.

### 20-93 PID Proportional Gain

**Range:** **Function:**

0.50 N/A\* [0.00 - 10.00 N/A]

If (Error x Gain) jumps with a value equal to what is set in par. 20-14 *Maximum Reference/Feedb.* the PID controller will try to change the output speed equal to what is set in par.4-13 *Motor Speed High Limit [RPM]*/par.4-14 *Motor Speed High Limit [Hz]* but in practice of course limited by this setting. The proportional band (error causing output to change from 0-100%) can be calculated by means of the formula:

$$\left( \frac{1}{\text{Proportional Gain}} \right) \times (\text{Max Reference})$$

**NB!**

Always set the desired for par. 20-14 *Maximum Reference/Feedb.* before setting the values for the PID controller in par. group 20-9\*.

### 20-94 PID Integral Time

**Range:** **Function:**

20.00 s\* [0.01 - 10000.00 s]

Over time, the integrator accumulates a contribution to the output from the PID controller as long as there is a deviation between the Reference/Setpoint and feedback signals. The contribution is proportional to the size of the deviation. This ensures that the deviation (error) approaches zero. Quick response on any deviation is obtained when the integral time is set to a low value. Setting it too low, however, may cause the control to become unstable. The value set, is the time needed for the integrator to add the same contribution as the proportional part for a certain deviation. If the value is set to 10,000, the controller will act as a pure proportional controller with a P-band based on the value set in par.20-93 *PID Proportional Gain*. When no deviation is present, the output from the proportional controller will be 0.

### 22-21 Low Power Detection

**Option:** **Function:**

[0] \* Disabled

[1] Enabled If selecting Enabled, the Low Power Detection commissioning must be carried out in order to set the parameters in group 22-3\* for proper operation!

### 22-22 Low Speed Detection

**Option:** **Function:**

[0] \* Disabled

[1] Enabled Select Enabled for detecting when the motor operates with a speed as set in par.4-11 *Motor Speed Low Limit [RPM]* or par.4-12 *Motor Speed Low Limit [Hz]*.

### 22-23 No-Flow Function

Common actions for Low Power Detection and Low Speed Detection (Individual selections not possible).

**Option:** **Function:**

[0] \* Off

[1] Sleep Mode The drive will enter Sleep Mode and stop when a No Flow condition is detected. See parameter group 22-4\* for programming options for Sleep Mode.

[2] Warning The drive will continue to run, but activate a No-Flow Warning [W92]. A drive digital output or a serial communication bus can communicate a warning to other equipment.

[3] Alarm The drive will stop running and activate a No-Flow Alarm [A 92]. A drive digital output or a serial communication bus can communicate an alarm to other equipment.



**NB!**

Do not set par. 14-20 *Reset Mode*, to [13] Infinite auto reset, when par.22-23 *No-Flow Functionis* set to [3] Alarm. Doing so will cause the drive to continuously cycle between running and stopping when a No Flow condition is detected.



**NB!**

If the drive is equipped with a constant speed bypass with an automatic bypass function that starts the bypass if the drive experiences a persistent alarm condition, be sure to disable the bypass's automatic bypass function, if [3] Alarm is selected as the No-Flow Function.

**22-24 No-Flow Delay**

Range:	Function:
10 s* [1 - 600 s]	Set the time Low Power/Low Speed must stay detected to activate signal for actions. If detection disappears before run out of the timer, the timer will be reset.

**22-26 Dry Pump Function**

Select desired action for dry pump operation.

Option:	Function:
[0] * Off	
[1] Warning	The drive will continue to run, but activate a Dry pump warning [W93]. A drive digital output or a serial communication bus can communicate a warning to other equipment.
[2] Alarm	The drive will stop running and activate a Dry pump alarm [A93]. A drive digital output or a serial communication bus can communicate an alarm to other equipment.
[3] Man. Reset Alarm	The drive will stop running and activate a Dry pump alarm [A93]. A drive digital output or a serial communication bus can communicate an alarm to other equipment.



**NB!**

*Low Power Detection* must be Enabled (par.22-21 *Low Power Detection*) and commissioned (using either parameter group 22-3\*, *No Flow Power Tuning*, or par. 22-20 *Low Power Auto Set-up*) in order to use Dry Pump Detection.



**NB!**

Do not set par. 14-20 *Reset Mode*, to [13] Infinite auto reset, when par.22-26 *Dry Pump Function* is set to [2] Alarm. Doing so will cause the drive to continuously cycle between running and stopping when a Dry Pump condition is detected.



**NB!**

If the drive is equipped with a constant speed bypass with an automatic bypass function that starts the bypass if the drive experiences a persistent alarm condition, be sure to disable the bypass's automatic bypass function, if [2] Alarm or [3] Man. Reset Alarm is selected as the Dry Pump Function.

**22-40 Minimum Run Time**

Range:	Function:
10 s* [0 - 600 s]	Set the desired minimum running time for the motor after a start command (digital input or Bus) before entering Sleep Mode.

**22-41 Minimum Sleep Time**

Range:	Function:
10 s* [0 - 600 s]	Set the desired Minimum Time for staying in Sleep Mode. This will override any wake up conditions.

**22-42 Wake-up Speed [RPM]**

**Range:** **Function:**

Application [Application dependant]  
dependent\*

**22-60 Broken Belt Function**

Selects the action to be performed if the Broken Belt condition is detected

**Option:** **Function:**

[0] \* Off

[1] Warning

The drive will continue to run, but activate a Broken Belt Warning [W95]. A drive digital output or a serial communication bus can communicate a warning to other equipment.

[2] Trip

The drive will stop running and activate a Broken Belt alarm [A 95]. A drive digital output or a serial communication bus can communicate an alarm to other equipment.



**NB!**

Do not set par. 14-20 *Reset Mode*, to [13] Infinite auto reset, when par.22-60 *Broken Belt Function* is set to [2] Trip. Doing so will cause the drive to continuously cycle between running and stopping when a broken belt condition is detected.



**NB!**

If the drive is equipped with a constant speed bypass with an automatic bypass function that starts the bypass if the drive experiences a persistent alarm condition, be sure to disable the bypass's automatic bypass function, if [2] Trip is selected as the Broken Belt Function.

**22-61 Broken Belt Torque**

**Range:** **Function:**

10 %\* [0 - 100 %]

Sets the broken belt torque as a percentage of the rated motor torque.

**22-62 Broken Belt Delay**

**Range:** **Function:**

10 s [0 - 600 s]

Sets the time for which the Broken Belt conditions must be active before carrying out the action selected in par.22-60 *Broken Belt Function*.

**22-75 Short Cycle Protection**

**Option:** **Function:**

[0] \* Disabled

Timer set in par.22-76 *Interval between Starts* is disabled.

[1] Enabled

Timer set in par.22-76 *Interval between Starts* is enabled.

**22-76 Interval between Starts**

**Range:** **Function:**

Application [Application dependant]  
dependent\*

**22-77 Minimum Run Time**

**Range:** **Function:**

0 s\* [Application dependant]

Sets the time desired as minimum run time after a normal start command (Start/Jog/Freeze). Any normal stop command will be disregarded until the set time has expired. The timer will start counting following a normal start command (Start/Jog/Freeze).

The timer will be overridden by a Coast (Inverse) or an External Interlock command.



**NB!**  
Does not work in cascade mode.

### 6.1.5 Main Menu mode

Both the GLCP and NLCP provide access to the main menu mode. Select the Main Menu mode by pressing the [Main Menu] key. Illustration 6.2 shows the resulting read-out, which appears on the display of the GLCPLCP.

Lines 2 through 5 on the display show a list of parameter groups which can be chosen by toggling the up and down buttons.

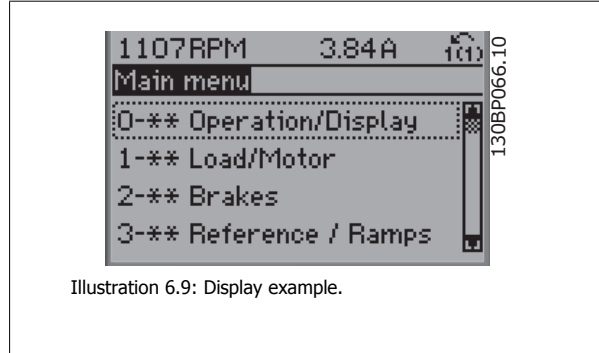

Illustration 6.9: Display example.

Each parameter has a name and number which remain the same regardless of the programming mode. In the Main Menu mode, the parameters are divided into groups. The first digit of the parameter number (from the left) indicates the parameter group number.

All parameters can be changed in the Main Menu. The configuration of the unit (par.1-00 *Configuration Mode*) will determine other parameters available for programming. For example, selecting Closed Loop enables additional parameters related to closed loop operation. Option cards added to the unit enable additional parameters associated with the option device.

### 6.1.6 Parameter selection

In the Main Menu mode, the parameters are divided into groups. Select a parameter group by means of the navigation keys.

The following parameter groups are accessible:

Group no.	Parameter group:
0	Operation/Display
1	Load/Motor
2	Brakes
3	References/Ramps
4	Limits/Warnings
5	Digital In/Out
6	Analog In/Out
8	Comm. and Options
9	Profibus
10	CAN Fieldbus
11	LonWorks
13	Smart Logic
14	Special Functions
15	Drive Information
16	Data Readouts
18	Data Readouts 2
20	Drive Closed Loop
21	Ext. Closed Loop
22	Application Functions
23	Time-based Functions
24	Fire Mode
25	Cascade Controller
26	Analog I/O Option MCB 109

Table 6.3: Parameter groups.

After selecting a parameter group, choose a parameter by means of the navigation keys.

The middle section on the GLCP display shows the parameter number and name as well as the selected parameter value.



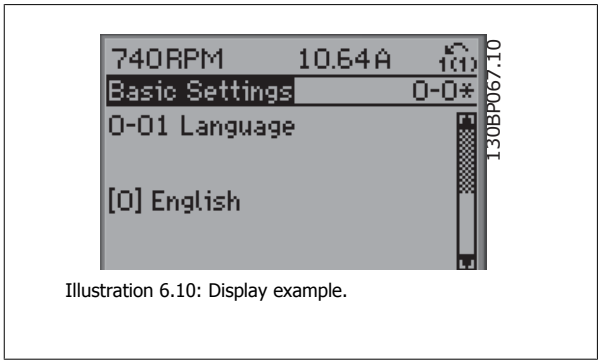

Illustration 6.10: Display example.

### 6.1.7 Changing data

1. Press [Quick Menu] or [Main Menu] key.
2. Use [▲] and [▼] keys to find parameter group to edit.
3. Press [OK] key.
4. Use [▲] and [▼] keys to find parameter to edit.
5. Press [OK] key.
6. Use [▲] and [▼] keys to select correct parameter setting. Or, to move to digits within a number, use keys. Cursor indicates digit selected to change. [▲] key increases the value, [▼] key decreases the value.
7. Press [Cancel] key to disregard change, or press [OK] key to accept change and enter new setting.

### 6.1.8 Changing a text value

If the selected parameter is a text value, change the text value by means of the up/down navigation keys. The up key increases the value, and the down key decreases the value. Place the cursor on the value to be saved and press [OK].

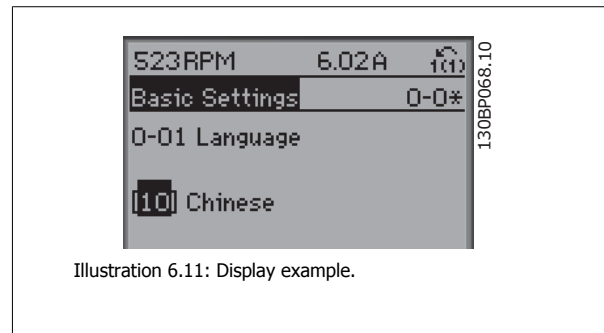

Illustration 6.11: Display example.

### 6.1.9 Changing a group of numeric data values

If the chosen parameter represents a numeric data value, change the chosen data value by means of the [←] and [→] navigation keys as well as the up/down [▲] [▼] navigation keys. Use the [←] and [→] navigation keys to move the cursor horizontally.

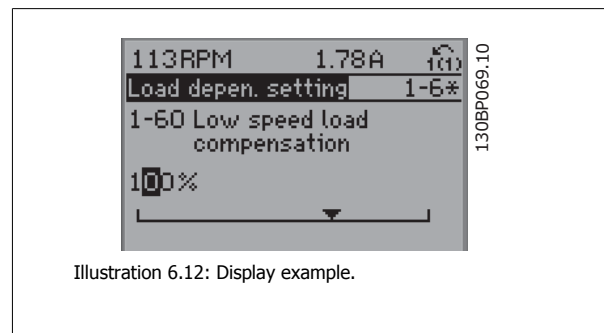

Illustration 6.12: Display example.

Use the up/down navigation keys to change the data value. The up key enlarges the data value, and the down key reduces the data value. Place the cursor on the value to be saved and press [OK].

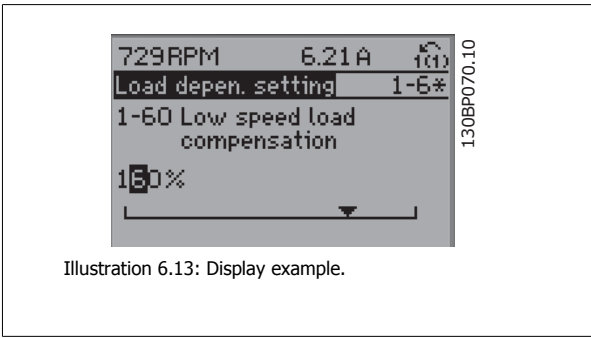

Illustration 6.13: Display example.

### 6.1.10 Changing of data value, Step-by-Step

Certain parameters can be changed step by step or infinitely variably. This applies to par.1-20 *Motor Power [kW]*, par.1-22 *Motor Voltage* and par. 1-23 *Motor Frequency*.

The parameters are changed both as a group of numeric data values and as numeric data values infinitely variably.

### 6.1.11 Read-out and programming of indexed parameters

Parameters are indexed when placed in a rolling stack.

Par. 15-30 *Alarm Log: Error Code* to par. 15-32 *Alarm Log: Time* contain a fault log which can be read out. Choose a parameter, press [OK], and use the up/down navigation keys to scroll through the value log.

Use par.3-10 *Preset Reference* as another example:

Choose the parameter, press [OK], and use the up/down navigation keys keys to scroll through the indexed values. To change the parameter value, select the indexed value and press [OK]. Change the value by using the up/down keys. Press [OK] to accept the new setting. Press [Cancel] to abort. Press [Back] to leave the parameter.

## 6.2 Parameter lists

### 6.2.1 Main Menu Structure

Parameters for the frequency converter are grouped into various parameter groups for easy selection of the correct parameters for optimized operation of the frequency converter.

The vast majority of IVS 102 applications can be programmed using the Quick Menu button and selecting the parameters under Quick Setup and Function Setups.

Descriptions and default settings of parameters may be found under the section Parameter Lists at the back of this manual.

0-xx Operation/Display	10-xx CAN Fieldbus
1-xx Load/Motor	11-xx LonWorks
2-xx Brakes	13-xx Smart Logic Controller
3-xx Reference/Ramps	14-xx Special Functions
4-xx Limits/ Warnings	15-xx FC Information
5-xx Digital In/Out	16-xx Data Readouts
6-xx Analog In/Out	18-xx Info & Readouts
8-xx Comm. and Options	20-xx FC Closed Loop
9-xx Profibus	21-xx Ext. Closed Loop
	22-xx Application Functions
	23-xx Time Based Functions
	24-xx Application Functions 2
	25-xx Cascade Controller
	26-xx Analog I/O Option MCB 109

### 6.2.2 0-\*\* Operation and Display

Par. No. #	Parameter description	Default value	4-set-up	Change during operation	Conversion index	Type
<b>0-0* Basic Settings</b>						
0-01	Language	[0] English	1 set-up	TRUE	-	Uint8
0-02	Motor Speed Unit	[1] Hz	2 set-ups	FALSE	-	Uint8
0-03	Regional Settings	[0] International	2 set-ups	FALSE	-	Uint8
0-04	Operating State at Power-up	[0] Resume	All set-ups	TRUE	-	Uint8
0-05	Local Mode Unit	[0] As Motor Speed Unit	2 set-ups	FALSE	-	Uint8
<b>0-1* Set-up Operations</b>						
0-10	Active Set-up	[1] Set-up 1	1 set-up	TRUE	-	Uint8
0-11	Programming Set-up	[9] Active Set-up	All set-ups	TRUE	-	Uint8
0-12	This Set-up Linked to	[0] Not linked	All set-ups	FALSE	-	Uint8
0-13	Readout: Linked Set-ups	0 N/A	All set-ups	FALSE	0	Uint16
0-14	Readout: Prog. Set-ups / Channel	0 N/A	All set-ups	TRUE	0	Int32
<b>0-2* LCP Display</b>						
0-20	Display Line 1.1 Small	1602	All set-ups	TRUE	-	Uint16
0-21	Display Line 1.2 Small	1614	All set-ups	TRUE	-	Uint16
0-22	Display Line 1.3 Small	1610	All set-ups	TRUE	-	Uint16
0-23	Display Line 2 Large	1613	All set-ups	TRUE	-	Uint16
0-24	Display Line 3 Large	1502	All set-ups	TRUE	-	Uint16
0-25	My Personal Menu	SR	1 set-up	TRUE	0	Uint16
<b>0-3* LCP Custom Readout</b>						
0-30	Custom Readout Unit	[1] %	All set-ups	TRUE	-	Uint8
0-31	Custom Readout Min Value	SR	All set-ups	TRUE	-2	Int32
0-32	Custom Readout Max Value	100.00 CustomReadoutUnit	All set-ups	TRUE	-2	Int32
0-37	Display Text 1	0 N/A	1 set-up	TRUE	0	VisStr[25]
0-38	Display Text 2	0 N/A	1 set-up	TRUE	0	VisStr[25]
0-39	Display Text 3	0 N/A	1 set-up	TRUE	0	VisStr[25]
<b>0-4* LCP Keypad</b>						
0-40	[Hand on] Key on LCP	[1] Enabled	All set-ups	TRUE	-	Uint8
0-41	[Off] Key on LCP	[1] Enabled	All set-ups	TRUE	-	Uint8
0-42	[Auto on] Key on LCP	[1] Enabled	All set-ups	TRUE	-	Uint8
0-43	[Reset] Key on LCP	[1] Enabled	All set-ups	TRUE	-	Uint8
0-44	[Off/Reset] Key on LCP	[1] Enabled	All set-ups	TRUE	-	Uint8
0-45	[Drive Bypass] Key on LCP	[1] Enabled	All set-ups	TRUE	-	Uint8



Par. No. #	Parameter description	Default value	4-set-up	Change during operation	Conversion index	Type
<b>0-5* Copy/Save</b>						
0-50	LCP Copy	[0] No copy	All set-ups	FALSE	-	UInt8
0-51	Set-up Copy	[0] No copy	All set-ups	FALSE	-	UInt8
<b>0-6* Password</b>						
0-60	Main Menu Password	100 N/A	1 set-up	TRUE	0	Int16
0-61	Access to Main Menu w/o Password	[0] Full access	1 set-up	TRUE	-	UInt8
0-65	Personal Menu Password	200 N/A	1 set-up	TRUE	0	Int16
0-66	Access to Personal Menu w/o Password	[0] Full access	1 set-up	TRUE	-	UInt8
<b>0-7* Clock Settings</b>						
0-70	Date and Time	SR	All set-ups	TRUE	0	TimeOfDay
0-71	Date Format	null	1 set-up	TRUE	-	UInt8
0-72	Time Format	null	1 set-up	TRUE	-	UInt8
0-74	DST/Summertime	[0] Off	1 set-up	TRUE	-	UInt8
0-76	DST/Summertime Start	SR	1 set-up	TRUE	0	TimeOfDay
0-77	DST/Summertime End	SR	1 set-up	TRUE	0	TimeOfDay
0-79	Clock Fault	null	1 set-up	TRUE	-	UInt8
0-81	Working Days	null	1 set-up	TRUE	-	UInt8
0-82	Additional Working Days	SR	1 set-up	TRUE	0	TimeOfDay
0-83	Additional Non-Working Days	SR	1 set-up	TRUE	0	TimeOfDay
0-89	Date and Time Readout	0 N/A	All set-ups	TRUE	0	VisStr[25]

### 6.2.3 1-\*\* Load / Motor

Par. No. #	Parameter description	Default value	4-set-up	Change during operation	Conversion index	Type
<b>1-0* General Settings</b>						
1-00	Configuration Mode	null	All set-ups	TRUE	-	Uint8
1-03	Torque Characteristics	[3] Auto Energy Optim. VT	All set-ups	TRUE	-	Uint8
<b>1-2* Motor Data</b>						
1-20	Motor Power [kW]	SR	All set-ups	FALSE	1	Uint32
1-21	Motor Power [HP]	SR	All set-ups	FALSE	-2	Uint32
1-22	Motor Voltage	SR	All set-ups	FALSE	0	Uint16
1-23	Motor Frequency	SR	All set-ups	FALSE	0	Uint16
1-24	Motor Current	SR	All set-ups	FALSE	-2	Uint32
1-25	Motor Nominal Speed	SR	All set-ups	FALSE	67	Uint16
1-28	Motor Rotation Check	[0] Off	All set-ups	FALSE	-	Uint8
1-29	Automatic Motor Adaptation (AMA)	[0] Off	All set-ups	FALSE	-	Uint8
<b>1-3* Adv. Motor Data</b>						
1-30	Stator Resistance (Rs)	SR	All set-ups	FALSE	-4	Uint32
1-31	Rotor Resistance (Rr)	SR	All set-ups	FALSE	-4	Uint32
1-35	Main Reactance (Xh)	SR	All set-ups	FALSE	-4	Uint32
1-36	Iron Loss Resistance (Rfe)	SR	All set-ups	FALSE	-3	Uint32
1-39	Motor Poles	SR	All set-ups	FALSE	0	Uint8
<b>1-5* Load Indep. Setting</b>						
1-50	Motor Magnetisation at Zero Speed	100 %	All set-ups	TRUE	0	Uint16
1-51	Min Speed Normal Magnetising [RPM]	SR	All set-ups	TRUE	67	Uint16
1-52	Min Speed Normal Magnetising [Hz]	SR	All set-ups	TRUE	-1	Uint16
<b>1-6* Load Depen. Setting</b>						
1-60	Low Speed Load Compensation	100 %	All set-ups	TRUE	0	Int16
1-61	High Speed Load Compensation	100 %	All set-ups	TRUE	0	Int16
1-62	Slip Compensation	0 %	All set-ups	TRUE	0	Int16
1-63	Slip Compensation Time Constant	SR	All set-ups	TRUE	-2	Uint16
1-64	Resonance Dampening	100 %	All set-ups	TRUE	0	Uint16
1-65	Resonance Dampening Time Constant	5 ms	All set-ups	TRUE	-3	Uint8
<b>1-7* Start Adjustments</b>						
1-71	Start Delay	0.0 s	All set-ups	TRUE	-1	Uint16
1-73	Flying Start	[0] Disabled	All set-ups	TRUE	-	Uint8
<b>1-8* Stop Adjustments</b>						
1-80	Function at Stop	[0] Coast	All set-ups	TRUE	-	Uint8
1-81	Min Speed for Function at Stop [RPM]	SR	All set-ups	TRUE	67	Uint16
1-82	Min Speed for Function at Stop [Hz]	SR	All set-ups	TRUE	-1	Uint16
1-86	Trip Speed Low [RPM]	0 RPM	All set-ups	TRUE	67	Uint16
1-87	Trip Speed Low [Hz]	0.0 Hz	All set-ups	TRUE	-1	Uint16
<b>1-9* Motor Temperature</b>						
1-90	Motor Thermal Protection	[4] ETR trip 1	All set-ups	TRUE	-	Uint8
1-91	Motor External Fan	[0] No	All set-ups	TRUE	-	Uint16
1-93	Thermistor Source	[0] None	All set-ups	TRUE	-	Uint8



### 6.2.4 2-\*\* Brakes

Par. No. #	Parameter description	Default value	4-set-up	Change during operation	Conversion index	Type
<b>2-0* DC-Brake</b>						
2-00	DC Hold/Preheat Current	50 %	All set-ups	TRUE	0	Uint8
2-01	DC Brake Current	50 %	All set-ups	TRUE	0	Uint16
2-02	DC Braking Time	10.0 s	All set-ups	TRUE	-1	Uint16
2-03	DC Brake Cut In Speed [RPM]	SR	All set-ups	TRUE	67	Uint16
2-04	DC Brake Cut In Speed [Hz]	SR	All set-ups	TRUE	-1	Uint16
<b>2-1* Brake Energy Funct.</b>						
2-10	Brake Function	[0] Off	All set-ups	TRUE	-	Uint8
2-11	Brake Resistor (ohm)	SR	All set-ups	TRUE	-2	Uint32
2-12	Brake Power Limit (kW)	SR	All set-ups	TRUE	0	Uint32
2-13	Brake Power Monitoring	[0] Off	All set-ups	TRUE	-	Uint8
2-15	Brake Check	[0] Off	All set-ups	TRUE	-	Uint8
2-16	AC brake Max. Current	100.0 %	All set-ups	TRUE	-1	Uint32
2-17	Over-voltage Control	[2] Enabled	All set-ups	TRUE	-	Uint8

6

### 6.2.5 3-\*\* Reference / Ramps

Par. No. #	Parameter description	Default value	4-set-up	Change during operation	Conversion index	Type
<b>3-0* Reference Limits</b>						
3-02	Minimum Reference	SR	All set-ups	TRUE	-3	Int32
3-03	Maximum Reference	SR	All set-ups	TRUE	-3	Int32
3-04	Reference Function	null	All set-ups	TRUE	-	Uint8
<b>3-1* References</b>						
3-10	Preset Reference	0.00 %	All set-ups	TRUE	-2	Int16
3-11	Jog Speed [Hz]	SR	All set-ups	TRUE	-1	Uint16
3-13	Reference Site	[0] Linked to Hand / Auto	All set-ups	TRUE	-	Uint8
3-14	Preset Relative Reference	0.00 %	All set-ups	TRUE	-2	Int32
3-15	Reference 1 Source	[1] Analog input 53	All set-ups	TRUE	-	Uint8
3-16	Reference 2 Source	[20] Digital pot.meter	All set-ups	TRUE	-	Uint8
3-17	Reference 3 Source	[0] No function	All set-ups	TRUE	-	Uint8
3-19	Jog Speed [RPM]	SR	All set-ups	TRUE	67	Uint16
<b>3-4* Ramp 1</b>						
3-41	Ramp 1 Ramp Up Time	SR	All set-ups	TRUE	-2	Uint32
3-42	Ramp 1 Ramp Down Time	SR	All set-ups	TRUE	-2	Uint32
<b>3-5* Ramp 2</b>						
3-51	Ramp 2 Ramp Up Time	SR	All set-ups	TRUE	-2	Uint32
3-52	Ramp 2 Ramp Down Time	SR	All set-ups	TRUE	-2	Uint32
<b>3-8* Other Ramps</b>						
3-80	Jog Ramp Time	SR	All set-ups	TRUE	-2	Uint32
3-81	Quick Stop Ramp Time	SR	2 set-ups	TRUE	-2	Uint32
<b>3-9* Digital Pot.Meter</b>						
3-90	Step Size	0.10 %	All set-ups	TRUE	-2	Uint16
3-91	Ramp Time	1.00 s	All set-ups	TRUE	-2	Uint32
3-92	Power Restore	[0] Off	All set-ups	TRUE	-	Uint8
3-93	Maximum Limit	100 %	All set-ups	TRUE	0	Int16
3-94	Minimum Limit	0 %	All set-ups	TRUE	0	Int16
3-95	Ramp Delay	SR	All set-ups	TRUE	-3	TimD

### 6.2.6 4-\*\* Limits / Warnings

Par. No. #	Parameter description	Default value	4-set-up	Change during operation	Conversion index	Type
<b>4-1* Motor Limits</b>						
4-10	Motor Speed Direction	[2] Both directions	All set-ups	FALSE	-	Uint8
4-11	Motor Speed Low Limit [RPM]	SR	All set-ups	TRUE	67	Uint16
4-12	Motor Speed Low Limit [Hz]	SR	All set-ups	TRUE	-1	Uint16
4-13	Motor Speed High Limit [RPM]	SR	All set-ups	TRUE	67	Uint16
4-14	Motor Speed High Limit [Hz]	SR	All set-ups	TRUE	-1	Uint16
4-16	Torque Limit Motor Mode	SR	All set-ups	TRUE	-1	Uint16
4-17	Torque Limit Generator Mode	100.0 %	All set-ups	TRUE	-1	Uint16
4-18	Current Limit	SR	All set-ups	TRUE	-1	Uint32
4-19	Max Output Frequency	SR	All set-ups	FALSE	-1	Uint16
<b>4-5* Adj. Warnings</b>						
4-50	Warning Current Low	0.00 A	All set-ups	TRUE	-2	Uint32
4-51	Warning Current High	ImaxVLT (P1637)	All set-ups	TRUE	-2	Uint32
4-52	Warning Speed Low	0 RPM	All set-ups	TRUE	67	Uint16
4-53	Warning Speed High	outputSpeedHighLimit (P413)	All set-ups	TRUE	67	Uint16
4-54	Warning Reference Low	-999999.999 N/A	All set-ups	TRUE	-3	Int32
4-55	Warning Reference High	999999.999 N/A	All set-ups	TRUE	-3	Int32
4-56	Warning Feedback Low	-999999.999 ProcessCtrlUnit	All set-ups	TRUE	-3	Int32
4-57	Warning Feedback High	999999.999 ProcessCtrlUnit	All set-ups	TRUE	-3	Int32
4-58	Missing Motor Phase Function	[2] Trip 1000 ms	All set-ups	TRUE	-	Uint8
<b>4-6* Speed Bypass</b>						
4-60	Bypass Speed From [RPM]	SR	All set-ups	TRUE	67	Uint16
4-61	Bypass Speed From [Hz]	SR	All set-ups	TRUE	-1	Uint16
4-62	Bypass Speed To [RPM]	SR	All set-ups	TRUE	67	Uint16
4-63	Bypass Speed To [Hz]	SR	All set-ups	TRUE	-1	Uint16
4-64	Semi-Auto Bypass Set-up	[0] Off	All set-ups	FALSE	-	Uint8



## 6.2.7 5-\*\*-\*\* Digital In / Out

Par. No. #	Parameter description	Default value	4-set-up	Change during operation	Conversion index	Type
<b>5-0* Digital I/O mode</b>						
5-00	Digital I/O Mode	[0] PNP - Active at 24V	All set-ups	FALSE	-	Uint8
5-01	Terminal 27 Mode	[0] Input	All set-ups	TRUE	-	Uint8
5-02	Terminal 29 Mode	[0] Input	All set-ups	TRUE	-	Uint8
<b>5-1* Digital Inputs</b>						
5-10	Terminal 18 Digital Input	[8] Start	All set-ups	TRUE	-	Uint8
5-11	Terminal 19 Digital Input	[0] No operation	All set-ups	TRUE	-	Uint8
5-12	Terminal 27 Digital Input	null	All set-ups	TRUE	-	Uint8
5-13	Terminal 29 Digital Input	[14] Jog	All set-ups	TRUE	-	Uint8
5-14	Terminal 32 Digital Input	[0] No operation	All set-ups	TRUE	-	Uint8
5-15	Terminal 33 Digital Input	[0] No operation	All set-ups	TRUE	-	Uint8
5-16	Terminal X30/2 Digital Input	[0] No operation	All set-ups	TRUE	-	Uint8
5-17	Terminal X30/3 Digital Input	[0] No operation	All set-ups	TRUE	-	Uint8
5-18	Terminal X30/4 Digital Input	[0] No operation	All set-ups	TRUE	-	Uint8
<b>5-3* Digital Outputs</b>						
5-30	Terminal 27 Digital Output	[0] No operation	All set-ups	TRUE	-	Uint8
5-31	Terminal 29 Digital Output	[0] No operation	All set-ups	TRUE	-	Uint8
5-32	Term X30/6 Digi Out (MCB 101)	[0] No operation	All set-ups	TRUE	-	Uint8
5-33	Term X30/7 Digi Out (MCB 101)	[0] No operation	All set-ups	TRUE	-	Uint8
<b>5-4* Relays</b>						
5-40	Function Relay	null	All set-ups	TRUE	-	Uint8
5-41	On Delay, Relay	0.01 s	All set-ups	TRUE	-2	Uint16
5-42	Off Delay, Relay	0.01 s	All set-ups	TRUE	-2	Uint16
<b>5-5* Pulse Input</b>						
5-50	Term. 29 Low Frequency	100 Hz	All set-ups	TRUE	0	Uint32
5-51	Term. 29 High Frequency	100 Hz	All set-ups	TRUE	0	Uint32
5-52	Term. 29 Low Ref./Feedb. Value	0.000 N/A	All set-ups	TRUE	-3	Int32
5-53	Term. 29 High Ref./Feedb. Value	100.000 N/A	All set-ups	TRUE	-3	Int32
5-54	Pulse Filter Time Constant #29	100 ms	All set-ups	FALSE	-3	Uint16
5-55	Term. 33 Low Frequency	100 Hz	All set-ups	TRUE	0	Uint32
5-56	Term. 33 High Frequency	100 Hz	All set-ups	TRUE	0	Uint32
5-57	Term. 33 Low Ref./Feedb. Value	0.000 N/A	All set-ups	TRUE	-3	Int32
5-58	Term. 33 High Ref./Feedb. Value	100.000 N/A	All set-ups	TRUE	-3	Int32
5-59	Pulse Filter Time Constant #33	100 ms	All set-ups	FALSE	-3	Uint16
<b>5-6* Pulse Output</b>						
5-60	Terminal 27 Pulse Output Variable	[0] No operation	All set-ups	TRUE	-	Uint8
5-62	Pulse Output Max Freq #27	5000 Hz	All set-ups	TRUE	0	Uint32
5-63	Terminal 29 Pulse Output Variable	[0] No operation	All set-ups	TRUE	-	Uint8
5-65	Pulse Output Max Freq #29	5000 Hz	All set-ups	TRUE	0	Uint32
5-66	Terminal X30/6 Pulse Output Variable	[0] No operation	All set-ups	TRUE	-	Uint8
5-68	Pulse Output Max Freq #X30/6	5000 Hz	All set-ups	TRUE	0	Uint32
<b>5-9* Bus Controlled</b>						
5-90	Digital & Relay Bus Control	0 N/A	All set-ups	TRUE	0	Uint32
5-93	Pulse Out #27 Bus Control	0.00 %	All set-ups	TRUE	-2	N2
5-94	Pulse Out #27 Timeout Preset	0.00 %	1 set-up	TRUE	-2	Uint16
5-95	Pulse Out #29 Bus Control	0.00 %	All set-ups	TRUE	-2	N2
5-96	Pulse Out #29 Timeout Preset	0.00 %	1 set-up	TRUE	-2	Uint16
5-97	Pulse Out #X30/6 Bus Control	0.00 %	All set-ups	TRUE	-2	N2
5-98	Pulse Out #X30/6 Timeout Preset	0.00 %	1 set-up	TRUE	-2	Uint16



### 6.2.8 6-\*\* Analog In / Out

Par. No. #	Parameter description	Default value	4-set-up	Change during operation	Conversion index	Type
<b>6-0* Analog I/O Mode</b>						
6-00	Live Zero Timeout Time	10 s	All set-ups	TRUE	0	Uint8
6-01	Live Zero Timeout Function	[0] Off	All set-ups	TRUE	-	Uint8
6-02	Fire Mode Live Zero Timeout Function	[0] Off	All set-ups	TRUE	-	Uint8
<b>6-1* Analog Input 53</b>						
6-10	Terminal 53 Low Voltage	0.07 V	All set-ups	TRUE	-2	Int16
6-11	Terminal 53 High Voltage	10.00 V	All set-ups	TRUE	-2	Int16
6-12	Terminal 53 Low Current	4.00 mA	All set-ups	TRUE	-5	Int16
6-13	Terminal 53 High Current	20.00 mA	All set-ups	TRUE	-5	Int16
6-14	Terminal 53 Low Ref./Feedb. Value	0.000 N/A	All set-ups	TRUE	-3	Int32
6-15	Terminal 53 High Ref./Feedb. Value	SR	All set-ups	TRUE	-3	Int32
6-16	Terminal 53 Filter Time Constant	0.001 s	All set-ups	TRUE	-3	Uint16
6-17	Terminal 53 Live Zero	[1] Enabled	All set-ups	TRUE	-	Uint8
<b>6-2* Analog Input 54</b>						
6-20	Terminal 54 Low Voltage	0.07 V	All set-ups	TRUE	-2	Int16
6-21	Terminal 54 High Voltage	10.00 V	All set-ups	TRUE	-2	Int16
6-22	Terminal 54 Low Current	4.00 mA	All set-ups	TRUE	-5	Int16
6-23	Terminal 54 High Current	20.00 mA	All set-ups	TRUE	-5	Int16
6-24	Terminal 54 Low Ref./Feedb. Value	0.000 N/A	All set-ups	TRUE	-3	Int32
6-25	Terminal 54 High Ref./Feedb. Value	100.000 N/A	All set-ups	TRUE	-3	Int32
6-26	Terminal 54 Filter Time Constant	0.001 s	All set-ups	TRUE	-3	Uint16
6-27	Terminal 54 Live Zero	[1] Enabled	All set-ups	TRUE	-	Uint8
<b>6-3* Analog Input X30/11</b>						
6-30	Terminal X30/11 Low Voltage	0.07 V	All set-ups	TRUE	-2	Int16
6-31	Terminal X30/11 High Voltage	10.00 V	All set-ups	TRUE	-2	Int16
6-34	Term. X30/11 Low Ref./Feedb. Value	0.000 N/A	All set-ups	TRUE	-3	Int32
6-35	Term. X30/11 High Ref./Feedb. Value	100.000 N/A	All set-ups	TRUE	-3	Int32
6-36	Term. X30/11 Filter Time Constant	0.001 s	All set-ups	TRUE	-3	Uint16
6-37	Term. X30/11 Live Zero	[1] Enabled	All set-ups	TRUE	-	Uint8
<b>6-4* Analog Input X30/12</b>						
6-40	Terminal X30/12 Low Voltage	0.07 V	All set-ups	TRUE	-2	Int16
6-41	Terminal X30/12 High Voltage	10.00 V	All set-ups	TRUE	-2	Int16
6-44	Term. X30/12 Low Ref./Feedb. Value	0.000 N/A	All set-ups	TRUE	-3	Int32
6-45	Term. X30/12 High Ref./Feedb. Value	100.000 N/A	All set-ups	TRUE	-3	Int32
6-46	Term. X30/12 Filter Time Constant	0.001 s	All set-ups	TRUE	-3	Uint16
6-47	Term. X30/12 Live Zero	[1] Enabled	All set-ups	TRUE	-	Uint8
<b>6-5* Analog Output 42</b>						
6-50	Terminal 42 Output	null	All set-ups	TRUE	-	Uint8
6-51	Terminal 42 Output Min Scale	0.00 %	All set-ups	TRUE	-2	Int16
6-52	Terminal 42 Output Max Scale	100.00 %	All set-ups	TRUE	-2	Int16
6-53	Terminal 42 Output Bus Control	0.00 %	All set-ups	TRUE	-2	N2
6-54	Terminal 42 Output Timeout Preset	0.00 %	1 set-up	TRUE	-2	Uint16
<b>6-6* Analog Output X30/8</b>						
6-60	Terminal X30/8 Output	[0] No operation	All set-ups	TRUE	-	Uint8
6-61	Terminal X30/8 Min. Scale	0.00 %	All set-ups	TRUE	-2	Int16
6-62	Terminal X30/8 Max. Scale	100.00 %	All set-ups	TRUE	-2	Int16
6-63	Terminal X30/8 Output Bus Control	0.00 %	All set-ups	TRUE	-2	N2
6-64	Terminal X30/8 Output Timeout Preset	0.00 %	1 set-up	TRUE	-2	Uint16



## 6.2.9 8- \*\* Communication and Options

Par. No. #	Parameter description	Default value	4-set-up	Change during operation	Conversion index	Type
<b>8-0* General Settings</b>						
8-01	Control Site	null	All set-ups	TRUE	-	Uint8
8-02	Control Source	null	All set-ups	TRUE	-	Uint8
8-03	Control Timeout Time	SR	1 set-up	TRUE	-1	Uint32
8-04	Control Timeout Function	[0] Off	1 set-up	TRUE	-	Uint8
8-05	End-of-Timeout Function	[1] Resume set-up	1 set-up	TRUE	-	Uint8
8-06	Reset Control Timeout	[0] Do not reset	All set-ups	TRUE	-	Uint8
8-07	Diagnosis Trigger	[0] Disable	2 set-ups	TRUE	-	Uint8
<b>8-1* Control Settings</b>						
8-10	Control Profile	[0] FC profile	All set-ups	FALSE	-	Uint8
8-13	Configurable Status Word STW	[1] Profile Default	All set-ups	TRUE	-	Uint8
<b>8-3* FC Port Settings</b>						
8-30	Protocol	null	1 set-up	TRUE	-	Uint8
8-31	Address	SR	1 set-up	TRUE	0	Uint8
8-32	Baud Rate	null	1 set-up	TRUE	-	Uint8
8-33	Parity / Stop Bits	null	1 set-up	TRUE	-	Uint8
8-35	Minimum Response Delay	SR	1 set-up	TRUE	-3	Uint16
8-36	Maximum Response Delay	SR	1 set-up	TRUE	-3	Uint16
8-37	Maximum Inter-Char Delay	SR	1 set-up	TRUE	-5	Uint16
<b>8-4* FC MC protocol set</b>						
8-40	Telegram Selection	[1] Standard telegram 1	2 set-ups	TRUE	-	Uint8
<b>8-5* Digital/Bus</b>						
8-50	Coasting Select	[3] Logic OR	All set-ups	TRUE	-	Uint8
8-52	DC Brake Select	[3] Logic OR	All set-ups	TRUE	-	Uint8
8-53	Start Select	[3] Logic OR	All set-ups	TRUE	-	Uint8
8-54	Reversing Select	null	All set-ups	TRUE	-	Uint8
8-55	Set-up Select	[3] Logic OR	All set-ups	TRUE	-	Uint8
8-56	Preset Reference Select	[3] Logic OR	All set-ups	TRUE	-	Uint8
<b>8-7* BACnet</b>						
8-70	BACnet Device Instance	1 N/A	1 set-up	TRUE	0	Uint32
8-72	MS/TP Max Masters	127 N/A	1 set-up	TRUE	0	Uint8
8-73	MS/TP Max Info Frames	1 N/A	1 set-up	TRUE	0	Uint16
8-74	"I-Am" Service	[0] Send at power-up	1 set-up	TRUE	-	Uint8
8-75	Initialisation Password	SR	1 set-up	TRUE	0	VisStr[20]
<b>8-8* FC Port Diagnostics</b>						
8-80	Bus Message Count	0 N/A	All set-ups	TRUE	0	Uint32
8-81	Bus Error Count	0 N/A	All set-ups	TRUE	0	Uint32
8-82	Slave Messages Rcvd	0 N/A	All set-ups	TRUE	0	Uint32
8-83	Slave Error Count	0 N/A	All set-ups	TRUE	0	Uint32
8-84	Slave Messages Sent	0 N/A	All set-ups	TRUE	0	Uint32
8-85	Slave Timeout Errors	0 N/A	All set-ups	TRUE	0	Uint32
8-89	Diagnostics Count	0 N/A	1 set-up	TRUE	0	Int32
<b>8-9* Bus Jog / Feedback</b>						
8-90	Bus Jog 1 Speed	100 RPM	All set-ups	TRUE	67	Uint16
8-91	Bus Jog 2 Speed	200 RPM	All set-ups	TRUE	67	Uint16
8-94	Bus Feedback 1	0 N/A	1 set-up	TRUE	0	N2
8-95	Bus Feedback 2	0 N/A	1 set-up	TRUE	0	N2
8-96	Bus Feedback 3	0 N/A	1 set-up	TRUE	0	N2

**6.2.10 9-\*\* Profibus**

Par. No. #	Parameter description	Default value	4-set-up	Change during operation	Conversion index	Type
9-00	Setpoint	0 N/A	All set-ups	TRUE	0	Uint16
9-07	Actual Value	0 N/A	All set-ups	FALSE	0	Uint16
9-15	PCD Write Configuration	SR	2 set-ups	TRUE	-	Uint16
9-16	PCD Read Configuration	SR	2 set-ups	TRUE	-	Uint16
9-18	Node Address	126 N/A	1 set-up	TRUE	0	Uint8
9-22	Telegram Selection	[108] PPO 8	1 set-up	TRUE	-	Uint8
9-23	Parameters for Signals	0	All set-ups	TRUE	-	Uint16
9-27	Parameter Edit	[1] Enabled	2 set-ups	FALSE	-	Uint16
9-28	Process Control	[1] Enable cyclic master	2 set-ups	FALSE	-	Uint8
9-44	Fault Message Counter	0 N/A	All set-ups	TRUE	0	Uint16
9-45	Fault Code	0 N/A	All set-ups	TRUE	0	Uint16
9-47	Fault Number	0 N/A	All set-ups	TRUE	0	Uint16
9-52	Fault Situation Counter	0 N/A	All set-ups	TRUE	0	Uint16
9-53	Profibus Warning Word	0 N/A	All set-ups	TRUE	0	V2
9-63	Actual Baud Rate	[255] No baudrate found	All set-ups	TRUE	-	Uint8
9-64	Device Identification	0 N/A	All set-ups	TRUE	0	Uint16
9-65	Profile Number	0 N/A	All set-ups	TRUE	0	OctStr[2]
9-67	Control Word 1	0 N/A	All set-ups	TRUE	0	V2
9-68	Status Word 1	0 N/A	All set-ups	TRUE	0	V2
9-71	Profibus Save Data Values	[0] Off	All set-ups	TRUE	-	Uint8
9-72	ProfibusDriveReset	[0] No action	1 set-up	FALSE	-	Uint8
9-80	Defined Parameters (1)	0 N/A	All set-ups	FALSE	0	Uint16
9-81	Defined Parameters (2)	0 N/A	All set-ups	FALSE	0	Uint16
9-82	Defined Parameters (3)	0 N/A	All set-ups	FALSE	0	Uint16
9-83	Defined Parameters (4)	0 N/A	All set-ups	FALSE	0	Uint16
9-84	Defined Parameters (5)	0 N/A	All set-ups	FALSE	0	Uint16
9-90	Changed Parameters (1)	0 N/A	All set-ups	FALSE	0	Uint16
9-91	Changed Parameters (2)	0 N/A	All set-ups	FALSE	0	Uint16
9-92	Changed Parameters (3)	0 N/A	All set-ups	FALSE	0	Uint16
9-93	Changed Parameters (4)	0 N/A	All set-ups	FALSE	0	Uint16
9-94	Changed Parameters (5)	0 N/A	All set-ups	FALSE	0	Uint16



### 6.2.11 10-\*\* CAN Fieldbus

Par. No. #	Parameter description	Default value	4-set-up	Change during operation	Conversion index	Type
<b>10-0* Common Settings</b>						
10-00	CAN Protocol	null	2 set-ups	FALSE	-	Uint8
10-01	Baud Rate Select	null	2 set-ups	TRUE	-	Uint8
10-02	MAC ID	SR	2 set-ups	TRUE	0	Uint8
10-05	Readout Transmit Error Counter	0 N/A	All set-ups	TRUE	0	Uint8
10-06	Readout Receive Error Counter	0 N/A	All set-ups	TRUE	0	Uint8
10-07	Readout Bus Off Counter	0 N/A	All set-ups	TRUE	0	Uint8
<b>10-1* DeviceNet</b>						
10-10	Process Data Type Selection	null	All set-ups	TRUE	-	Uint8
10-11	Process Data Config Write	SR	2 set-ups	TRUE	-	Uint16
10-12	Process Data Config Read	SR	2 set-ups	TRUE	-	Uint16
10-13	Warning Parameter	0 N/A	All set-ups	TRUE	0	Uint16
10-14	Net Reference	[0] Off	2 set-ups	TRUE	-	Uint8
10-15	Net Control	[0] Off	2 set-ups	TRUE	-	Uint8
<b>10-2* COS Filters</b>						
10-20	COS Filter 1	0 N/A	All set-ups	FALSE	0	Uint16
10-21	COS Filter 2	0 N/A	All set-ups	FALSE	0	Uint16
10-22	COS Filter 3	0 N/A	All set-ups	FALSE	0	Uint16
10-23	COS Filter 4	0 N/A	All set-ups	FALSE	0	Uint16
<b>10-3* Parameter Access</b>						
10-30	Array Index	0 N/A	2 set-ups	TRUE	0	Uint8
10-31	Store Data Values	[0] Off	All set-ups	TRUE	-	Uint8
10-32	Devicenet Revision	0 N/A	All set-ups	TRUE	0	Uint16
10-33	Store Always	[0] Off	1 set-up	TRUE	-	Uint8
10-34	DeviceNet Product Code	120 N/A	1 set-up	TRUE	0	Uint16
10-39	Devicenet F Parameters	0 N/A	All set-ups	TRUE	0	Uint32

### 6.2.12 11-\*\* LonWorks

Par. No. #	Parameter description	Default value	4-set-up	Change during operation	Conversion index	Type
<b>11-0* LonWorks ID</b>						
11-00	Neuron ID	0 N/A	All set-ups	TRUE	0	OctStr[6]
<b>11-1* LON Functions</b>						
11-10	Drive Profile	[0] VSD profile	All set-ups	TRUE	-	Uint8
11-15	LON Warning Word	0 N/A	All set-ups	TRUE	0	Uint16
11-17	XIF Revision	0 N/A	All set-ups	TRUE	0	VisStr[5]
11-18	LonWorks Revision	0 N/A	All set-ups	TRUE	0	VisStr[5]
<b>11-2* LON Param. Access</b>						
11-21	Store Data Values	[0] Off	All set-ups	TRUE	-	Uint8

### 6.2.13 13-\*\* Smart Logic Controller

Par. No. #	Parameter description	Default value (SR=Size related)	4-set-up	Change during operation	Conversion index	Type
<b>13-0* SLC Settings</b>						
13-00	SL Controller Mode	null	2 set-ups	TRUE	-	Uint8
13-01	Start Event	null	2 set-ups	TRUE	-	Uint8
13-02	Stop Event	null	2 set-ups	TRUE	-	Uint8
13-03	Reset SLC	[0] Do not reset SLC	All set-ups	TRUE	-	Uint8
<b>13-1* Comparators</b>						
13-10	Comparator Operand	null	2 set-ups	TRUE	-	Uint8
13-11	Comparator Operator	null	2 set-ups	TRUE	-	Uint8
13-12	Comparator Value	SR	2 set-ups	TRUE	-3	Int32
<b>13-2* Timers</b>						
13-20	SL Controller Timer	SR	1 set-up	TRUE	-3	TimD
<b>13-4* Logic Rules</b>						
13-40	Logic Rule Boolean 1	null	2 set-ups	TRUE	-	Uint8
13-41	Logic Rule Operator 1	null	2 set-ups	TRUE	-	Uint8
13-42	Logic Rule Boolean 2	null	2 set-ups	TRUE	-	Uint8
13-43	Logic Rule Operator 2	null	2 set-ups	TRUE	-	Uint8
13-44	Logic Rule Boolean 3	null	2 set-ups	TRUE	-	Uint8
<b>13-5* States</b>						
13-51	SL Controller Event	null	2 set-ups	TRUE	-	Uint8
13-52	SL Controller Action	null	2 set-ups	TRUE	-	Uint8

## 6.2.14 14-\*\* Special Functions

Par. No. #	Parameter description	Default value	4-set-up	Change during operation	Conversion index	Type
<b>14-0* Inverter Switching</b>						
14-00	Switching Pattern	null	All set-ups	TRUE	-	Uint8
14-01	Switching Frequency	null	All set-ups	TRUE	-	Uint8
14-03	Overmodulation	[1] On	All set-ups	FALSE	-	Uint8
14-04	PWM Random	[0] Off	All set-ups	TRUE	-	Uint8
<b>14-1* Mains On/Off</b>						
14-10	Mains Failure	[0] No function	All set-ups	FALSE	-	Uint8
14-11	Mains Voltage at Mains Fault	SR	All set-ups	TRUE	0	Uint16
14-12	Function at Mains Imbalance	[0] Trip	All set-ups	TRUE	-	Uint8
<b>14-2* Reset Functions</b>						
14-20	Reset Mode	null	All set-ups	TRUE	-	Uint8
14-21	Automatic Restart Time	10 s	All set-ups	TRUE	0	Uint16
14-22	Operation Mode	[0] Normal operation	All set-ups	TRUE	-	Uint8
14-23	Typecode Setting	null	2 set-ups	FALSE	-	Uint8
14-25	Trip Delay at Torque Limit	60 s	All set-ups	TRUE	0	Uint8
14-26	Trip Delay at Inverter Fault	SR	All set-ups	TRUE	0	Uint8
14-28	Production Settings	[0] No action	All set-ups	TRUE	-	Uint8
14-29	Service Code	0 N/A	All set-ups	TRUE	0	Int32
<b>14-3* Current Limit Ctrl.</b>						
14-30	Current Lim Ctrl, Proportional Gain	100 %	All set-ups	FALSE	0	Uint16
14-31	Current Lim Ctrl, Integration Time	0.020 s	All set-ups	FALSE	-3	Uint16
14-32	Current Lim Ctrl, Filter Time	26.0 ms	All set-ups	TRUE	-4	Uint16
<b>14-4* Energy Optimising</b>						
14-40	VT Level	66 %	All set-ups	FALSE	0	Uint8
14-41	AEO Minimum Magnetisation	SR	All set-ups	TRUE	0	Uint8
14-42	Minimum AEO Frequency	10 Hz	All set-ups	TRUE	0	Uint8
14-43	Motor Cosphi	SR	All set-ups	TRUE	-2	Uint16
<b>14-5* Environment</b>						
14-50	RFI Filter	[1] On	1 set-up	FALSE	-	Uint8
14-52	Fan Control	[0] Auto	All set-ups	TRUE	-	Uint8
14-53	Fan Monitor	[1] Warning	All set-ups	TRUE	-	Uint8
14-55	Output Filter	[0] No Filter	1 set-up	FALSE	-	Uint8
14-59	Actual Number of Inverter Units	SR	1 set-up	FALSE	0	Uint8
<b>14-6* Auto Derate</b>						
14-60	Function at Over Temperature	[0] Trip	All set-ups	TRUE	-	Uint8
14-61	Function at Inverter Overload	[0] Trip	All set-ups	TRUE	-	Uint8
14-62	Inv. Overload Derate Current	95 %	All set-ups	TRUE	0	Uint16

### 6.2.15 15-\*\* FC Information

Par. No. #	Parameter description	Default value	4-set-up	Change during operation	Conversion index	Type
<b>15-0* Operating Data</b>						
15-00	Operating Hours	0 h	All set-ups	FALSE	74	Uint32
15-01	Running Hours	0 h	All set-ups	FALSE	74	Uint32
15-02	kWh Counter	0 kWh	All set-ups	FALSE	75	Uint32
15-03	Power Up's	0 N/A	All set-ups	FALSE	0	Uint32
15-04	Over Temp's	0 N/A	All set-ups	FALSE	0	Uint16
15-05	Over Volt's	0 N/A	All set-ups	FALSE	0	Uint16
15-06	Reset kWh Counter	[0] Do not reset	All set-ups	TRUE	-	Uint8
15-07	Reset Running Hours Counter	[0] Do not reset	All set-ups	TRUE	-	Uint8
15-08	Number of Starts	0 N/A	All set-ups	FALSE	0	Uint32
<b>15-1* Data Log Settings</b>						
15-10	Logging Source	0	2 set-ups	TRUE	-	Uint16
15-11	Logging Interval	SR	2 set-ups	TRUE	-3	TimD
15-12	Trigger Event	[0] False	1 set-up	TRUE	-	Uint8
15-13	Logging Mode	[0] Log always	2 set-ups	TRUE	-	Uint8
15-14	Samples Before Trigger	50 N/A	2 set-ups	TRUE	0	Uint8
<b>15-2* Historic Log</b>						
15-20	Historic Log: Event	0 N/A	All set-ups	FALSE	0	Uint8
15-21	Historic Log: Value	0 N/A	All set-ups	FALSE	0	Uint32
15-22	Historic Log: Time	0 ms	All set-ups	FALSE	-3	Uint32
15-23	Historic Log: Date and Time	SR	All set-ups	FALSE	0	TimeOfDay
<b>15-3* Alarm Log</b>						
15-30	Alarm Log: Error Code	0 N/A	All set-ups	FALSE	0	Uint8
15-31	Alarm Log: Value	0 N/A	All set-ups	FALSE	0	Int16
15-32	Alarm Log: Time	0 s	All set-ups	FALSE	0	Uint32
15-33	Alarm Log: Date and Time	SR	All set-ups	FALSE	0	TimeOfDay
<b>15-4* Drive Identification</b>						
15-40	FC Type	0 N/A	All set-ups	FALSE	0	VisStr[6]
15-41	Power Section	0 N/A	All set-ups	FALSE	0	VisStr[20]
15-42	Voltage	0 N/A	All set-ups	FALSE	0	VisStr[20]
15-43	Software Version	0 N/A	All set-ups	FALSE	0	VisStr[5]
15-44	Ordered Typecode String	0 N/A	All set-ups	FALSE	0	VisStr[40]
15-45	Actual Typecode String	0 N/A	All set-ups	FALSE	0	VisStr[40]
15-46	Frequency Converter Ordering No	0 N/A	All set-ups	FALSE	0	VisStr[8]
15-47	Power Card Ordering No	0 N/A	All set-ups	FALSE	0	VisStr[8]
15-48	LCP Id No	0 N/A	All set-ups	FALSE	0	VisStr[20]
15-49	SW ID Control Card	0 N/A	All set-ups	FALSE	0	VisStr[20]
15-50	SW ID Power Card	0 N/A	All set-ups	FALSE	0	VisStr[20]
15-51	Frequency Converter Serial Number	0 N/A	All set-ups	FALSE	0	VisStr[10]
15-53	Power Card Serial Number	0 N/A	All set-ups	FALSE	0	VisStr[19]



Par. No. #	Parameter description	Default value	4-set-up	Change during operation	Conversion index	Type
<b>15-6* Option Ident</b>						
15-60	Option Mounted	0 N/A	All set-ups	FALSE	0	VisStr[30]
15-61	Option SW Version	0 N/A	All set-ups	FALSE	0	VisStr[20]
15-62	Option Ordering No	0 N/A	All set-ups	FALSE	0	VisStr[8]
15-63	Option Serial No	0 N/A	All set-ups	FALSE	0	VisStr[18]
15-70	Option in Slot A	0 N/A	All set-ups	FALSE	0	VisStr[30]
15-71	Slot A Option SW Version	0 N/A	All set-ups	FALSE	0	VisStr[20]
15-72	Option in Slot B	0 N/A	All set-ups	FALSE	0	VisStr[30]
15-73	Slot B Option SW Version	0 N/A	All set-ups	FALSE	0	VisStr[20]
15-74	Option in Slot C0	0 N/A	All set-ups	FALSE	0	VisStr[30]
15-75	Slot C0 Option SW Version	0 N/A	All set-ups	FALSE	0	VisStr[20]
15-76	Option in Slot C1	0 N/A	All set-ups	FALSE	0	VisStr[30]
15-77	Slot C1 Option SW Version	0 N/A	All set-ups	FALSE	0	VisStr[20]
<b>15-9* Parameter Info</b>						
15-92	Defined Parameters	0 N/A	All set-ups	FALSE	0	Uint16
15-93	Modified Parameters	0 N/A	All set-ups	FALSE	0	Uint16
15-98	Drive Identification	0 N/A	All set-ups	FALSE	0	VisStr[40]
15-99	Parameter Metadata	0 N/A	All set-ups	FALSE	0	Uint16



### 6.2.16 16-\*\* Data Readouts

Par. No. #	Parameter description	Default value	4-set-up	Change during operation	Conversion index	Type
<b>16-0* General Status</b>						
16-00	Control Word	0 N/A	All set-ups	FALSE	0	V2
16-01	Reference [Unit]	0.000 ReferenceFeedbackUnit	All set-ups	FALSE	-3	Int32
16-02	Reference [%]	0.0 %	All set-ups	FALSE	-1	Int16
16-03	Status Word	0 N/A	All set-ups	FALSE	0	V2
16-05	Main Actual Value [%]	0.00 %	All set-ups	FALSE	-2	N2
16-09	Custom Readout	0.00 CustomReadoutUnit	All set-ups	FALSE	-2	Int32
<b>16-1* Motor Status</b>						
16-10	Power [kW]	0.00 kW	All set-ups	FALSE	1	Int32
16-11	Power [hp]	0.00 hp	All set-ups	FALSE	-2	Int32
16-12	Motor Voltage	0.0 V	All set-ups	FALSE	-1	Uint16
16-13	Frequency	0.0 Hz	All set-ups	FALSE	-1	Uint16
16-14	Motor Current	0.00 A	All set-ups	FALSE	-2	Int32
16-15	Frequency [%]	0.00 %	All set-ups	FALSE	-2	N2
16-16	Torque [Nm]	0.0 Nm	All set-ups	FALSE	-1	Int32
16-17	Speed [RPM]	0 RPM	All set-ups	FALSE	67	Int32
16-18	Motor Thermal	0 %	All set-ups	FALSE	0	Uint8
16-22	Torque [%]	0 %	All set-ups	FALSE	0	Int16
16-26	Power Filtered [kW]	0.000 kW	All set-ups	FALSE	0	Int32
16-27	Power Filtered [hp]	0.000 hp	All set-ups	FALSE	-3	Int32
<b>16-3* Drive Status</b>						
16-30	DC Link Voltage	0 V	All set-ups	FALSE	0	Uint16
16-32	Brake Energy /s	0.000 kW	All set-ups	FALSE	0	Uint32
16-33	Brake Energy /2 min	0.000 kW	All set-ups	FALSE	0	Uint32
16-34	Heatsink Temp.	0 °C	All set-ups	FALSE	100	Uint8
16-35	Inverter Thermal	0 %	All set-ups	FALSE	0	Uint8
16-36	Inv. Nom. Current	SR	All set-ups	FALSE	-2	Uint32
16-37	Inv. Max. Current	SR	All set-ups	FALSE	-2	Uint32
16-38	SL Controller State	0 N/A	All set-ups	FALSE	0	Uint8
16-39	Control Card Temp.	0 °C	All set-ups	FALSE	100	Uint8
16-40	Logging Buffer Full	[0] No	All set-ups	TRUE	-	Uint8
16-49	Current Fault Source	0 N/A	All set-ups	TRUE	0	Uint8
<b>16-5* Ref. &amp; Feedb.</b>						
16-50	External Reference	0.0 N/A	All set-ups	FALSE	-1	Int16
16-52	Feedback [Unit]	0.000 ProcessCtrlUnit	All set-ups	FALSE	-3	Int32
16-53	Digi Pot Reference	0.00 N/A	All set-ups	FALSE	-2	Int16
16-54	Feedback 1 [Unit]	0.000 ProcessCtrlUnit	All set-ups	FALSE	-3	Int32
16-55	Feedback 2 [Unit]	0.000 ProcessCtrlUnit	All set-ups	FALSE	-3	Int32
16-56	Feedback 3 [Unit]	0.000 ProcessCtrlUnit	All set-ups	FALSE	-3	Int32
16-58	PID Output [%]	0.0 %	All set-ups	TRUE	-1	Int16

Par. No. #	Parameter description	Default value	4-set-up	Change during operation	Conversion index	Type
<b>16-6* Inputs &amp; Outputs</b>						
16-60	Digital Input	0 N/A	All set-ups	FALSE	0	UInt16
16-61	Terminal 53 Switch Setting	[0] Current	All set-ups	FALSE	-	UInt8
16-62	Analog Input 53	0.000 N/A	All set-ups	FALSE	-3	Int32
16-63	Terminal 54 Switch Setting	[0] Current	All set-ups	FALSE	-	UInt8
16-64	Analog Input 54	0.000 N/A	All set-ups	FALSE	-3	Int32
16-65	Analog Output 42 [mA]	0.000 N/A	All set-ups	FALSE	-3	Int16
16-66	Digital Output [bin]	0 N/A	All set-ups	FALSE	0	Int16
16-67	Pulse Input #29 [Hz]	0 N/A	All set-ups	FALSE	0	Int32
16-68	Pulse Input #33 [Hz]	0 N/A	All set-ups	FALSE	0	Int32
16-69	Pulse Output #27 [Hz]	0 N/A	All set-ups	FALSE	0	Int32
16-70	Pulse Output #29 [Hz]	0 N/A	All set-ups	FALSE	0	Int32
16-71	Relay Output [bin]	0 N/A	All set-ups	FALSE	0	Int16
16-72	Counter A	0 N/A	All set-ups	TRUE	0	Int32
16-73	Counter B	0 N/A	All set-ups	TRUE	0	Int32
16-75	Analog In X30/11	0.000 N/A	All set-ups	FALSE	-3	Int32
16-76	Analog In X30/12	0.000 N/A	All set-ups	FALSE	-3	Int32
16-77	Analog Out X30/8 [mA]	0.000 N/A	All set-ups	FALSE	-3	Int16
<b>16-8* Fieldbus &amp; FC Port</b>						
16-80	Fieldbus CTW 1	0 N/A	All set-ups	FALSE	0	V2
16-82	Fieldbus REF 1	0 N/A	All set-ups	FALSE	0	N2
16-84	Comm. Option STW	0 N/A	All set-ups	FALSE	0	V2
16-85	FC Port CTW 1	0 N/A	All set-ups	FALSE	0	V2
16-86	FC Port REF 1	0 N/A	All set-ups	FALSE	0	N2
<b>16-9* Diagnosis Readouts</b>						
16-90	Alarm Word	0 N/A	All set-ups	FALSE	0	UInt32
16-91	Alarm Word 2	0 N/A	All set-ups	FALSE	0	UInt32
16-92	Warning Word	0 N/A	All set-ups	FALSE	0	UInt32
16-93	Warning Word 2	0 N/A	All set-ups	FALSE	0	UInt32
16-94	Ext. Status Word	0 N/A	All set-ups	FALSE	0	UInt32
16-95	Ext. Status Word 2	0 N/A	All set-ups	FALSE	0	UInt32
16-96	Maintenance Word	0 N/A	All set-ups	FALSE	0	UInt32

**6.2.17 18-\*\* Info & Readouts**

Par. No. #	Parameter description	Default value	4-set-up	Change during operation	Conversion index	Type
<b>18-0* Maintenance Log</b>						
18-00	Maintenance Log: Item	0 N/A	All set-ups	FALSE	0	UInt8
18-01	Maintenance Log: Action	0 N/A	All set-ups	FALSE	0	UInt8
18-02	Maintenance Log: Time	0 s	All set-ups	FALSE	0	UInt32
18-03	Maintenance Log: Date and Time	SR	All set-ups	FALSE	0	TimeOfDay
<b>18-1* Fire Mode Log</b>						
18-10	Fire Mode Log: Event	0 N/A	All set-ups	FALSE	0	UInt8
18-11	Fire Mode Log: Time	0 s	All set-ups	FALSE	0	UInt32
18-12	Fire Mode Log: Date and Time	SR	All set-ups	FALSE	0	TimeOfDay
<b>18-3* Inputs &amp; Outputs</b>						
18-30	Analog Input X42/1	0.000 N/A	All set-ups	FALSE	-3	Int32
18-31	Analog Input X42/3	0.000 N/A	All set-ups	FALSE	-3	Int32
18-32	Analog Input X42/5	0.000 N/A	All set-ups	FALSE	-3	Int32
18-33	Analog Out X42/7 [V]	0.000 N/A	All set-ups	FALSE	-3	Int16
18-34	Analog Out X42/9 [V]	0.000 N/A	All set-ups	FALSE	-3	Int16
18-35	Analog Out X42/11 [V]	0.000 N/A	All set-ups	FALSE	-3	Int16
<b>18-5* Ref. &amp; Feedb.</b>						
18-50	Sensorless Readout [unit]	0.000 SensorlessUnit	All set-ups	FALSE	-3	Int32



## 6.2.18 20-\*\* FC Closed Loop

Par. No. #	Parameter description	Default value	4-set-up	Change during operation	Conversion index	Type
<b>20-0* Feedback</b>						
20-00	Feedback 1 Source	[2] Analog input 54	All set-ups	TRUE	-	UInt8
20-01	Feedback 1 Conversion	[0] Linear	All set-ups	FALSE	-	UInt8
20-02	Feedback 1 Source Unit	null	All set-ups	TRUE	-	UInt8
20-03	Feedback 2 Source	[0] No function	All set-ups	TRUE	-	UInt8
20-04	Feedback 2 Conversion	[0] Linear	All set-ups	FALSE	-	UInt8
20-05	Feedback 2 Source Unit	null	All set-ups	TRUE	-	UInt8
20-06	Feedback 3 Source	[0] No function	All set-ups	TRUE	-	UInt8
20-07	Feedback 3 Conversion	[0] Linear	All set-ups	FALSE	-	UInt8
20-08	Feedback 3 Source Unit	null	All set-ups	TRUE	-	UInt8
20-12	Reference/Feedback Unit	null	All set-ups	TRUE	-	UInt8
20-13	Minimum Reference/Feedb.	0.000 ProcessCtrlUnit	All set-ups	TRUE	-3	Int32
20-14	Maximum Reference/Feedb.	100.000 ProcessCtrlUnit	All set-ups	TRUE	-3	Int32
<b>20-2* Feedback/Setpoint</b>						
20-20	Feedback Function	[3] Minimum	All set-ups	TRUE	-	UInt8
20-21	Setpoint 1	0.000 ProcessCtrlUnit	All set-ups	TRUE	-3	Int32
20-22	Setpoint 2	0.000 ProcessCtrlUnit	All set-ups	TRUE	-3	Int32
20-23	Setpoint 3	0.000 ProcessCtrlUnit	All set-ups	TRUE	-3	Int32
<b>20-3* Feedb. Adv. Conv.</b>						
20-30	Refrigerant	[0] R22	All set-ups	TRUE	-	UInt8
20-31	User Defined Refrigerant A1	10.0000 N/A	All set-ups	TRUE	-4	UInt32
20-32	User Defined Refrigerant A2	-2250.00 N/A	All set-ups	TRUE	-2	Int32
20-33	User Defined Refrigerant A3	250.000 N/A	All set-ups	TRUE	-3	UInt32
20-34	Fan 1 Area [m2]	0.500 m2	All set-ups	TRUE	-3	UInt32
20-35	Fan 1 Area [in2]	750 in2	All set-ups	TRUE	0	UInt32
20-36	Fan 2 Area [m2]	0.500 m2	All set-ups	TRUE	-3	UInt32
20-37	Fan 2 Area [in2]	750 in2	All set-ups	TRUE	0	UInt32
20-38	Air Density Factor [%]	100 %	All set-ups	TRUE	0	UInt32
<b>20-6* Sensorless</b>						
20-60	Sensorless Unit	null	All set-ups	TRUE	-	UInt8
20-69	Sensorless Information	0 N/A	All set-ups	TRUE	0	VisStr[25]
<b>20-7* PID Autotuning</b>						
20-70	Closed Loop Type	[0] Auto	2 set-ups	TRUE	-	UInt8
20-71	PID Performance	[0] Normal	2 set-ups	TRUE	-	UInt8
20-72	PID Output Change	0.10 N/A	2 set-ups	TRUE	-2	UInt16
20-73	Minimum Feedback Level	-999999.000 ProcessCtrlUnit	2 set-ups	TRUE	-3	Int32
20-74	Maximum Feedback Level	999999.000 ProcessCtrlUnit	2 set-ups	TRUE	-3	Int32
20-79	PID Autotuning	[0] Disabled	All set-ups	TRUE	-	UInt8
<b>20-8* PID Basic Settings</b>						
20-81	PID Normal/ Inverse Control	[0] Normal	All set-ups	TRUE	-	UInt8
20-82	PID Start Speed [RPM]	SR	All set-ups	TRUE	67	UInt16
20-83	PID Start Speed [Hz]	SR	All set-ups	TRUE	-1	UInt16
20-84	On Reference Bandwidth	5 %	All set-ups	TRUE	0	UInt8
<b>20-9* PID Controller</b>						
20-91	PID Anti Windup	[1] On	All set-ups	TRUE	-	UInt8
20-93	PID Proportional Gain	0.50 N/A	All set-ups	TRUE	-2	UInt16
20-94	PID Integral Time	20.00 s	All set-ups	TRUE	-2	UInt32
20-95	PID Differentiation Time	0.00 s	All set-ups	TRUE	-2	UInt16
20-96	PID Diff. Gain Limit	5.0 N/A	All set-ups	TRUE	-1	UInt16

### 6.2.19 21-\*\* Ext. Closed Loop

Par. No. #	Parameter description	Default value	4-set-up	Change during operation	Conversion index	Type
<b>21-0* Ext. CL Autotuning</b>						
21-00	Closed Loop Type	[0] Auto	2 set-ups	TRUE	-	UInt8
21-01	PID Performance	[0] Normal	2 set-ups	TRUE	-	UInt8
21-02	PID Output Change	0.10 N/A	2 set-ups	TRUE	-2	UInt16
21-03	Minimum Feedback Level	-999999.000 N/A	2 set-ups	TRUE	-3	Int32
21-04	Maximum Feedback Level	999999.000 N/A	2 set-ups	TRUE	-3	Int32
21-09	PID Autotuning	[0] Disabled	All set-ups	TRUE	-	UInt8
<b>21-1* Ext. CL 1 Ref./Fb.</b>						
21-10	Ext. 1 Ref./Feedback Unit	[1] %	All set-ups	TRUE	-	UInt8
21-11	Ext. 1 Minimum Reference	0.000 ExtPID1Unit	All set-ups	TRUE	-3	Int32
21-12	Ext. 1 Maximum Reference	100.000 ExtPID1Unit	All set-ups	TRUE	-3	Int32
21-13	Ext. 1 Reference Source	[0] No function	All set-ups	TRUE	-	UInt8
21-14	Ext. 1 Feedback Source	[0] No function	All set-ups	TRUE	-	UInt8
21-15	Ext. 1 Setpoint	0.000 ExtPID1Unit	All set-ups	TRUE	-3	Int32
21-17	Ext. 1 Reference [Unit]	0.000 ExtPID1Unit	All set-ups	TRUE	-3	Int32
21-18	Ext. 1 Feedback [Unit]	0.000 ExtPID1Unit	All set-ups	TRUE	-3	Int32
21-19	Ext. 1 Output [%]	0 %	All set-ups	TRUE	0	Int32
<b>21-2* Ext. CL 1 PID</b>						
21-20	Ext. 1 Normal/Inverse Control	[0] Normal	All set-ups	TRUE	-	UInt8
21-21	Ext. 1 Proportional Gain	0.01 N/A	All set-ups	TRUE	-2	UInt16
21-22	Ext. 1 Integral Time	10000.00 s	All set-ups	TRUE	-2	UInt32
21-23	Ext. 1 Differentiation Time	0.00 s	All set-ups	TRUE	-2	UInt16
21-24	Ext. 1 Dif. Gain Limit	5.0 N/A	All set-ups	TRUE	-1	UInt16
<b>21-3* Ext. CL 2 Ref./Fb.</b>						
21-30	Ext. 2 Ref./Feedback Unit	[1] %	All set-ups	TRUE	-	UInt8
21-31	Ext. 2 Minimum Reference	0.000 ExtPID2Unit	All set-ups	TRUE	-3	Int32
21-32	Ext. 2 Maximum Reference	100.000 ExtPID2Unit	All set-ups	TRUE	-3	Int32
21-33	Ext. 2 Reference Source	[0] No function	All set-ups	TRUE	-	UInt8
21-34	Ext. 2 Feedback Source	[0] No function	All set-ups	TRUE	-	UInt8
21-35	Ext. 2 Setpoint	0.000 ExtPID2Unit	All set-ups	TRUE	-3	Int32
21-37	Ext. 2 Reference [Unit]	0.000 ExtPID2Unit	All set-ups	TRUE	-3	Int32
21-38	Ext. 2 Feedback [Unit]	0.000 ExtPID2Unit	All set-ups	TRUE	-3	Int32
21-39	Ext. 2 Output [%]	0 %	All set-ups	TRUE	0	Int32
<b>21-4* Ext. CL 2 PID</b>						
21-40	Ext. 2 Normal/Inverse Control	[0] Normal	All set-ups	TRUE	-	UInt8
21-41	Ext. 2 Proportional Gain	0.01 N/A	All set-ups	TRUE	-2	UInt16
21-42	Ext. 2 Integral Time	10000.00 s	All set-ups	TRUE	-2	UInt32
21-43	Ext. 2 Differentiation Time	0.00 s	All set-ups	TRUE	-2	UInt16
21-44	Ext. 2 Dif. Gain Limit	5.0 N/A	All set-ups	TRUE	-1	UInt16

Par. No. #	Parameter description	Default value	4-set-up	Change during operation	Conversion index	Type
<b>21-5* Ext. CL 3 Ref./Fb.</b>						
21-50	Ext. 3 Ref./Feedback Unit	[1] %	All set-ups	TRUE	-	Uint8
21-51	Ext. 3 Minimum Reference	0.000 ExtPID3Unit	All set-ups	TRUE	-3	Int32
21-52	Ext. 3 Maximum Reference	100.000 ExtPID3Unit	All set-ups	TRUE	-3	Int32
21-53	Ext. 3 Reference Source	[0] No function	All set-ups	TRUE	-	Uint8
21-54	Ext. 3 Feedback Source	[0] No function	All set-ups	TRUE	-	Uint8
21-55	Ext. 3 Setpoint	0.000 ExtPID3Unit	All set-ups	TRUE	-3	Int32
21-57	Ext. 3 Reference [Unit]	0.000 ExtPID3Unit	All set-ups	TRUE	-3	Int32
21-58	Ext. 3 Feedback [Unit]	0.000 ExtPID3Unit	All set-ups	TRUE	-3	Int32
21-59	Ext. 3 Output [%]	0 %	All set-ups	TRUE	0	Int32
<b>21-6* Ext. CL 3 PID</b>						
21-60	Ext. 3 Normal/Inverse Control	[0] Normal	All set-ups	TRUE	-	Uint8
21-61	Ext. 3 Proportional Gain	0.01 N/A	All set-ups	TRUE	-2	Uint16
21-62	Ext. 3 Integral Time	10000.00 s	All set-ups	TRUE	-2	Uint32
21-63	Ext. 3 Differentiation Time	0.00 s	All set-ups	TRUE	-2	Uint16
21-64	Ext. 3 Dif. Gain Limit	5.0 N/A	All set-ups	TRUE	-1	Uint16

### 6.2.20 22-\*\* Application Functions

Par. No. #	Parameter description	Default value	4-set-up	Change during operation	Conversion index	Type
<b>22-0* Miscellaneous</b>						
22-00	External Interlock Delay	0 s	All set-ups	TRUE	0	Uint16
22-01	Power Filter Time	0.50 s	2 set-ups	TRUE	-2	Uint16
<b>22-2* No-Flow Detection</b>						
22-20	Low Power Auto Set-up	[0] Off	All set-ups	FALSE	-	Uint8
22-21	Low Power Detection	[0] Disabled	All set-ups	TRUE	-	Uint8
22-22	Low Speed Detection	[0] Disabled	All set-ups	TRUE	-	Uint8
22-23	No-Flow Function	[0] Off	All set-ups	TRUE	-	Uint8
22-24	No-Flow Delay	10 s	All set-ups	TRUE	0	Uint16
22-26	Dry Pump Function	[0] Off	All set-ups	TRUE	-	Uint8
22-27	Dry Pump Delay	10 s	All set-ups	TRUE	0	Uint16
<b>22-3* No-Flow Power Tuning</b>						
22-30	No-Flow Power	0.00 kW	All set-ups	TRUE	1	Uint32
22-31	Power Correction Factor	100 %	All set-ups	TRUE	0	Uint16
22-32	Low Speed [RPM]	SR	All set-ups	TRUE	67	Uint16
22-33	Low Speed [Hz]	SR	All set-ups	TRUE	-1	Uint16
22-34	Low Speed Power [kW]	SR	All set-ups	TRUE	1	Uint32
22-35	Low Speed Power [HP]	SR	All set-ups	TRUE	-2	Uint32
22-36	High Speed [RPM]	SR	All set-ups	TRUE	67	Uint16
22-37	High Speed [Hz]	SR	All set-ups	TRUE	-1	Uint16
22-38	High Speed Power [kW]	SR	All set-ups	TRUE	1	Uint32
22-39	High Speed Power [HP]	SR	All set-ups	TRUE	-2	Uint32
<b>22-4* Sleep Mode</b>						
22-40	Minimum Run Time	10 s	All set-ups	TRUE	0	Uint16
22-41	Minimum Sleep Time	10 s	All set-ups	TRUE	0	Uint16
22-42	Wake-up Speed [RPM]	SR	All set-ups	TRUE	67	Uint16
22-43	Wake-up Speed [Hz]	SR	All set-ups	TRUE	-1	Uint16
22-44	Wake-up Ref./FB Difference	10 %	All set-ups	TRUE	0	Int8
22-45	Setpoint Boost	0 %	All set-ups	TRUE	0	Int8
22-46	Maximum Boost Time	60 s	All set-ups	TRUE	0	Uint16
<b>22-5* End of Curve</b>						
22-50	End of Curve Function	[0] Off	All set-ups	TRUE	-	Uint8
22-51	End of Curve Delay	10 s	All set-ups	TRUE	0	Uint16
<b>22-6* Broken Belt Detection</b>						
22-60	Broken Belt Function	[0] Off	All set-ups	TRUE	-	Uint8
22-61	Broken Belt Torque	10 %	All set-ups	TRUE	0	Uint8
22-62	Broken Belt Delay	10 s	All set-ups	TRUE	0	Uint16
<b>22-7* Short Cycle Protection</b>						
22-75	Short Cycle Protection	[0] Disabled	All set-ups	TRUE	-	Uint8
		start_to_start_min_on_time				
22-76	Interval between Starts	(P2277)	All set-ups	TRUE	0	Uint16
22-77	Minimum Run Time	0 s	All set-ups	TRUE	0	Uint16
22-78	Minimum Run Time Override	[0] Disabled	All set-ups	FALSE	-	Uint8
22-79	Minimum Run Time Override Value	0.000 ProcessCtrlUnit	All set-ups	TRUE	-3	Int32
<b>22-8* Flow Compensation</b>						
22-80	Flow Compensation	[0] Disabled	All set-ups	TRUE	-	Uint8
22-81	Square-linear Curve Approximation	100 %	All set-ups	TRUE	0	Uint8
22-82	Work Point Calculation	[0] Disabled	All set-ups	TRUE	-	Uint8
22-83	Speed at No-Flow [RPM]	SR	All set-ups	TRUE	67	Uint16
22-84	Speed at No-Flow [Hz]	SR	All set-ups	TRUE	-1	Uint16
22-85	Speed at Design Point [RPM]	SR	All set-ups	TRUE	67	Uint16
22-86	Speed at Design Point [Hz]	SR	All set-ups	TRUE	-1	Uint16
22-87	Pressure at No-Flow Speed	0.000 N/A	All set-ups	TRUE	-3	Int32
22-88	Pressure at Rated Speed	999999.999 N/A	All set-ups	TRUE	-3	Int32
22-89	Flow at Design Point	0.000 N/A	All set-ups	TRUE	-3	Int32
22-90	Flow at Rated Speed	0.000 N/A	All set-ups	TRUE	-3	Int32

## 6.2.21 23-\*\* Time Based Functions

Par. No. #	Parameter description	Default value	4-set-up	Change during operation	Conversion index	Type
<b>23-0* Timed Actions</b>						
23-00	ON Time	SR	2 set-ups	TRUE	0	TimeOfDayWoDate
23-01	ON Action	[0] Disabled	2 set-ups	TRUE	-	UInt8
23-02	OFF Time	SR	2 set-ups	TRUE	0	TimeOfDayWoDate
23-03	OFF Action	[0] Disabled	2 set-ups	TRUE	-	UInt8
23-04	Occurrence	[0] All days	2 set-ups	TRUE	-	UInt8
<b>23-1* Maintenance</b>						
23-10	Maintenance Item	[1] Motor bearings	1 set-up	TRUE	-	UInt8
23-11	Maintenance Action	[1] Lubricate	1 set-up	TRUE	-	UInt8
23-12	Maintenance Time Base	[0] Disabled	1 set-up	TRUE	-	UInt8
23-13	Maintenance Time Interval	1 h	1 set-up	TRUE	74	UInt32
23-14	Maintenance Date and Time	SR	1 set-up	TRUE	0	TimeOfDay
<b>23-1* Maintenance Reset</b>						
23-15	Reset Maintenance Word	[0] Do not reset	All set-ups	TRUE	-	UInt8
23-16	Maintenance Text	0 N/A	1 set-up	TRUE	0	VisStr[20]
<b>23-5* Energy Log</b>						
23-50	Energy Log Resolution	[5] Last 24 Hours	2 set-ups	TRUE	-	UInt8
23-51	Period Start	SR	2 set-ups	TRUE	0	TimeOfDay
23-53	Energy Log	0 N/A	All set-ups	TRUE	0	UInt32
23-54	Reset Energy Log	[0] Do not reset	All set-ups	TRUE	-	UInt8
<b>23-6* Trending</b>						
23-60	Trend Variable	[0] Power [kW]	2 set-ups	TRUE	-	UInt8
23-61	Continuous Bin Data	0 N/A	All set-ups	TRUE	0	UInt32
23-62	Timed Bin Data	0 N/A	All set-ups	TRUE	0	UInt32
23-63	Timed Period Start	SR	2 set-ups	TRUE	0	TimeOfDay
23-64	Timed Period Stop	SR	2 set-ups	TRUE	0	TimeOfDay
23-65	Minimum Bin Value	SR	2 set-ups	TRUE	0	UInt8
23-66	Reset Continuous Bin Data	[0] Do not reset	All set-ups	TRUE	-	UInt8
23-67	Reset Timed Bin Data	[0] Do not reset	All set-ups	TRUE	-	UInt8
<b>23-8* Payback Counter</b>						
23-80	Power Reference Factor	100 %	2 set-ups	TRUE	0	UInt8
23-81	Energy Cost	1.00 N/A	2 set-ups	TRUE	-2	UInt32
23-82	Investment	0 N/A	2 set-ups	TRUE	0	UInt32
23-83	Energy Savings	0 kWh	All set-ups	TRUE	75	Int32
23-84	Cost Savings	0 N/A	All set-ups	TRUE	0	Int32



### 6.2.22 24-\*\* Application Functions 2

Par. No. #	Parameter description	Default value	4-set-up	Change during operation	Conversion index	Type
<b>24-0* Fire Mode</b>						
24-00	Fire Mode Function	[0] Disabled	2 set-ups	TRUE	-	UInt8
24-01	Fire Mode Configuration	[0] Open Loop	All set-ups	TRUE	-	UInt8
24-02	Fire Mode Unit	null	All set-ups	TRUE	-	UInt8
24-03	Fire Mode Min Reference	SR	All set-ups	TRUE	-3	Int32
24-04	Fire Mode Max Reference	SR	All set-ups	TRUE	-3	Int32
24-05	Fire Mode Preset Reference	0.00 %	All set-ups	TRUE	-2	Int16
24-06	Fire Mode Reference Source	[0] No function	All set-ups	TRUE	-	UInt8
24-07	Fire Mode Feedback Source	[0] No function	All set-ups	TRUE	-	UInt8
24-09	Fire Mode Alarm Handling	[1] Trip, Critical Alarms	2 set-ups	FALSE	-	UInt8
<b>24-1* Drive Bypass</b>						
24-10	Drive Bypass Function	[0] Disabled	2 set-ups	TRUE	-	UInt8
24-11	Drive Bypass Delay Time	0 s	2 set-ups	TRUE	0	UInt16
<b>24-9* Multi-Motor Funct.</b>						
24-90	Missing Motor Function	[0] Off	All set-ups	TRUE	-	UInt8
24-91	Missing Motor Coefficient 1	0.0000 N/A	All set-ups	TRUE	-4	Int32
24-92	Missing Motor Coefficient 2	0.0000 N/A	All set-ups	TRUE	-4	Int32
24-93	Missing Motor Coefficient 3	0.0000 N/A	All set-ups	TRUE	-4	Int32
24-94	Missing Motor Coefficient 4	0.000 N/A	All set-ups	TRUE	-3	Int32
24-95	Locked Rotor Function	[0] Off	All set-ups	TRUE	-	UInt8
24-96	Locked Rotor Coefficient 1	0.0000 N/A	All set-ups	TRUE	-4	Int32
24-97	Locked Rotor Coefficient 2	0.0000 N/A	All set-ups	TRUE	-4	Int32
24-98	Locked Rotor Coefficient 3	0.0000 N/A	All set-ups	TRUE	-4	Int32
24-99	Locked Rotor Coefficient 4	0.000 N/A	All set-ups	TRUE	-3	Int32



## 6.2.23 25-\*\* Cascade Pack Controller

Par. No. #	Parameter description	Default value	4-set-up	Change during operation	Conversion index	Type
<b>25-0* System Settings</b>						
25-00	Cascade Controller	[0] Disabled	2 set-ups	FALSE	-	Uint8
25-02	Motor Start	[0] Direct on Line	2 set-ups	FALSE	-	Uint8
25-04	Pump Cycling	[0] Disabled	All set-ups	TRUE	-	Uint8
25-05	Fixed Lead Pump	[1] Yes	2 set-ups	FALSE	-	Uint8
25-06	Number of Pumps	2 N/A	2 set-ups	FALSE	0	Uint8
<b>25-2* Bandwidth Settings</b>						
25-20	Staging Bandwidth	10 %	All set-ups	TRUE	0	Uint8
25-21	Override Bandwidth	100 %	All set-ups	TRUE	0	Uint8
casco_staging_bandwidth						
25-22	Fixed Speed Bandwidth	(P2520)	All set-ups	TRUE	0	Uint8
25-23	SBW Staging Delay	15 s	All set-ups	TRUE	0	Uint16
25-24	SBW Destaging Delay	15 s	All set-ups	TRUE	0	Uint16
25-25	OBW Time	10 s	All set-ups	TRUE	0	Uint16
25-26	Destage At No-Flow	[0] Disabled	All set-ups	TRUE	-	Uint8
25-27	Stage Function	[1] Enabled	All set-ups	TRUE	-	Uint8
25-28	Stage Function Time	15 s	All set-ups	TRUE	0	Uint16
25-29	Destage Function	[1] Enabled	All set-ups	TRUE	-	Uint8
25-30	Destage Function Time	15 s	All set-ups	TRUE	0	Uint16
<b>25-4* Staging Settings</b>						
25-40	Ramp Down Delay	10.0 s	All set-ups	TRUE	-1	Uint16
25-41	Ramp Up Delay	2.0 s	All set-ups	TRUE	-1	Uint16
25-42	Staging Threshold	SR	All set-ups	TRUE	0	Uint8
25-43	Destaging Threshold	SR	All set-ups	TRUE	0	Uint8
25-44	Staging Speed [RPM]	0 RPM	All set-ups	TRUE	67	Uint16
25-45	Staging Speed [Hz]	0.0 Hz	All set-ups	TRUE	-1	Uint16
25-46	Destaging Speed [RPM]	0 RPM	All set-ups	TRUE	67	Uint16
25-47	Destaging Speed [Hz]	0.0 Hz	All set-ups	TRUE	-1	Uint16
<b>25-5* Alternation Settings</b>						
25-50	Lead Pump Alternation	[0] Off	All set-ups	TRUE	-	Uint8
25-51	Alternation Event	[0] External	All set-ups	TRUE	-	Uint8
25-52	Alternation Time Interval	24 h	All set-ups	TRUE	74	Uint16
25-53	Alternation Timer Value	0 N/A	All set-ups	TRUE	0	VisStr[7]
25-54	Alternation Predefined Time	SR	All set-ups	TRUE	0	TimeOfDayWoDate
25-55	Alternate if Load < 50%	[1] Enabled	All set-ups	TRUE	-	Uint8
25-56	Staging Mode at Alternation	[0] Slow	All set-ups	TRUE	-	Uint8
25-58	Run Next Pump Delay	0.1 s	All set-ups	TRUE	-1	Uint16
25-59	Run on Mains Delay	0.5 s	All set-ups	TRUE	-1	Uint16
<b>25-8* Status</b>						
25-80	Cascade Status	0 N/A	All set-ups	TRUE	0	VisStr[25]
25-81	Pump Status	0 N/A	All set-ups	TRUE	0	VisStr[25]
25-82	Lead Pump	0 N/A	All set-ups	TRUE	0	Uint8
25-83	Relay Status	0 N/A	All set-ups	TRUE	0	VisStr[4]
25-84	Pump ON Time	0 h	All set-ups	TRUE	74	Uint32
25-85	Relay ON Time	0 h	All set-ups	TRUE	74	Uint32
25-86	Reset Relay Counters	[0] Do not reset	All set-ups	TRUE	-	Uint8
<b>25-9* Service</b>						
25-90	Pump Interlock	[0] Off	All set-ups	TRUE	-	Uint8
25-91	Manual Alternation	0 N/A	All set-ups	TRUE	0	Uint8

**6.2.24 26-\*\* Analog I / O Option MCB 109**

Par. No. #	Parameter description	Default value	4-set-up	Change during operation	Conversion index	Type
<b>26-0* Analog I/O Mode</b>						
26-00	Terminal X42/1 Mode	[1] Voltage	All set-ups	TRUE	-	Uint8
26-01	Terminal X42/3 Mode	[1] Voltage	All set-ups	TRUE	-	Uint8
26-02	Terminal X42/5 Mode	[1] Voltage	All set-ups	TRUE	-	Uint8
<b>26-1* Analog Input X42/1</b>						
26-10	Terminal X42/1 Low Voltage	0.07 V	All set-ups	TRUE	-2	Int16
26-11	Terminal X42/1 High Voltage	10.00 V	All set-ups	TRUE	-2	Int16
26-14	Term. X42/1 Low Ref./Feedb. Value	0.000 N/A	All set-ups	TRUE	-3	Int32
26-15	Term. X42/1 High Ref./Feedb. Value	100.000 N/A	All set-ups	TRUE	-3	Int32
26-16	Term. X42/1 Filter Time Constant	0.001 s	All set-ups	TRUE	-3	Uint16
26-17	Term. X42/1 Live Zero	[1] Enabled	All set-ups	TRUE	-	Uint8
<b>26-2* Analog Input X42/3</b>						
26-20	Terminal X42/3 Low Voltage	0.07 V	All set-ups	TRUE	-2	Int16
26-21	Terminal X42/3 High Voltage	10.00 V	All set-ups	TRUE	-2	Int16
26-24	Term. X42/3 Low Ref./Feedb. Value	0.000 N/A	All set-ups	TRUE	-3	Int32
26-25	Term. X42/3 High Ref./Feedb. Value	100.000 N/A	All set-ups	TRUE	-3	Int32
26-26	Term. X42/3 Filter Time Constant	0.001 s	All set-ups	TRUE	-3	Uint16
26-27	Term. X42/3 Live Zero	[1] Enabled	All set-ups	TRUE	-	Uint8
<b>26-3* Analog Input X42/5</b>						
26-30	Terminal X42/5 Low Voltage	0.07 V	All set-ups	TRUE	-2	Int16
26-31	Terminal X42/5 High Voltage	10.00 V	All set-ups	TRUE	-2	Int16
26-34	Term. X42/5 Low Ref./Feedb. Value	0.000 N/A	All set-ups	TRUE	-3	Int32
26-35	Term. X42/5 High Ref./Feedb. Value	100.000 N/A	All set-ups	TRUE	-3	Int32
26-36	Term. X42/5 Filter Time Constant	0.001 s	All set-ups	TRUE	-3	Uint16
26-37	Term. X42/5 Live Zero	[1] Enabled	All set-ups	TRUE	-	Uint8
<b>26-4* Analog Out X42/7</b>						
26-40	Terminal X42/7 Output	[0] No operation	All set-ups	TRUE	-	Uint8
26-41	Terminal X42/7 Min. Scale	0.00 %	All set-ups	TRUE	-2	Int16
26-42	Terminal X42/7 Max. Scale	100.00 %	All set-ups	TRUE	-2	Int16
26-43	Terminal X42/7 Bus Control	0.00 %	All set-ups	TRUE	-2	N2
26-44	Terminal X42/7 Timeout Preset	0.00 %	1 set-up	TRUE	-2	Uint16
<b>26-5* Analog Out X42/9</b>						
26-50	Terminal X42/9 Output	[0] No operation	All set-ups	TRUE	-	Uint8
26-51	Terminal X42/9 Min. Scale	0.00 %	All set-ups	TRUE	-2	Int16
26-52	Terminal X42/9 Max. Scale	100.00 %	All set-ups	TRUE	-2	Int16
26-53	Terminal X42/9 Bus Control	0.00 %	All set-ups	TRUE	-2	N2
26-54	Terminal X42/9 Timeout Preset	0.00 %	1 set-up	TRUE	-2	Uint16
<b>26-6* Analog Out X42/11</b>						
26-60	Terminal X42/11 Output	[0] No operation	All set-ups	TRUE	-	Uint8
26-61	Terminal X42/11 Min. Scale	0.00 %	All set-ups	TRUE	-2	Int16
26-62	Terminal X42/11 Max. Scale	100.00 %	All set-ups	TRUE	-2	Int16
26-63	Terminal X42/11 Bus Control	0.00 %	All set-ups	TRUE	-2	N2
26-64	Terminal X42/11 Timeout Preset	0.00 %	1 set-up	TRUE	-2	Uint16





7

## 7 General Specifications

### Mains supply (L1, L2, L3):

Supply voltage	380-480 V ±10%
Supply voltage	525-690 V ±10%
Supply frequency	50/60 Hz
Max. imbalance temporary between mains phases	3.0 % of rated supply voltage
True Power Factor (λ)	≥ 0.9 nominal at rated load
Displacement Power Factor (cosφ) near unity	(> 0.98)
Switching on input supply L1, L2, L3 (power-ups)	maximum once/2 min.
Environment according to EN60664-1	overvoltage category III / pollution degree 2

*The unit is suitable for use on a circuit capable of delivering not more than 100.000 RMS symmetrical Amperes, 480/690 V maximum.*

### Motor output (U, V, W):

Output voltage	0 - 100% of supply voltage
Output frequency	0 - 800* Hz
Switching on output	Unlimited
Ramp times	1 - 3600 sec.

\* Voltage and power dependent

### Torque characteristics:

Starting torque (Constant torque)	maximum 110% for 1 min.*
Starting torque	maximum 135% up to 0.5 sec.*
Overload torque (Constant torque)	maximum 110% for 1 min.*

*\*Percentage relates to the frequency converter's nominal torque.*

### Cable lengths and cross sections:

Max. motor cable length, screened/armoured	150 m
Max. motor cable length, unscreened/unarmoured	300 m
Max. cross section to motor, mains, load sharing and brake *	
Maximum cross section to control terminals, rigid wire	1.5 mm <sup>2</sup> /16 AWG (2 x 0.75 mm <sup>2</sup> )
Maximum cross section to control terminals, flexible cable	1 mm <sup>2</sup> /18 AWG
Maximum cross section to control terminals, cable with enclosed core	0.5 mm <sup>2</sup> /20 AWG
Minimum cross section to control terminals	0.25 mm <sup>2</sup>

*\* See Mains Supply tables for more information!*

### Digital inputs:

Programmable digital inputs	4 (6)
Terminal number	18, 19, 27 <sup>1)</sup> , 29 <sup>1)</sup> , 32, 33,
Logic	PNP or NPN
Voltage level	0 - 24 V DC
Voltage level, logic '0' PNP	< 5 V DC
Voltage level, logic '1' PNP	> 10 V DC
Voltage level, logic '0' NPN	> 19 V DC
Voltage level, logic '1' NPN	< 14 V DC
Maximum voltage on input	28 V DC
Input resistance, R <sub>i</sub>	approx. 4 kΩ

*All digital inputs are galvanically isolated from the supply voltage (PELV) and other high-voltage terminals.*

*1) Terminals 27 and 29 can also be programmed as output.*



## Analog inputs:

Number of analog inputs	2
Terminal number	53, 54
Modes	Voltage or current
Mode select	Switch S201 and switch S202
Voltage mode	Switch S201/switch S202 = OFF (U)
Voltage level	: 0 to + 10 V (scaleable)
Input resistance, $R_i$	approx. 10 k $\Omega$
Max. voltage	$\pm 20$ V
Current mode	Switch S201/switch S202 = ON (I)
Current level	0/4 to 20 mA (scaleable)
Input resistance, $R_i$	approx. 200 $\Omega$
Max. current	30 mA
Resolution for analog inputs	10 bit (+ sign)
Accuracy of analog inputs	Max. error 0.5% of full scale
Bandwidth	: 200 Hz

The analog inputs are galvanically isolated from the supply voltage (PELV) and other high-voltage terminals.

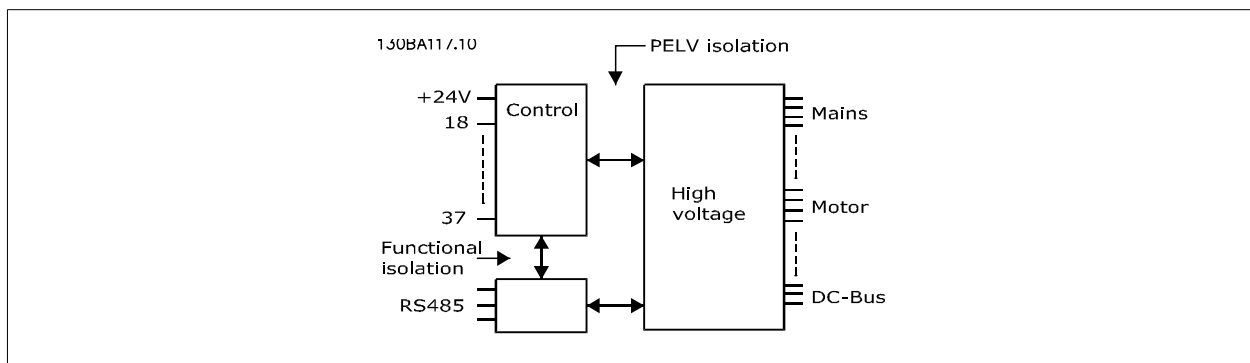

## Pulse inputs:

Programmable pulse inputs	2
Terminal number pulse	29, 33
Max. frequency at terminal, 29, 33	110 kHz (Push-pull driven)
Max. frequency at terminal, 29, 33	5 kHz (open collector)
Min. frequency at terminal 29, 33	4 Hz
Voltage level	see section on Digital input
Maximum voltage on input	28 V DC
Input resistance, $R_i$	approx. 4 k $\Omega$
Pulse input accuracy (0.1 - 1 kHz)	Max. error: 0.1% of full scale

## Analog output:

Number of programmable analog outputs	1
Terminal number	42
Current range at analog output	0/4 - 20 mA
Max. resistor load to common at analog output	500 $\Omega$
Accuracy on analog output	Max. error: 0.8 % of full scale
Resolution on analog output	8 bit

The analog output is galvanically isolated from the supply voltage (PELV) and other high-voltage terminals.

## Control card, RS-485 serial communication:

Terminal number	68 (P,TX+, RX+), 69 (N,TX-, RX-)
Terminal number 61	Common for terminals 68 and 69

The RS-485 serial communication circuit is functionally seated from other central circuits and galvanically isolated from the supply voltage (PELV).

Digital output:

Programmable digital/pulse outputs	2
Terminal number	27, 29 <sup>1)</sup>
Voltage level at digital/frequency output	0 - 24 V
Max. output current (sink or source)	40 mA
Max. load at frequency output	1 kΩ
Max. capacitive load at frequency output	10 nF
Minimum output frequency at frequency output	0 Hz
Maximum output frequency at frequency output	32 kHz
Accuracy of frequency output	Max. error: 0.1 % of full scale
Resolution of frequency outputs	12 bit

1) Terminal 27 and 29 can also be programmed as input.

The digital output is galvanically isolated from the supply voltage (PELV) and other high-voltage terminals.

Control card, 24 V DC output:

Terminal number	12, 13
Max. load	: 200 mA

The 24 V DC supply is galvanically isolated from the supply voltage (PELV), but has the same potential as the analog and digital inputs and outputs.

Relay outputs:

Programmable relay outputs	2
<b>Relay 01 Terminal number</b>	1-3 (break), 1-2 (make)
Max. terminal load (AC-1) <sup>1)</sup> on 1-3 (NC), 1-2 (NO) (Resistive load)	240 V AC, 2 A
Max. terminal load (AC-15) <sup>1)</sup> (Inductive load @ cosφ 0.4)	240 V AC, 0.2 A
Max. terminal load (DC-1) <sup>1)</sup> on 1-2 (NO), 1-3 (NC) (Resistive load)	60 V DC, 1A
Max. terminal load (DC-13) <sup>1)</sup> (Inductive load)	24 V DC, 0.1A
<b>Relay 02 Terminal number</b>	4-6 (break), 4-5 (make)
Max. terminal load (AC-1) <sup>1)</sup> on 4-5 (NO) (Resistive load) <sup>2)3)</sup>	400 V AC, 2 A
Max. terminal load (AC-15) <sup>1)</sup> on 4-5 (NO) (Inductive load @ cosφ 0.4)	240 V AC, 0.2 A
Max. terminal load (DC-1) <sup>1)</sup> on 4-5 (NO) (Resistive load)	80 V DC, 2 A
Max. terminal load (DC-13) <sup>1)</sup> on 4-5 (NO) (Inductive load)	24 V DC, 0.1A
Max. terminal load (AC-1) <sup>1)</sup> on 4-6 (NC) (Resistive load)	240 V AC, 2 A
Max. terminal load (AC-15) <sup>1)</sup> on 4-6 (NC) (Inductive load @ cosφ 0.4)	240 V AC, 0.2A
Max. terminal load (DC-1) <sup>1)</sup> on 4-6 (NC) (Resistive load)	50 V DC, 2 A
Max. terminal load (DC-13) <sup>1)</sup> on 4-6 (NC) (Inductive load)	24 V DC, 0.1 A
Min. terminal load on 1-3 (NC), 1-2 (NO), 4-6 (NC), 4-5 (NO)	24 V DC 10 mA, 24 V AC 20 mA
Environment according to EN 60664-1	overvoltage category III/pollution degree 2

1) IEC 60947 t 4 and 5

The relay contacts are galvanically isolated from the rest of the circuit by reinforced isolation (PELV).

2) Overvoltage Category II

3) UL applications 300 V AC 2A

Control card, 10 V DC output:

Terminal number	50
Output voltage	10.5 V ±0.5 V
Max. load	25 mA

The 10 V DC supply is galvanically isolated from the supply voltage (PELV) and other high-voltage terminals.

Control characteristics:

Resolution of output frequency at 0 - 1000 Hz	: +/- 0.003 Hz
System response time (terminals 18, 19, 27, 29, 32, 33)	: ≤ 2 ms
Speed control range (open loop)	1:100 of synchronous speed
Speed accuracy (open loop)	30 - 4000 rpm: Maximum error of ±8 rpm

All control characteristics are based on a 4-pole asynchronous motor

Surroundings:

Enclosure, frame size D and E	IP 00, IP 21, IP 54
Enclosure, frame size F	IP 21, IP 54
Vibration test	0.7 g



Relative humidity	5% - 95%(IEC 721-3-3; Class 3K3 (non-condensing) during operation
Aggressive environment (IEC 721-3-3), uncoated	class 3C2
Aggressive environment (IEC 721-3-3), coated	class 3C3
Test method according to IEC 60068-2-43 H2S (10 days)	
Ambient temperature (at 60 AVM switching mode)	
- with derating	max. 55 ° C <sup>1)</sup>
- with full output power, typical EFF2 motors	max. 50 ° C <sup>1)</sup>
- at full continuous FC output current	max. 45 ° C <sup>1)</sup>

<sup>1)</sup> For more information on derating see the Design Guide, section on Special Conditions.

Minimum ambient temperature during full-scale operation	0 °C
Minimum ambient temperature at reduced performance	- 10 °C
Temperature during storage/transport	-25 - +65/70 °C
Maximum altitude above sea level without derating	1000 m
Maximum altitude above sea level with derating	3000 m

Derating for high altitude, see section on special conditions

EMC standards, Emission	EN 61800-3, EN 61000-6-3/4, EN 55011, IEC 61800-3 EN 61800-3, EN 61000-6-1/2,
EMC standards, Immunity	EN 61000-4-2, EN 61000-4-3, EN 61000-4-4, EN 61000-4-5, EN 61000-4-6

See section on special conditions!

Control card performance:	
Scan interval	: 5 ms
Control card, USB serial communication:	
USB standard	1.1 (Full speed)
USB plug	USB type B "device" plug



Connection to PC is carried out via a standard host/device USB cable.

The USB connection is galvanically isolated from the supply voltage (PELV) and other high-voltage terminals.

The USB connection is not galvanically isolated from protection earth. Use only isolated laptop/PC as connection to the USB connector on the frequency converter or an isolated USB cable/converter.

#### Protection and Features:

- Electronic thermal motor protection against overload.
- Temperature monitoring of the heatsink ensures that the frequency converter trips if the temperature reaches 95 °C ± 5°C. An overload temperature cannot be reset until the temperature of the heatsink is below 70 °C ± 5°C (Guideline - these temperatures may vary for different power sizes, enclosures etc.). The frequency converter has an auto derating function to avoid its heatsink reaching 95 °C.
- The frequency converter is protected against short-circuits on motor terminals U, V, W.
- If a mains phase is missing, the frequency converter trips or issues a warning (depending on the load).
- Monitoring of the intermediate circuit voltage ensures that the frequency converter trips if the intermediate circuit voltage is too low or too high.
- The frequency converter is protected against earth faults on motor terminals U, V, W.



<b>Mains Supply 3 x 380 - 480 VAC</b>		P110	P132	P160	P200	P250
	Typical Shaft output at 400 V [kW]	110	132	160	200	250
	Typical Shaft output at 460 V [HP]	150	200	250	300	350
	Enclosure IP21	D1	D1	D2	D2	D2
	Enclosure IP54	D1	D1	D2	D2	D2
	Enclosure IP00	D3	D3	D4	D4	D4
<b>Output current</b>						
	Continuous (at 400 V) [A]	212	260	315	395	480
	Intermittent (60 sec overload) (at 400 V) [A]	233	286	347	435	528
	Continuous (at 460/ 480 V) [A]	190	240	302	361	443
	Intermittent (60 sec overload) (at 460/ 480 V) [A]	209	264	332	397	487
	Continuous KVA (at 400 V) [KVA]	147	180	218	274	333
	Continuous KVA (at 460 V) [KVA]	151	191	241	288	353
<b>Max. input current</b>						
	Continuous (at 400 V) [A]	204	251	304	381	463
	Continuous (at 460/ 480 V) [A]	183	231	291	348	427
	Max. cable size, mains motor, brake and load share [mm <sup>2</sup> (AWG <sup>2</sup> )]	2 x 70 (2 x 2/0)	2 x 70 (2 x 2/0)	2 x 150 (2 x 300 mcm)	2 x 150 (2 x 300 mcm)	2 x 150 (2 x 300 mcm)
	Max. external pre-fuses [A] <sup>1</sup>	300	350	400	500	630
	Estimated power loss at rated max. load [W] <sup>4)</sup> , 400 V	3234	3782	4213	5119	5893
	Estimated power loss at rated max. load [W] <sup>4)</sup> , 460 V	2947	3665	4063	4652	5634
	Weight, enclosure IP21, IP 54 [kg]	96	104	125	136	151
	Weight, enclosure IP00 [kg]	82	91	112	123	138
	Efficiency <sup>4)</sup>	0.98				
	Output frequency	0 - 800 Hz				
	Heatsink overtemp. trip	85 °C	90 °C	105 °C	105 °C	115 °C
	Power card ambient trip	60 °C				

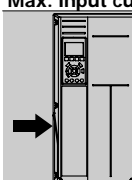
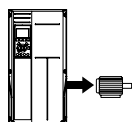

<b>Mains Supply 3 x 380 - 480 VAC</b>				
	P315	P355	P400	P450
Typical Shaft output at 400 V [kW]	315	355	400	450
Typical Shaft output at 460 V [HP]	450	500	600	600
Enclosure IP21	E1	E1	E1	E1
Enclosure IP54	E1	E1	E1	E1
Enclosure IP00	E2	E2	E2	E2
<b>Output current</b>				
Continuous (at 400 V) [A]	600	658	745	800
Intermittent (60 sec over-load) (at 400 V) [A]	660	724	820	880
Continuous (at 460/ 480 V) [A]	540	590	678	730
Intermittent (60 sec over-load) (at 460/ 480 V) [A]	594	649	746	803
Continuous KVA (at 400 V) [KVA]	416	456	516	554
Continuous KVA (at 460 V) [KVA]	430	470	540	582
<b>Max. input current</b>				
Continuous (at 400 V) [A]	590	647	733	787
Continuous (at 460/ 480 V) [A]	531	580	667	718
Max. cable size, mains, motor and load share [mm <sup>2</sup> (AWG <sup>2</sup> )]	4x240 (4x500 mcm)	4x240 (4x500 mcm)	4x240 (4x500 mcm)	4x240 (4x500 mcm)
Max. cable size, brake [mm <sup>2</sup> (AWG <sup>2</sup> )]	2 x 185 (2 x 350 mcm)	2 x 185 (2 x 350 mcm)	2 x 185 (2 x 350 mcm)	2 x 185 (2 x 350 mcm)
Max. external pre-fuses [A] <sup>1</sup>	700	900	900	900
Estimated power loss at rated max. load [W] <sup>4</sup> , 400 V	6790	7701	8879	9670
Estimated power loss at rated max. load [W] <sup>4</sup> , 460 V	6082	6953	8089	8803
Weight, enclosure IP21, IP 54 [kg]	263	270	272	313
Weight, enclosure IP00 [kg]	221	234	236	277
Efficiency <sup>3</sup>	0.98			
Output frequency	0 - 600 Hz			
Heatsink overtemp. trip	95 °C			
Power card ambient trip	68 °C			

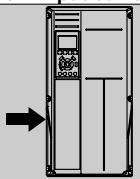
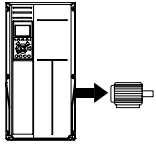

7

<b>Mains Supply 3 x 380 - 480 VAC</b>		P500	P560	P630	P710	P800	P1M0	
	Typical Shaft output at 400 V [kW]	500	560	630	710	800	1000	
	Typical Shaft output at 460 V [HP]	650	750	900	1000	1200	1350	
	Enclosure IP21, 54 without/ with options cabinet	F1/F3	F1/F3	F1/F3	F1/F3	F2/F4	F2/F4	
	<b>Output current</b>							
	Continuous (at 400 V) [A]	880	990	1120	1260	1460	1720	
	Intermittent (60 sec overload) (at 400 V) [A]	968	1089	1232	1386	1606	1892	
	Continuous (at 460/ 480 V) [A]	780	890	1050	1160	1380	1530	
	Intermittent (60 sec overload) (at 460/ 480 V) [A]	858	979	1155	1276	1518	1683	
	Continuous KVA (at 400 V) [KVA]	610	686	776	873	1012	1192	
	Continuous KVA (at 460 V) [KVA]	621	709	837	924	1100	1219	
<b>Max. input current</b>								
	Continuous (at 400 V ) [A]	857	964	1090	1227	1422	1675	
	Continuous (at 460/ 480 V) [A]	759	867	1022	1129	1344	1490	
	Max. cable size, motor [mm <sup>2</sup> (AWG <sup>2</sup> )]	8x150 (8x300 mcm)				12x150 (12x300 mcm)		
	Max. cable size, mains [mm <sup>2</sup> (AWG <sup>2</sup> )]	8x240 (8x500 mcm)						
	Max. cable size, loadsharing [mm <sup>2</sup> (AWG <sup>2</sup> )]	4x120 (4x250 mcm)						
	Max. cable size, brake [mm <sup>2</sup> (AWG <sup>2</sup> )]	4x185 (4x350 mcm)				6x185 (6x350 mcm)		
	Max. external pre-fuses [A] <sup>1</sup>	1600		2000		2500		
	Est. power loss at rated max. load [W] <sup>4</sup> , 400 V, F1 & F2	10647	12338	13201	15436	18084	20358	
	Est. power loss at rated max. load [W] <sup>4</sup> , 460 V, F1 & F2	9414	11006	12353	14041	17137	17752	
	Max added losses of A1 RFI, Circuit Breaker or Disconnect, & Contactor, F3 & F4	963	1054	1093	1230	2280	2541	
Max Panel Options Losses	400							
Weight, enclosure IP21, IP 54 [kg]	1004/ 1299	1004/ 1299	1004/ 1299	1004/ 1299	1246/ 1541	1246/ 1541		
Weight Rectifier Module [kg]	102	102	102	102	136	136		
Weight Inverter Module [kg]	102	102	102	136	102	102		
Efficiency <sup>4</sup>	0.98							
Output frequency	0-600 Hz							
Heatsink overtemp. trip	95 °C							
Power card ambient trip	68 °C							

7

<b>Mains Supply 3 x 525- 690 VAC</b>						
	P45K	P55K	P75K	P90K	P110	
Typical Shaft output at 550 V [kW]	37	45	55	75	90	
Typical Shaft output at 575 V [HP]	50	60	75	100	125	
Typical Shaft output at 690 V [kW]	45	55	75	90	110	
Enclosure IP21	D1	D1	D1	D1	D1	
Enclosure IP54	D1	D1	D1	D1	D1	
Enclosure IP00	D2	D2	D2	D2	D2	
<b>Output current</b>						
	Continuous (at 3 x 525-550 V) [A]	56	76	90	113	137
	Intermittent (60 sec overload) (at 550 V) [A]	62	84	99	124	151
	Continuous (at 3 x 551-690 V) [A]	54	73	86	108	131
	Intermittent (60 sec overload) (at 575/ 690 V) [A]	59	80	95	119	144
	Continuous KVA (at 550 V) [KVA]	53	72	86	108	131
	Continuous KVA (at 575 V) [KVA]	54	73	86	108	130
	Continuous KVA (at 690 V) [KVA]	65	87	103	129	157
	<b>Max. input current</b>					
		Continuous (at 550 V ) [A]	60	77	89	110
Continuous (at 575 V ) [A]		58	74	85	106	124
Continuous (at 690 V ) [A]		58	77	87	109	128
Max. cable size, mains, motor, load share and brake [mm <sup>2</sup> (AWG)]	2x70 (2x2/0)					
Max. external pre-fuses [A] <sup>1</sup>	125	160	200	200	250	
Estimated power loss at rated max. load [W] <sup>4)</sup> , 600 V	1398	1645	1827	2157	2533	
Estimated power loss at rated max. load [W] <sup>4)</sup> , 690 V	1458	1717	1913	2262	2662	
Weight, enclosure IP21, IP 54 [kg]	96					
Weight, enclosure IP00 [kg]	82					
Efficiency <sup>4)</sup>	0.97	0.97	0.98	0.98	0.98	
Output frequency	0 - 600 Hz					
Heatsink overtemp. trip	85 °C					
Power card ambient trip	60 °C					

<b>Mains Supply 3 x 525- 690 VAC</b>						
	P132	P160	P200	P250		
Typical Shaft output at 550 V [kW]	110	132	160	200		
Typical Shaft output at 575 V [HP]	150	200	250	300		
Typical Shaft output at 690 V [kW]	132	160	200	250		
Enclosure IP21	D1	D1	D2	D2		
Enclosure IP54	D1	D1	D2	D2		
Enclosure IP00	D3	D3	D4	D4		
<b>Output current</b>						
	Continuous (at 550 V) [A]	162	201	253	303	
	Intermittent (60 sec over-load) (at 550 V) [A]	178	221	278	333	
	Continuous (at 575/ 690 V) [A]	155	192	242	290	
	Intermittent (60 sec over-load) (at 575/ 690 V) [A]	171	211	266	319	
	Continuous KVA (at 550 V) [KVA]	154	191	241	289	
	Continuous KVA (at 575 V) [KVA]	154	191	241	289	
	Continuous KVA (at 690 V) [KVA]	185	229	289	347	
	<b>Max. input current</b>					
		Continuous (at 550 V ) [A]	158	198	245	299
		Continuous (at 575 V) [A]	151	189	234	286
Continuous (at 690 V) [A]		155	197	240	296	
Max. cable size, mains motor, load share and brake [mm <sup>2</sup> (AWG)]		2 x 70 (2 x 2/0)	2 x 70 (2 x 2/0)	2 x 150 (2 x 300 mcm)	2 x 150 (2 x 300 mcm)	
Max. external pre-fuses [A] <sub>1</sub>		315	350	350	400	
Estimated power loss at rated max. load [W] <sup>4)</sup> , 600 V		2963	3430	4051	4867	
Estimated power loss at rated max. load [W] <sup>4)</sup> , 690 V		3430	3612	4292	5156	
Weight, Enclosure IP21, IP 54 [kg]	96	104	125	136		
Weight, Enclosure IP00 [kg]	82	91	112	123		
Efficiency <sup>4)</sup>	0.98					
Output frequency	0 - 600 Hz					
Heatsink overtemp. trip	85 °C	90 °C	110 °C	110 °C		
Power card ambient trip	60 °C					

**Mains Supply 3 x 525- 690 VAC**

	P315	P400	P450
Typical Shaft output at 550 V [kW]	250	315	355
Typical Shaft output at 575 V [HP]	350	400	450
Typical Shaft output at 690 V [kW]	315	400	450
Enclosure IP21	D2	D2	E1
Enclosure IP54	D2	D2	E1
Enclosure IP00	D4	D4	E2

**Output current**

	Continuous (at 550 V) [A]	360	418	470
	Intermittent (60 sec overload) (at 550 V) [A]	396	460	517
	Continuous (at 575/ 690 V) [A]	344	400	450
	Intermittent (60 sec overload) (at 575/ 690 V) [A]	378	440	495
	Continuous KVA (at 550 V) [KVA]	343	398	448
	Continuous KVA (at 575 V) [KVA]	343	398	448
	Continuous KVA (at 690 V) [KVA]	411	478	538

**Max. input current**

	Continuous (at 550 V ) [A]	355	408	453
	Continuous (at 575 V) [A]	339	390	434
	Continuous (at 690 V) [A]	352	400	434
Max. cable size, mains, motor and load share [mm <sup>2</sup> (AWG)]	2 x 150 (2 x 300 mcm)	2 x 150 (2 x 300 mcm)	4 x 240 (4 x 500 mcm)	
Max. cable size, brake [mm <sup>2</sup> (AWG)]	2 x 150 (2 x 300 mcm)	2 x 150 (2 x 300 mcm)	2 x 185 (2 x 350 mcm)	
Max. external pre-fuses [A] <sup>1</sup>	500	550	700	
Estimated power loss at rated max. load [W] <sup>4)</sup> , 600 V	5493	5852	6132	
Estimated power loss at rated max. load [W] <sup>4)</sup> , 690 V	5821	6149	6440	
Weight, enclosure IP21, IP 54 [kg]	151	165	263	
Weight, enclosure IP00 [kg]	138	151	221	
Efficiency <sup>4)</sup>	0.98			
Output frequency	0 - 600 Hz	0 - 500 Hz	0 - 500 Hz	
Heatsink overtemp. trip	110 °C	110 °C	85 °C	
Power card ambient trip	60 °C	60 °C	68 °C	

7

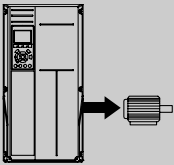
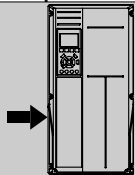
<b>Mains Supply 3 x 525- 690 VAC</b>					
	P500	P560	P630		
Typical Shaft output at 550 V [kW]	400	450	500		
Typical Shaft output at 575 V [HP]	500	600	650		
Typical Shaft output at 690 V [kW]	500	560	630		
Enclosure IP21	E1	E1	E1		
Enclosure IP54	E1	E1	E1		
Enclosure IP00	E2	E2	E2		
<b>Output current</b>					
	Continuous (at 550 V) [A]	523	596	630	
	Intermittent (60 sec overload) (at 550 V) [A]	575	656	693	
	Continuous (at 575/ 690 V) [A]	500	570	630	
	Intermittent (60 sec overload) (at 575/ 690 V) [A]	550	627	693	
	Continuous KVA (at 550 V) [KVA]	498	568	600	
	Continuous KVA (at 575 V) [KVA]	498	568	627	
	Continuous KVA (at 690 V) [KVA]	598	681	753	
	<b>Max. input current</b>				
		Continuous (at 550 V ) [A]	504	574	607
		Continuous (at 575 V) [A]	482	549	607
Continuous (at 690 V) [A]		482	549	607	
Max. cable size, mains, motor and load share [mm <sup>2</sup> (AWG)]	4x240 (4x500 mcm)	4x240 (4x500 mcm)	4x240 (4x500 mcm)		
Max. cable size, brake [mm <sup>2</sup> (AWG)]	2 x 185 (2 x 350 mcm)	2 x 185 (2 x 350 mcm)	2 x 185 (2 x 350 mcm)		
Max. external pre-fuses [A] <sup>1</sup>	700	900	900		
Estimated power loss at rated max. load [W] <sup>4</sup> , 600 V	6903	8343	9244		
Estimated power loss at rated max. load [W] <sup>4</sup> , 690 V	7249	8727	9673		
Weight, enclosure IP21, IP 54 [kg]	263	272	313		
Weight, enclosure IP00 [kg]	221	236	277		
Efficiency <sup>4)</sup>	0.98				
Output frequency	0 - 500 Hz				
Heatsink overtemp. trip	85 °C				
Power card ambient trip	68 °C				

7

Mains Supply 3 x 525- 690 VAC								
	P710	P800	P900	P1M0	P1M2	P1M4		
Typical Shaft output at 550 V [kW]	560	670	750	850	1000	1100		
Typical Shaft output at 575 V [HP]	750	950	1050	1150	1350	1550		
Typical Shaft output at 690 V [kW]	710	800	900	1000	1200	1400		
Enclosure IP21, 54 without/ with options cabinet	F1/ F3	F1/ F3	F1/ F3	F2/ F4	F2/ F4	F2/F4		
<b>Output current</b>								
	Continuous (at 550 V) [A]	763	889	988	1108	1317	1479	
	Intermittent (60 s overload, at 550 V) [A]	839	978	1087	1219	1449	1627	
	Continuous (at 575/ 690 V) [A]	730	850	945	1060	1260	1415	
	Intermittent (60 s overload, at 575/690 V) [A]	803	935	1040	1166	1386	1557	
	Continuous KVA (at 550 V) [KVA]	727	847	941	1056	1255	1409	
	Continuous KVA (at 575 V) [KVA]	727	847	941	1056	1255	1409	
	Continuous KVA (at 690 V) [KVA]	872	1016	1129	1267	1506	1691	
	<b>Max. input current</b>							
		Continuous (at 550 V) [A]	743	866	962	1079	1282	1440
		Continuous (at 575 V) [A]	711	828	920	1032	1227	1378
Continuous (at 690 V) [A]		711	828	920	1032	1227	1378	
Max. cable size, motor [mm <sup>2</sup> (AWG <sup>2</sup> )]		8x150 (8x300 mcm)			12x150 (12x300 mcm)			
Max. cable size, mains [mm <sup>2</sup> (AWG <sup>2</sup> )]		8x240 (8x500 mcm)			8x456 8x900 mcm			
Max. cable size, load-sharing [mm <sup>2</sup> (AWG <sup>2</sup> )]		4x120 (4x250 mcm)						
Max. cable size, brake [mm <sup>2</sup> (AWG <sup>2</sup> )]		4x185 (4x350 mcm)			6x185 (6x350 mcm)			
Max. external pre-fuses [A] <sup>1)</sup>		1600				2000	2500	
Est. power loss at rated max. load [W] <sup>4)</sup> , 600 V, F1 & F2		10771	12272	13835	15592	18281	20825	
Est. power loss at rated max. load [W] <sup>4)</sup> , 690 V, F1 & F2		11315	12903	14533	16375	19207	21857	
Max added losses of Circuit Breaker or Disconnect & Contactor, F3 & F4	427	532	615	665	863	1044		
Max Panel Options Losses	400							
Weight, enclosure IP21, IP 54 [kg]	1004/ 1299	1004/ 1299	1004/ 1299	1246/ 1541	1246/ 1541	1280/1575		
Weight, Rectifier Module [kg]	102	102	102	136	136	136		
Weight, Inverter Module [kg]	102	102	136	102	102	136		
Efficiency <sup>4)</sup>	0.98							
Output frequency	0-500 Hz							
Heatsink overtemp. trip	85 °C							
Power card amb. trip	68 °C							

1) For type of fuse see section *Fuses*.

2) American Wire Gauge.

3) Measured using 5 m screened motor cables at rated load and rated frequency.

4) The typical power loss is at nominal load conditions and expected to be within +/-15% (tolerance relates to variety in voltage and cable conditions). Values are based on a typical motor efficiency (eff2/eff3 border line). Motors with lower efficiency will also add to the power loss in the frequency converter and opposite. If the switching frequency is increased comed to the default setting, the power losses may rise sig-



nificantly.LCP and typical control card power consumptions are included. Further options and customer load may add up to 30W to the losses.  
(Though typical only 4W extra for a fully loaded control card, or options for slot A or slot B, each).  
Although measurements are made with state of the art equipment, some measurement inaccuracy must be allowed for (+/-5%).



8

## 8 Warnings and Alarms

### 8.1.1 Alarms and Warnings

A warning or an alarm is signalled by the relevant LED on the front of the frequency converter and indicated by a code on the display.

A warning remains active until its cause is no longer present. Under certain circumstances operation of the motor may still be continued. Warning messages may be critical, but are not necessarily so.

In the event of an alarm, the frequency converter will have tripped. Alarms must be reset to restart operation once their cause has been rectified.

**This may be done in four ways:**

1. By using the [RESET] control button on the LCP.
2. Via a digital input with the "Reset" function.
3. Via serial communication/optional fieldbus.
4. By resetting automatically using the [Auto Reset] function, which is a default setting for IVS 102 Drive, see par. 14-20 *Reset Mode* in the *IVS 102 Programming Guide*



**NB!**  
After a manual reset using the [RESET] button on the LCP, the [AUTO ON] or [HAND ON] button must be pressed to restart the motor.

If an alarm cannot be reset, the reason may be that its cause has not been rectified, or the alarm is trip-locked (see also table on following page).

Alarms that are trip-locked offer additional protection, means that the mains supply must be switched off before the alarm can be reset. After being switched back on, the frequency converter is no longer blocked and may be reset as described above once the cause has been rectified.

Alarms that are not trip-locked can also be reset using the automatic reset function in par. 14-20 *Reset Mode* (Warning: automatic wake-up is possible!)

If a warning and alarm is marked against a code in the table on the following page, this means that either a warning occurs before an alarm, or it can be specified whether it is a warning or an alarm that is to be displayed for a given fault.

This is possible, for instance, in par.1-90 *Motor Thermal Protection*. After an alarm or trip, the motor carries on coasting, and the alarm and warning flash on the frequency converter. Once the problem has been rectified, only the alarm continues flashing.

No.	Description	Warning	Alarm/Trip	Alarm/Trip Lock	Parameter Reference
1	10 Volts low	X			
2	Live zero error	(X)	(X)		6-01
3	No motor	(X)			1-80
4	Mains phase loss	(X)	(X)	(X)	14-12
5	DC link voltage high	X			
6	DC link voltage low	X			
7	DC over voltage	X	X		
8	DC under voltage	X	X		
9	Inverter overloaded	X	X		
10	Motor ETR over temperature	(X)	(X)		1-90
11	Motor thermistor over temperature	(X)	(X)		1-90
12	Torque limit	X	X		
13	Over Current	X	X	X	
14	Earth fault	X	X	X	
15	Hardware mismatch		X	X	
16	Short Circuit		X	X	
17	Control word timeout	(X)	(X)		8-04
23	Internal Fan Fault	X			
24	External Fan Fault	X			14-53
25	Brake resistor short-circuited	X			
26	Brake resistor power limit	(X)	(X)		2-13
27	Brake chopper short-circuited	X	X		
28	Brake check	(X)	(X)		2-15
29	Drive over temperature	X	X	X	
30	Motor phase U missing	(X)	(X)	(X)	4-58
31	Motor phase V missing	(X)	(X)	(X)	4-58
32	Motor phase W missing	(X)	(X)	(X)	4-58
33	Inrush fault		X	X	
34	Fieldbus communication fault	X	X		
35	Out of frequency range	X	X		
36	Mains failure	X	X		
37	Phase Imbalance	X	X		
38	Internal fault		X	X	
39	Heatsink sensor		X	X	
40	Overload of Digital Output Terminal 27	(X)			5-00, 5-01
41	Overload of Digital Output Terminal 29	(X)			5-00, 5-02
42	Overload of Digital Output On X30/6	(X)			5-32
42	Overload of Digital Output On X30/7	(X)			5-33
46	Pwr. card supply		X	X	
47	24 V supply low	X	X	X	
48	1.8 V supply low		X	X	
49	Speed limit	X	(X)		1-86
50	AMA calibration failed		X		
51	AMA check $U_{nom}$ and $I_{nom}$		X		
52	AMA low $I_{nom}$		X		
53	AMA motor too big		X		
54	AMA motor too small		X		
55	AMA Parameter out of range		X		
56	AMA interrupted by user		X		
57	AMA timeout		X		
58	AMA internal fault	X	X		
59	Current limit	X			
60	External Interlock	X			
62	Output Frequency at Maximum Limit	X			
64	Voltage Limit	X			
65	Control Board Over-temperature	X	X	X	

Table 8.1: Alarm/Warning code list

No.	Description	Warning	Alarm/Trip	Alarm/Trip Lock	Parameter Reference
66	Heat sink Temperature Low	X			
67	Option Configuration has Changed		X		
68	Safe Stop Activated		X <sup>1)</sup>		
69	Pwr. Card Temp		X	X	
70	Illegal FC configuration			X	
71	PTC 1 Safe Stop	X	X <sup>1)</sup>		
72	Dangerous Failure			X <sup>1)</sup>	
73	Safe Stop Auto Restart				
76	Power Unit Setup	X			
79	Illegal PS config		X	X	
80	Drive Initialised to Default Value		X		
91	Analog input 54 wrong settings			X	
92	NoFlow	X	X		22-2*
93	Dry Pump	X	X		22-2*
94	End of Curve	X	X		22-5*
95	Broken Belt	X	X		22-6*
96	Start Delayed	X			22-7*
97	Stop Delayed	X			22-7*
98	Clock Fault	X			0-7*
201	Fire M was Active				
202	Fire M Limits Exceeded				
203	Missing Motor				
204	Locked Rotor				
243	Brake IGBT	X	X		
244	Heatsink temp	X	X	X	
245	Heatsink sensor		X	X	
246	Pwr.card supply		X	X	
247	Pwr.card temp		X	X	
248	Illegal PS config		X	X	
250	New spare parts			X	
251	New Type Code		X	X	

Table 8.2: Alarm/Warning code list

(X) Dependent on parameter

1) Can not be Auto reset via par. 14-20 *Reset Mode*

A trip is the action when an alarm has appeared. The trip will coast the motor and can be reset by pressing the reset button or make a reset by a digital input (parameter group 5-1\* [1]). The original event that caused an alarm cannot damage the frequency converter or cause dangerous conditions. A trip lock is an action when an alarm occurs, which may cause damage to frequency converter or connected parts. A Trip Lock situation can only be reset by a power cycling.

<i>LED indication</i>	
Warning	yellow
Alarm	flashing red
Trip locked	yellow and red

Alarm Word and Extended Status Word					
Bit	Hex	Dec	Alarm Word	Warning Word	Extended Status Word
0	00000001	1	Brake Check	Brake Check	Ramping
1	00000002	2	Pwr. Card Temp	Pwr. Card Temp	AMA Running
2	00000004	4	Earth Fault	Earth Fault	Start CW/CCW
3	00000008	8	Ctrl.Card Temp	Ctrl.Card Temp	Slow Down
4	00000010	16	Ctrl. Word TO	Ctrl. Word TO	Catch Up
5	00000020	32	Over Current	Over Current	Feedback High
6	00000040	64	Torque Limit	Torque Limit	Feedback Low
7	00000080	128	Motor Th Over	Motor Th Over	Output Current High
8	00000100	256	Motor ETR Over	Motor ETR Over	Output Current Low
9	00000200	512	Inverter Overld.	Inverter Overld.	Output Freq High
10	00000400	1024	DC under Volt	DC under Volt	Output Freq Low
11	00000800	2048	DC over Volt	DC over Volt	Brake Check OK
12	00001000	4096	Short Circuit	DC Voltage Low	Braking Max
13	00002000	8192	Inrush Fault	DC Voltage High	Braking
14	00004000	16384	Mains ph. Loss	Mains ph. Loss	Out of Speed Range
15	00008000	32768	AMA Not OK	No Motor	OVC Active
16	00010000	65536	Live Zero Error	Live Zero Error	
17	00020000	131072	Internal Fault	10V Low	
18	00040000	262144	Brake Overload	Brake Overload	
19	00080000	524288	U phase Loss	Brake Resistor	
20	00100000	1048576	V phase Loss	Brake IGBT	
21	00200000	2097152	W phase Loss	Speed Limit	
22	00400000	4194304	Fieldbus Fault	Fieldbus Fault	
23	00800000	8388608	24 V Supply Low	24V Supply Low	
24	01000000	16777216	Mains Failure	Mains Failure	
25	02000000	33554432	1.8V Supply Low	Current Limit	
26	04000000	67108864	Brake Resistor	Low Temp	
27	08000000	134217728	Brake IGBT	Voltage Limit	
28	10000000	268435456	Option Change	Unused	
29	20000000	536870912	Drive Initialised	Unused	
30	40000000	1073741824	Safe Stop	Unused	

Table 8.3: Description of Alarm Word, Warning Word and Extended Status Word

The alarm words, warning words and extended status words can be read out via serial bus or optional fieldbus for diagnosis. See also par. 16-90 *Alarm Word*, par. 16-92 *Warning Word* and par. 16-94 *Ext. Status Word*.

### 8.1.2 Fault messages

**WARNING 1, 10 volts low**

The control card voltage is below 10 V from terminal 50. Remove some of the load from terminal 50, as the 10 V supply is overloaded. Max. 15 mA or minimum 590 Ω. This condition can be caused by a short in a connected potentiometer or improper wiring of the potentiometer.

**Troubleshooting:** Remove the wiring from terminal 50. If the warning clears, the problem is with the customer wiring. If the warning does not clear, replace the control card.

**WARNING/ALARM 2, Live zero error**

This warning or alarm will only appear if programmed by the user in par. 6-01 *Live Zero Timeout Function*. The signal on one of the analog inputs is less than 50% of the minimum value programmed for that input. This condition can be caused by broken wiring or faulty device sending the signal.

**WARNING/ALARM 3, No motor**

No motor has been connected to the output of the frequency converter. This warning or alarm will only appear if programmed by the user in par. 1-80 *Function at Stop*.

**Troubleshooting:** Check the connection between the drive and the motor.

**WARNING/ALARM 4, Mains phase loss**

A phase is missing on the supply side, or the mains voltage imbalance is too high. This message also appears for a fault in the input rectifier on the frequency converter. Options are programmed at par. 14-12 *Function at Mains Imbalance*.

**Troubleshooting:** Check the supply voltage and supply currents to the frequency converter.

**WARNING 5, DC link voltage high**

The intermediate circuit voltage (DC) is higher than the high voltage warning limit. The limit is dependent on the drive voltage rating. The frequency converter is still active.

**WARNING 6, DC link voltage low**

The intermediate circuit voltage (DC) is lower than the low voltage warning limit. The limit is dependent on the drive voltage rating. The frequency converter is still active.

**WARNING/ALARM 7, DC overvoltage**

If the intermediate circuit voltage exceeds the limit, the frequency converter trips after a time.

**Troubleshooting:**

- Connect a brake resistor
- Extend the ramp time
- Change the ramp type
- Activate functions in par. 2-10 *Brake Function*
- Increase par. 14-26 *Trip Delay at Inverter Fault*

**WARNING/ALARM 8, DC under voltage**

If the intermediate circuit voltage (DC) drops below the under voltage limit, the frequency converter checks if a 24 V backup supply is connected. If no 24 V backup supply is connected, the frequency converter trips after a fixed time delay. The time delay varies with unit size.

**WARNING/ALARM 9, Inverter overloaded**

The frequency converter is about to cut out because of an overload (too high current for too long). The counter for electronic, thermal inverter protection gives a warning at 98% and trips at 100%, while giving an alarm. The frequency converter *cannot* be reset until the counter is below 90%.

The fault is that the frequency converter is overloaded by more than 100% for too long. Note: See the derating section in the Design Guide for more details if a high switching frequency is required.

**WARNING/ALARM 10, Motor overload temperature**

According to the electronic thermal protection (ETR), the motor is too hot. Select whether the frequency converter gives a warning or an alarm when the counter reaches 100% in par. 1-90 *Motor Thermal Protection*. The fault is that the motor is overloaded by more than 100% for too long.

**Troubleshooting:**

- Check if motor is over heating.
- If the motor is mechanically overloaded
- That the motor par. 1-24 *Motor Current* is set correctly.
- Motor data in parameters 1-20 through 1-25 are set correctly.
- The setting in par. 1-91 *Motor External Fan*.
- Run AMA in par.1-29 *Automatic Motor Adaptation (AMA)*.

**WARNING/ALARM 11, Motor thermistor over temp**

The thermistor or the thermistor connection is disconnected. Select whether the frequency converter gives a warning or an alarm when the counter reaches 100% in par. 1-90 *Motor Thermal Protection*.

**Troubleshooting:**

- Check if motor is over heating.
- Check if the motor is mechanically overloaded.
- Check that the thermistor is connected correctly between terminal 53 or 54 (analog voltage input) and terminal 50 (+10 V supply), or between terminal 18 or 19 (digital input PNP only) and terminal 50.
- If a KTY sensor is used, check for correct connection between terminal 54 and 55.
- If using a thermal switch or thermistor, check the programming of par.1-93 *Thermistor Source* matches sensor wiring.
- If using a KTY sensor, check the programming of ameters 1-95, 1-96, and 1-97 match sensor wiring.

**WARNING/ALARM 12, Torque limit**

The torque is higher than the value in par. 4-16 *Torque Limit Motor Mode* (in motor operation) or the torque is higher than the value in par. 4-17 *Torque Limit Generator Mode* (in regenerative operation). Par. 14-25 *Trip Delay at Torque Limit* can be used to change this from a warning only condition to a warning followed by an alarm.

**WARNING/ALARM 13, Over Current**

The inverter peak current limit (approx. 200% of the rated current) is exceeded. The warning lasts about 1.5 sec., then the frequency converter trips and issues an alarm. If extended mechanical brake control is selected, trip can be reset externally.



**Troubleshooting:**

This fault may be caused by shock loading or fast acceleration with high inertia loads.

Turn off the frequency converter. Check if the motor shaft can be turned.

Check that the motor size matches the frequency converter.

Incorrect motor data in parameters 1-20 through 1-25.

**ALARM 14, Earth (ground) fault**

There is a discharge from the output phases to earth, either in the cable between the frequency converter and the motor or in the motor itself.

**Troubleshooting:**

Turn off the frequency converter and remove the earth fault.

Measure the resistance to ground of the motor leads and the motor with a megohmmeter to check for earth faults in the motor.

Perform current sensor test.

**ALARM 15, Hardware mismatch**

A fitted option is not operational with the present control board hardware or software.

Record the value of the following parameters and contact your Armstrong supplier:

Par. 15-40 *FC Type*

Par. 15-41 *Power Section*

Par. 15-42 *Voltage*

Par. 15-43 *Software Version*

Par. 15-45 *Actual Typecode String*

Par. 15-49 *SW ID Control Card*

Par. 15-50 *SW ID Power Card*

Par. 15-60 *Option Mounted*

Par. 15-61 *Option SW Version*

**ALARM 16, Short circuit**

There is short-circuiting in the motor or on the motor terminals.

Turn off the frequency converter and remove the short-circuit.

**WARNING/ALARM 17, Control word timeout**

There is no communication to the frequency converter.

The warning will only be active when par. 8-04 *Control Word Timeout Function* is NOT set to OFF.

If par. 8-04 *Control Word Timeout Function* is set to *Stop* and *Trip*, a warning appears and the frequency converter ramps down until it trips, while giving an alarm.

**Troubleshooting:**

Check connections on the serial communication cable.

Increase par. 8-03 *Control Word Timeout Time*

Check operation of the communication equipment.

Verify proper installation based on EMC requirements.

**WARNING 23, Internal fan fault**

The fan warning function is an extra protection function that checks if the fan is running / mounted. The fan warning can be disabled in par. 14-53 *Fan Monitor* ([0] Disabled).

For the D, E, and F Frame drives, the regulated voltage to the fans is monitored.

**Troubleshooting:**

Check fan resistance.

Check soft charge fuses.

**WARNING 24, External fan fault**

The fan warning function is an extra protection function that checks if the fan is running / mounted. The fan warning can be disabled in par. 14-53 *Fan Monitor* ([0] Disabled).

For the D, E, and F Frame drives, the regulated voltage to the fans is monitored.

**Troubleshooting:**

Check fan resistance.

Check soft charge fuses.

**WARNING 25, Brake resistor short circuit**

The brake resistor is monitored during operation. If it short circuits, the brake function is disconnected and the warning appears. The frequency converter still works, but without the brake function. Turn off the frequency converter and replace the brake resistor (see par. 2-15 *Brake Check*).

**WARNING/ALARM 26, Brake resistor power limit**

The power transmitted to the brake resistor is calculated: as a percentage, as a mean value over the last 120 seconds, on the basis of the resistance value of the brake resistor, and the intermediate circuit voltage. The warning is active when the dissipated braking power is higher than 90%. If *Trip [2]* has been selected in par. 2-13 *Brake Power Monitoring*, the frequency converter cuts out and issues this alarm, when the dissipated braking power is higher than 100%.

**WARNING/ALARM 27, Brake chopper fault**

The brake transistor is monitored during operation and if it short-circuits, the brake function disconnects and issues a warning. The frequency converter is still able to run, but since the brake transistor has short-circuited, substantial power is transmitted to the brake resistor, even if it is inactive. Turn off the frequency converter and remove the brake resistor.

This alarm/ warning could also occur should the brake resistor overheat. Terminal 104 to 106 are available as brake resistor. Klixon inputs, see section Brake Resistor Temperature Switch.

**WARNING/ALARM 28, Brake check failed**

Brake resistor fault: the brake resistor is not connected or not working. Check par. 2-15 *Brake Check*.

**ALARM 29, Heatsink temp**

The maximum temperature of the heatsink has been exceeded. The temperature fault will not be reset until the temperature falls below a defined heatsink temperature. The trip and reset point are different based on the drive power size.

**Troubleshooting:**

Ambient temperature too high.

Too long motor cable.

Incorrect clearance above and below the drive.

Dirty heatsink.

Blocked air flow around the drive.

Damaged heatsink fan.

For the D, E, and F Frame Drives, this alarm is based on the temperature measured by the heatsink sensor mounted inside the IGBT modules. For



the F Frame drives, this alarm can also be caused by the thermal sensor in the Rectifier module.

**Troubleshooting:**

- Check fan resistance.
- Check soft charge fuses.
- IGBT thermal sensor.

**ALARM 30, Motor phase U missing**

Motor phase U between the frequency converter and the motor is missing.

Turn off the frequency converter and check motor phase U.

**ALARM 31, Motor phase V missing**

Motor phase V between the frequency converter and the motor is missing. Turn off the frequency converter and check motor phase V.

**ALARM 32, Motor phase W missing**

Motor phase W between the frequency converter and the motor is missing.

Turn off the frequency converter and check motor phase W.

**ALARM 33, Inrush fault**

Too many power-ups have occurred within a short time period. Let unit cool to operating temperature.

**WARNING/ALARM 34, Fieldbus communication fault**

The fieldbus on the communication option card is not working.

**WARNING/ALARM 35, Out of frequency range:**

This warning is active if the output frequency has reached the high limit (set in par. 4-53) or low limit (set in par. 4-52). In *Process Control, Closed Loop* (. 1-00) this warning is displayed.

**WARNING/ALARM 36, Mains failure**

This warning/alarm is only active if the supply voltage to the frequency converter is lost and par. 14-10 *Mains Failure* is NOT set to OFF. Check the fuses to the frequency converter

**ALARM 38, Internal fault**

It may be necessary to contact your Armstrong supplier. Some typical alarm messages:

0	Serial port cannot be initialized. Serious hardware failure
256-258	Power EEPROM data is defect or too old
512	Control board EEPROM data is defect or too old
513	Communication time out reading EEPROM data
514	Communication time out reading EEPROM data

515	Application Orientated Control cannot recognize the EEPROM data
516	Cannot write to the EEPROM because a write command is on progress
517	Write command is under time out
518	Failure in the EEPROM
519	Missing or invalid Barcode data in EEPROM
783	Parameter value outside of min/max limits
1024-1279	A can-telegram that has to be sent, couldn't be sent
1281	Digital Signal Processor flash timeout
1282	Power micro software version mismatch
1283	Power EEPROM data version mismatch
1284	Cannot read Digital Signal Processor software version
1299	Option SW in slot A is too old
1300	Option SW in slot B is too old
1301	Option SW in slot C0 is too old
1302	Option SW in slot C1 is too old
1315	Option SW in slot A is not supported (not allowed)
1316	Option SW in slot B is not supported (not allowed)
1317	Option SW in slot C0 is not supported (not allowed)
1318	Option SW in slot C1 is not supported (not allowed)
1379	Option A did not respond when calculating Platform Version.
1380	Option B did not respond when calculating Platform Version.
1381	Option C0 did not respond when calculating Platform Version.
1382	Option C1 did not respond when calculating Platform Version.
1536	An exception in the Application Orientated Control is registered. Debug information written in LCP
1792	DSP watchdog is active. Debugging of power t data Motor Orientated Control data not transferred correctly
2049	Power data restarted
2064-2072	H081x: option in slot x has restarted
2080-2088	H082x: option in slot x has issued a powerup-wait
2096-2104	H083x: option in slot x has issued a legal powerup-wait
2304	Could not read any data from power EEPROM
2305	Missing SW version from power unit
2314	Missing power unit data from power unit
2315	Missing SW version from power unit
2316	Missing io_statepage from power unit
2324	Power card configuration is determined to be incorrect at power up
2330	Power size information between the power cards does not match
2561	No communication from DSP to ATACD
2562	No communication from ATACD to DSP (state running)
2816	Stack overflow Control board module
2817	Scheduler slow tasks
2818	Fast tasks
2819	Parameter thread
2820	LCP Stack overflow
2821	Serial port overflow
2822	USB port overflow
2836	cfListMempool too small
3072-5122	Parameter value is outside its limits
5123	Option in slot A: Hardware incompatible with Control board hardware
5124	Option in slot B: Hardware incompatible with Control board hardware
5125	Option in slot C0: Hardware incompatible with Control board hardware
5126	Option in slot C1: Hardware incompatible with Control board hardware
5376-6231	Out of memory



**ALARM 39, Heatsink sensor**

No feedback from the heatsink temperature sensor.

The signal from the IGBT thermal sensor is not available on the power card. The problem could be on the power card, on the gate drive card, or the ribbon cable between the power card and gate drive card.

**WARNING 40, Overload of Digital Output Terminal 27**

Check the load connected to terminal 27 or remove short-circuit connection. Check par. 5-00 *Digital I/O Mode* and par. 5-01 *Terminal 27 Mode*.

**WARNING 41, Overload of Digital Output Terminal 29**

Check the load connected to terminal 29 or remove short-circuit connection. Check par. 5-00 *Digital I/O Mode* and par. 5-02 *Terminal 29 Mode*.

**WARNING 42, Overload of Digital Output on X30/6 or Overload of Digital Output on X30/7**

For X30/6, check the load connected to X30/6 or remove short-circuit connection. Check par. 5-32 *Term X30/6 Digi Out (MCB 101)*.

For X30/7, check the load connected to X30/7 or remove short-circuit connection. Check par. 5-33 *Term X30/7 Digi Out (MCB 101)*.

**ALARM 46, Power card supply**

The supply on the power card is out of range.

There are three power supplies generated by the switch mode power supply (SMPS) on the power card: 24 V, 5V, +/- 18V. When powered with 24 VDC with the MCB 107 option, only the 24 V and 5 V supplies are monitored. When powered with three phase mains voltage, all three supplied are monitored.

**WARNING 47, 24 V supply low**

The 24 V DC is measured on the control card. The external V DC backup power supply may be overloaded, otherwise contact your Armstrong supplier.

**WARNING 48, 1.8 V supply low**

The 1.8 V DC supply used on the control card is outside of allowable limits. The power supply is measured on the control card.

**WARNING 49, Speed limit**

When the speed is not within the specified range in par. 4-11 and par. 4-13. the drive will show a warning. When the speed is below the specified limit in par. 1-86 *Trip Speed Low [RPM]* (except when starting or stopping) the drive will trip.

**ALARM 50, AMA calibration failed**

Contact your Armstrong supplier.

**ALARM 51, AMA check Unom and Inom**

The setting of motor voltage, motor current, and motor power is presumably wrong. Check the settings.

**ALARM 52, AMA low Inom**

The motor current is too low. Check the settings.

**ALARM 53, AMA motor too big**

The motor is too big for the AMA to be carried out.

**ALARM 54, AMA motor too small**

The motor is too big for the AMA to be carried out.

**ALARM 55, AMA Parameter out of range**

The parameter values found from the motor are outside acceptable range.

**ALARM 56, AMA interrupted by user**

The AMA has been interrupted by the user.

**ALARM 57, AMA timeout**

Try to start the AMA again a number of times, until the AMA is carried out. Please note that repeated runs may heat the motor to a level where the resistance  $R_s$  and  $R_r$  are increased. In most cases, however, this is not critical.

**ALARM 58, AMA internal fault**

Contact your Armstrong supplier.

**WARNING 59, Current limit**

The current is higher than the value in par. 4-18 *Current Limit*.

**WARNING 60, External interlock**

External interlock has been activated. To resume normal operation, apply 24 V DC to the terminal programmed for external interlock and reset the frequency converter (via serial communication, digital I/O, or by pressing reset button on keypad).

**WARNING 61, Tracking error**

An error has been detected between calculated motor speed and speed measurement from feedback device. The function for Warning/Alarm/Disable is set in 4-30, *Motor Feedback Loss Function*, error setting in 4-31, *Motor Feedback Speed Error*, and the allowed error time in 4-32, *Motor Feedback Loss Timeout*. During a commissioning procedure the function may be effective.

**WARNING 62, Output frequency at maximum limit**

The output frequency is higher than the value set in par. 4-19 *Max Output Frequency*

**WARNING 64, Voltage limit**

The load and speed combination demands a motor voltage higher than the actual DC link voltage.

**WARNING/ALARM/TRIP 65, Control card over temperature**

Control card over temperature: The cutout temperature of the control card is 80° C.

**WARNING 66, Heatsink temperature low**

This warning is based on the temperature sensor in the IGBT module.

**Troubleshooting:****ALARM 67, Option module configuration has changed**

One or more options have either been added or removed since the last power-down.

**ALARM 68, Safe stop activated**

Safe stop has been activated. To resume normal operation, apply 24 V DC to terminal 37, then send a reset signal (via Bus, Digital I/O, or by pressing the reset key. See par. .

**ALARM 69, Power card temperature**

The temperature sensor on the power card is either too hot or too cold.

**Troubleshooting:**

Check the operation of the door fans.

Check that the filters for the door fans are not blocked.

Check that the gland plate is properly installed on IP 21 and IP 54 (NEMA 1 and NEMA 12) drives.

**ALARM 70, Illegal FC Configuration**

Actual combination of control board and power board is illegal.

**WARNING/ALARM 71, PTC 1 safe stop**

Safe Stop has been activated from the MCB 112 PTC Thermistor Card (motor too warm). Normal operation can be resumed when the MCB 112 applies 24 V DC to T-37 again (when the motor temperature reaches an acceptable level) and when the Digital Input from the MCB 112 is deactivated. When that happens, a reset signal must be sent (via serial communication, digital I/O, or by pressing reset button on keypad). Note that if automatic restart is enabled, the motor may start when the fault is cleared.

**ALARM 72, Dangerous failure**

Safe stop with trip lock. Unexpected signal levels on safe stop and digital input from the MCB 112 PTC thermistor card.

**Warning 76, Power Unit Setup**

The required number of power units does not match the detected number of active power units.

**Troubleshooting:**

**Warning 73, Safe stop auto restart**

Safe stopped. Note that with automatic restart enabled, the motor may start when the fault is cleared.

**WARNING 77, Reduced power mode:**

This warning indicates that the drive is operating in reduced power mode (i.e. less than the allowed number of inverter sections). This warning will be generated on power cycle when the drive is set to run with fewer inverters and will remain on.

**ALARM 79, Illegal power section configuration**

The scaling card is the incorrect t number or not installed. Also MK102 connector on the power card could not be installed.

**ALARM 80, Drive initialized to default value**

Parameter settings are initialized to default settings after a manual reset.

**ALARM 91, Analog input 54 wrong settings**

Switch S202 has to be set in position OFF (voltage input) when a KTY sensor is connected to analog input terminal 54.

**ALARM 92, No flow**

A no-load situation has been detected in the system. See parameter group 22-2.

**ALARM 93, Dry pump**

A no-flow situation and high speed indicates that the pump has run dry. See parameter group 22-2.

**ALARM 94, End of curve**

Feedback stays lower than the set point which may indicate leakage in the pipe system. See parameter group 22-5.

**ALARM 95, Broken belt**

Torque is below the torque level set for no load, indicating a broken belt. See parameter group 22-6.

**ALARM 96, Start delayed**

Motor start has been delayed due to short-cycle protection active. See parameter group 22-7.

**WARNING 97, Stop delayed**

Stopping the motor has been delayed due to short cycle protection is active. See parameter group 22-7.

**WARNING 98, Clock fault**

Clock Fault. Time is not set or RTC clock (if mounted) has failed. See parameter group 0-7.

**WARNING 201, Fire M was Active**

Fire Mode has been active.

**WARNING 202, Fire M Limits Exceeded**

Fire Mode has suppressed one or more warranty voiding alarms.

**WARNING 203, Missing Motor**

A multi-motor under-load situation was detected, this could be due to e.g. a missing motor.

**WARNING 204, Locked Rotor**

A multi-motor overload situation was detected, this could be due to e.g. a locked rotor.

**ALARM 243, Brake IGBT**

This alarm is only for F Frame drives. It is equivalent to Alarm 27. The report value in the alarm log indicates which power module generated the alarm:

- 1 = left most inverter module.
- 2 = middle inverter module in F2 or F4 drive.
- 2 = right inverter module in F1 or F3 drive.
- 3 = right inverter module in F2 or F4 drive.
- 5 = rectifier module.

**ALARM 244, Heatsink temperature**

This alarm is only for F Frame drives. It is equivalent to Alarm 29. The report value in the alarm log indicates which power module generated the alarm:

- 1 = left most inverter module.
- 2 = middle inverter module in F2 or F4 drive.
- 2 = right inverter module in F1 or F3 drive.
- 3 = right inverter module in F2 or F4 drive.
- 5 = rectifier module.

**ALARM 245, Heatsink sensor**

This alarm is only for F Frame drives. It is equivalent to Alarm 39. The report value in the alarm log indicates which power module generated the alarm:

- 1 = left most inverter module.
- 2 = middle inverter module in F2 or F4 drive.
- 2 = right inverter module in F1 or F3 drive.
- 3 = right inverter module in F2 or F4 drive.
- 5 = rectifier module.

**ALARM 246, Power card supply**

This alarm is only for F Frame drives. It is equivalent to Alarm 46. The report value in the alarm log indicates which power module generated the alarm:

- 1 = left most inverter module.
- 2 = middle inverter module in F2 or F4 drive.
- 2 = right inverter module in F1 or F3 drive.
- 3 = right inverter module in F2 or F4 drive.
- 5 = rectifier module.

**ALARM 247, Power card temperature**

This alarm is only for F Frame drives. It is equivalent to Alarm 69. The report value in the alarm log indicates which power module generated the alarm:

- 1 = left most inverter module.
- 2 = middle inverter module in F2 or F4 drive.
- 2 = right inverter module in F1 or F3 drive.
- 3 = right inverter module in F2 or F4 drive.
- 5 = rectifier module.

**ALARM 248, Illegal power section configuration**

This alarm is only for F Frame drives. It is equivalent to Alarm 79. The report value in the alarm log indicates which power module generated the alarm:

- 1 = left most inverter module.
- 2 = middle inverter module in F2 or F4 drive.
- 2 = right inverter module in F1 or F3 drive.
- 3 = right inverter module in F2 or F4 drive.
- 5 = rectifier module.

**ALARM 250, New spare part**

The power or switch mode power supply has been exchanged. The frequency converter type code must be restored in the EEPROM. Select the correct type code in par. 14-23 *Typocode Setting* according to the label on the unit. Remember to select 'Save to EEPROM' to complete.

**ALARM 251, New type code**

The frequency converter has a new type code.

## Index

### 2

24 Vdc Power Supply .....	49
---------------------------	----

### 3

30 Ampere, Fuse-protected Terminals .....	49
---	----

## A

Abbreviations And Standards .....	7
Access To Control Terminals .....	72
Airflow .....	38
Alarm/warning Code List .....	172
Alarms And Warnings .....	171
Ama .....	79, 90
Analog Inputs .....	158
Analog Output .....	158
Auto Energy Optimization Compressor .....	105
Auto Energy Optimization Vt .....	105
Automatic Motor Adaptation (ama) .....	79, 105

## B

Back Cooling .....	37
Brake Cable .....	63
Brake Control .....	175
Brake Function 2-10 .....	108
Brake Resistor Temperature Switch .....	64
Broken Belt Delay 22-62 .....	127
Broken Belt Function 22-60 .....	127
Broken Belt Torque 22-61 .....	127

## C

Cable Lengths And Cross Sections .....	157
Cable Positions .....	30
Cable-length And Cross-section: .....	51
Cabling .....	51
Changes Made .....	95
Changing A Group Of Numeric Data Values .....	129
Changing A Text Value .....	129
Changing Data .....	129
Changing Of Data Value .....	130
Changing Parameter Data .....	95
Coast Inverse .....	97
Coasting .....	87
Communication Option .....	177
Configuration Mode 1-00 .....	104
Control Cables .....	77
Control Cables .....	76
Control Card Performance .....	160
Control Card, 10 V Dc Output .....	159
Control Card, 24 V Dc Output .....	159
Control Card, Rs-485 Serial Communication: .....	158
Control Card, Usb Serial Communication .....	160
Control Characteristics .....	159
Control Terminals .....	72
Cooling .....	106
Cooling .....	37
Copyright, Limitation Of Liability And Revision Rights .....	5

## D

Dc Hold/preheat Current 2-00 .....	108
Dc Link .....	175
Default Settings .....	91

Digital Inputs:	157
Digital Output	159
Disposal Instruction	13
Drip Shield Installation	43
Drives With Factory Installed Brake Chopper Option	63
Dry Pump Function 22-26	126
Duct Cooling	37
Duct Work Cooling Kits	44

## E

Earth Leakage Current	9
Earthing	61
Elcb Relays	61
Electrical Installation	72, 76
Electrical Ratings	10
Electronic Waste	13
Example Of Changing Parameter Data	95
External Fan Supply	65
External Temperature Monitoring	49

## F

Fault Messages	175
Feedback 1 Conversion 20-01	121
Feedback 1 Source 20-00	120
Feedback 2 Conversion 20-04	121
Feedback 2 Source 20-03	121
Feedback 3 Conversion 20-07	122
Feedback Function 20-20	122
Fieldbus Connection	71
Floor Mounting	46
Flying Start 1-73	106
Frame Size F Panel Options	1
Function At Stop 1-80	106
Function Relay 5-40	113
Function Setups	101
Fuse Tables	66
Fuses	66
Fusing	51

## G

General Considerations	27
General Warning.	6
Gland/conduit Entry - Ip21 (nema 1) And Ip54 (nema12)	41
GlcP	90
Graphical Display	83

## H

High-voltage Warning	6
How To Connect A Pc To The Frequency Converter	88
How To Operate Graphical (glcp)	83

## I

Iec Emergency Stop With Pilz Safety Relay	48
Indexed Parameters	130
Indicator Lights (leds)	85
Initialisation	91
Input Polarity Of Control Terminals	77
Installation At High Altitudes (pelv)	11
Installation Of 24 Volt External Dc Supply	72
Installation Of Duct Cooling Kit In Rittal	44
Installation Of Input Plate Options	47
Installation Of Mains Shield For Frequency Converters	47
Installation On Pedestal	46
Installation On The Wall - Ip21 (nema 1) And Ip54 (nema 12) Units	40

Insulation Resistance Monitor (irm)	48
Interval Between Starts 22-76	127
It Mains	61

## J

[Jog Speed Hz] 3-11	101
---------------------	-----

## K

Kty Sensor	175
------------	-----

## L

Language 0-01	98
Language Package 1	98
Language Package 2	98
Language Package 3	98
Language Package 4	98
Lcp 102	83
Leakage Current	9
Leds	83
Lifting	17
Literature	6
Live Zero Timeout Function 6-01	115
Live Zero Timeout Time 6-00	115
Load Sharing	64
Loggings	95
Low Power Detection 22-21	125
Low Speed Detection 22-22	125

## M

Main Menu	95
Main Menu Mode	86, 128
Main Menu Structure	130
Main Reactance	105
Mains Connection	65
Mains Supply (I1, L2, L3):	157
Mains Supply 3 X 525- 690 Vac	164
Manual Motor Starters	49
Maximum Reference 3-03	108
Mct 10	89
Mechanical Brake Control	81
Mechanical Dimensions	25
Mechanical Dimensions	19
Mechanical Installation	27
Minimum Reference 3-02	108
Minimum Run Time 22-40	126, 127
Minimum Sleep Time 22-41	126
Motor Cable	62
Motor Current 1-24	99
Motor Frequency 1-23	99
Motor Name Plate	79
Motor Nominal Speed 1-25	99
Motor Output	157
[Motor Power Hp] 1-21	99
[Motor Power Kw] 1-20	98
Motor Protection	106, 160
Motor Rotation Check 1-28	100
Motor Speed Direction 4-10	110
[Motor Speed High Limit Hz] 4-14	100
[Motor Speed High Limit Rpm] 4-13	100
[Motor Speed Low Limit Hz] 4-12	100
[Motor Speed Low Limit Rpm] 4-11	101
Motor Thermal Protection	81, 106
Motor Voltage 1-22	99
My Personal Menu	95

**N**

Name Plate Data	79
Namur	48
No Operation	97
No-flow Delay 22-24	126
No-flow Function 22-23	125
Non UI Compliance	66

**O**

Ordering	45
Output Performance (u, V, W)	157
Outside Installation/ Nema 3r Kit For Rittal	45
Over-voltage Control 2-17	108

**P**

Parallel Connection Of Motors	81
Parameter Data	95
Parameter Selection	128
Parameter Set-up	93
Pc Software Tools	89
Pedestal Installation	46
Pid Integral Time 20-94	125
Pid Normal/ Inverse Control 20-81	124
Pid Proportional Gain 20-93	125
Planning The Installation Site	15
Potentiometer Reference	75
Power Connections	51
Preset Reference 3-10	109
Profibus Dp-v1	89
Protection	66
Protection And Features	160
Pulse Inputs	158
Pulse Start/stop	74

**Q**

Quick Menu	86, 95
Quick Menu Mode	86, 95
Quick Transfer Of Parameter Settings When Using Glcp	90

**R**

Ramp 1 Ramp Down Time 3-42	100
Ramp 1 Ramp Up Time 3-41	100
Rcd (residual Current Device)	48
Receiving The Frequency Converter	16
Reference 1 Source 3-15	109
Reference 2 Source 3-16	109
Relay Outputs	159
Residual Current Device	9
Rfi Switch	61
Rs-485 Bus Connection	88

**S**

Screened/armoured	77
Screening Of Cables:	51
Semi-auto Bypass Set-up 4-64	111
Serial Communication	160
Setpoint 1 20-21	124
Setpoint 2 20-22	124
Shielded Cables	62
Short Cycle Protection 22-75	127
Sine-wave Filter	52
Space	27



Space Heaters And Thermostat .....	48
Speed Up/down .....	75
Start Delay 1-71 .....	106
Start/stop .....	74
Stator Leakage Reactance .....	105
Status .....	86
Status Messages .....	83
Step-by-step .....	130
Surroundings .....	159
Switches S201, S202, And S801 .....	78
Switching Frequency 14-01 .....	120
Switching Frequency: .....	51

## T

Terminal 27 Mode 5-01 .....	111
Terminal 29 Mode 5-02 .....	111
Terminal 42 Output 6-50 .....	117
Terminal 42 Output Max Scale 6-52 .....	118
Terminal 42 Output Min Scale 6-51 .....	118
Terminal 53 Filter Time Constant 6-16 .....	116
Terminal 53 High Ref./feedb. Value 6-15 .....	116
Terminal 53 High Voltage 6-11 .....	116
Terminal 53 Live Zero 6-17 .....	116
Terminal 53 Low Ref./feedb. Value 6-14 .....	116
Terminal 53 Low Voltage 6-10 .....	116
Terminal 54 Filter Time Constant 6-26 .....	117
Terminal 54 High Ref./feedb. Value 6-25 .....	117
Terminal 54 High Voltage 6-21 .....	116
Terminal 54 Live Zero 6-27 .....	117
Terminal 54 Low Ref./feedb. Value 6-24 .....	116
Terminal 54 Low Voltage 6-20 .....	116
Terminal Locations .....	31
Terminal Locations - Frame Size D .....	1
Thermistor .....	107
Thermistor Source 1-93 .....	107
Three Ways Of Operating .....	83
Torque .....	62
Torque Characteristics 1-03 .....	105, 157
Torque For Terminals .....	62

## U

Unpacking .....	16
-----------------	----

## V

Voltage Level .....	157
Voltage Reference Via A Potentiometer .....	75

## W

[Wake-up Speed Rpm] 22-42 .....	127
Warning Feedback High 4-57 .....	110
Warning Feedback Low 4-56 .....	110
Warning Speed High 4-53 .....	110
Wire Access .....	28